

GENEL / PUBLIC  
**Genel /  
Public**

# **CITIPORT**

## **USER MANUAL**

**ANADOLU ISUZU**

Revision No:02

**Genel /  
Public**

GENEL / PUBLIC  
**Genel /  
Public**



It is a symbolic photograph of Citiport vehicle.

**Genel /  
Public**

## INTRODUCTION

This User Manual is prepared to give general information about the efficient and most economical use of E6 Citiport 18 vehicle.

We strongly encourage you to review the User Manual so you will have a better understanding of your vehicle's capabilities and limitations. Please follow the instructions and read warning notices carefully in the User Manual. Disregarding them may lead damage to the vehicle or personal injury. Vehicle damage results from the disregard of the instructions or restrictions is not covered by Anadolu Isuzu.

All information in the User Manual is current at the time of printing. Anadolu Isuzu reserves to make changes at any time without notice as a result of continual product improvement.

Keep the User Manual in the vehicle at all times. If you sell or rent the vehicle, always pass the User Manual on to the new owner or new user.

For further information about the vehicle, apply the authorized dealers and authorized services that are listed in the User Manual.

This User Manual cannot be reprinted, translated or reproduced, in whole or in part in any form or format, without written permission of Anadolu Isuzu.

Thank you for choosing an Anadolu Isuzu vehicle.

### **Anadolu Isuzu Automotive Industry and Trade Inc.**

**Headquarters:** Fatih Sultan Mehmet Mah. Balkan Cad. No: 58 Buyaka E Blok

Tepeüstü 34771 Ümraniye / İSTANBUL

**Factory** : Şekerpınar Mah. Otomotiv Cad. No: 2 41435 Çayırova / KOCAELİ

**Telephone** 0850 200 1900

**e – mail** : [isuzu@isuzu.com.tr](mailto:isuzu@isuzu.com.tr)



It is a symbolic photograph of Citiport vehicle.

## TABLE OF CONTENTS

<b>VEHICLE INFORMATION</b>	<b>1</b>
About Warranty	1
Vehicle Identification Number (VIN) and Engine Number	1
<b>IMPORTANT INFORMATION</b>	<b>3</b>
Before Driving	3
Driving	7
Stopping and Parking	11
Diesel Particulate Filter (DPF)	13
Urea Selective Catalytic Reduction (SCR)	15
Automatic Greasing System	16
Engine Room Fire Detection System	16
Vehicle Data Collection	16
<b>EQUIPMENT AND ACCESSORIES</b>	<b>18</b>
Opening and Closing Doors	18
Wheelchair Ramp	19
Seats	19
Mirrors	28
Roller Blind	28
Side Window With Resistance	28
Water Heater / Cooler For Driver (Optional)	28
Camera System	29
Money Box	29
Tachograph	29
Preheater	30
Destination Indicator	64
Destination Indicator (Hanover-Optional)	64
Amplifier	64
Radio	65
Engine Compartment Fire Detection And Automatic Fire Suppression System (Firedect - Optional - 1)	67
Engine Room Fire Extinguishing System (Lehavot – Optional-2)	74
Engine Room Fire Extinguishing System (Fogmaker – Optional-3)	79
Trapdoor	76
Handless	76
Stop Button	76
Thermoelectric Refrigerator	77
<b>CONTROLS AND INSTRUMENTS</b>	<b>80</b>
Starting and Stopping the Engine	80
Instruments, Warning Lights and Indicator Lights	81
Switches	90
Driving Controls	100

## IV | TABLE OF CONTENTS

---

<b>COMFORT AND CONVENIENCE</b>	<b>109</b>
Automatic Air Conditioner	109
Air Conditioner Control Unit (Konvekta-Optional)	111
<b>TIPS ON SAFE DRIVING</b>	<b>118</b>
Driving Safely	118
On The Road	118
Cautions for Driving In Hot Regions	123
Cautions for Driving In Cold Regions	123
<b>SERVICE AND MAINTENANCE</b>	<b>126</b>
Before Service and Maintenance	126
Daily Checks	128
Engine-Related Service and Maintenance	129
Chassis-Related Service and Maintenance	137
Other Service and Maintenance	144
Interior and Exterior Maintenance	149
Maintenance Data	153
<b>IN CASE OF EMERGENCY</b>	<b>157</b>
Troubleshooting	157
When the Vehicle Breaks Down During Driving	157
When the Tire Goes Flat	157
When the Engine Stops While Driving	157
When the Engine Stalls and Cannot Be Restarted	158
When the Brakes Do Not Work	158
When the Battery Goes Flat	158
When the Fuel Runs Out	159
When the Warning Light Comes On	159
When the Engine Overheats	162
When the Bulb Does Not Come On	162
When Your Vehicle Is Involved In an Accident	163
When Driving On Bad Roads	163
When Towing	164
<b>MAIN DATA</b>	<b>165</b>
Main Data and Specifications	165
Fluid Specifications	166
Pressure Values	166
<b>SERVICE NETWORK</b>	<b>167</b>

## VEHICLE INFORMATION

### ABOUT WARRANTY

In the unlikely event that a failure occurs as a result of manufacturing liability, the vehicle will be repaired free of charge within the scope described in the warranty, so please read the warranty and contact your local sales company.

Anadolu Isuzu cannot guarantee the failure or accident that occurred due to carelessness in handling or failure to perform maintenance described in the maintenance note.

Please refer to Service Network for the location of the sales company.

### VEHICLE IDENTIFICATION NUMBER (VIN) AND ENGINE NUMBER

The VIN and engine number are necessary for registering your vehicle. They are also necessary when your vehicle undergoes official inspections. Provide your Isuzu Dealer with these numbers when you are having the vehicle repaired or are ordering replacement parts. The Dealer will be able to do the requested jobs more competently and quickly.

### VEHICLE IDENTIFICATION NUMBER (VIN)

#### VIN Location

The VIN is stamped on under the right-side front seat.

#### ADVICE

- The location of the ID plate may differ depending on the market. For further details, ask your Isuzu Dealer.

#### ID Plate



The ID plate indicates type approval number, VIN, the sum of the maximum axle load, maximum front axle load and the maximum rear axle load. This single number contains multiple pieces of information including the vehicle and engine model codes as shown below.

## 2 | VEHICLE INFORMATION

BUS VIN DESCRIPTION																
1	2	3	4	5	6	7	8	9	10	11	12	13	14	15	16	17
N	N	A	B	1	8	D	A	0	S	A	0	0	0	0	0	1
<small>(SAMPLE)</small>																
1-3	INTERNATIONAL WMI NO:						NNA	(AIOS) ANADOLU ISUZU OTOMOTIV SANAYI VE TICARET ANONIM SIRKETI								
4	MODEL LINE						S	INTERCITY / INTERURBAN BUS GROUP								
							B	CITY / URBAN BUS GROUP								
							L	RESERVED								
							T	Q-BUS31 / TURKUAZ								
5-6	VEHICLE LENGTH						80	VEHICLES WHICH ITS LENGTH DEFINED BETWEEN 7,5m AND 8,5m (NOVO / NOVOCITI (S801), NOVOCITI LIFE / VOLT (B801), TURKUAZ (Q-BUS31))								
							85	VEHICLES WHICH ITS LENGTH DEFINED BETWEEN 7,5m AND 8,5m (GRAND TORO (S802))								
							90	VEHICLES WHICH ITS LENGTH DEFINED BETWEEN 8,51m AND 10m (CITIBUS (B902), VISIGO (S902))								
							12	VEHICLES WHICH ITS LENGTH DEFINED AS 12m (CITIPOINT (B120), CITIVOLT (B120))								
							13	VEHICLES WHICH ITS LENGTH DEFINED AS 13m (KENDO DIESEL (S130), KENDO CNG (S130))								
							18	VEHICLES WHICH ITS LENGTH DEFINED AS 18m (CITIPOINT 18M (B180), CITIVOLT 18M (B180))								
7	ENGINE TYPE						D	DIESEL ICE								
							E	BEV								
							H	HYDROGEN ICE								
							F	HYDROGEN FCEV								
							C	CNG ICE								
8	TRANSMISSION TYPE						A	AUTOMATIC TRANSMISSION								
							M	MANUAL TRANSMISSION								
							N	NEES TRANSMISSION								
							O	NO TRANSMISSION								
9	CHECK DIGIT						*	TO BE DEFINED INDIVIDUALLY FOR EACH VEHICLE VIA CHECK DIGIT CALCULATION.								
10	MODEL YEAR						R	2024								
							S	2025								
							T	2026								
							V	2027								
							W	2028								
							X	2029								
							Y	2030								
11	ASSEMBLY PLANT						A	AIOS GEBZE PLANT								
							K	Reserved								
							U	Reserved								
12-17	PRODUCTION SEQUENCE NO															

### ADVICE

- Interpretation of the VIN may differ depending on the market. For further details, please ask your Isuzu Dealer.

### ENGINE NUMBER

The engine number is stamped both on the engine identification label on the cylinder head cover and on the body of the oil cooler on the engine block.

## IMPORTANT INFORMATION

### BEFORE DRIVING

Proper care and driving is important not only in extended service life of your vehicle, but also in improved fuel and oil economy. Drive carefully and defensively.

### PERFORM DAILY INSPECTIONS

For safe and comfortable driving, keep record of the distances driven and the condition of the vehicle during operation. Perform inspections at appropriate intervals, and perform maintenance in accordance with the findings of the inspections. If an inspection reveals an abnormality or there was an abnormality the previous time the vehicle was driven, have the vehicle repaired by the nearest Isuzu Dealer before it is driven again.

Daily Inspections Check List:

1. Checking components that showed abnormalities during the previous operation
2. Fan belt looseness and damage
3. Engine oil level
4. Transmission oil level
5. Engine coolant level
6. Power steering fluid level
7. Brake fluid level
8. Brake pedal free play
9. Exhaust sound from brake valve
10. Increase in air pressure
11. Operation of meters, gauges and warning/indicator lights
12. Engine startability, abnormal noise and color of exhaust gases
13. Parking brake lever stroke
14. Windshield washer fluid spray condition and windshield wiper effectiveness
15. Windshield washer fluid level
16. Steering wheel free play and mounting condition
17. Operation of horn and turn signal lights
18. Fuel level
19. Illumination, flashing or damaged lights
20. Battery fluid level
21. Condensation in air tank
22. Leakage of oil, engine coolant, fuel, brake fluid, power steering fluid
23. Water collecting in the fuel filter
24. Air pressure
25. Cracks and other damage
26. Abnormal wear
27. Tread depth of tires
28. Disc wheel mounting condition
29. Brake effectiveness
30. Checking the engine at low speeds and acceleration

### USE THE SPECIFIED FUEL

#### CAUTION

- For models conforming to Euro IV emission standards, be sure to use low sulfur diesel fuel (containing sulfur of 50 ppm or lower) or extra-low-sulfur diesel fuel (containing sulfur of 10 ppm or lower). For models conforming to Euro V or Euro VI emission standards, be sure to use extra-low-sulfur diesel fuel (containing sulfur of 10 ppm or lower) (DIN EN 590)
- The use of a poor-quality diesel fuel, mixing such an additive as water remover to the fuel in the tank, or filling the tank with gasoline, kerosene or an alcohol based fuel or its mixture with a diesel fuel will badly affect the fuel filter and result in lubrication problems in fuel-lubricated components of the injectors. In addition, this practice can also impair the operation of the engine and the diesel particulate filter (DPF), the urea selective catalytic reduction (SCR) system, the exhaust emission cleaning system, possibly leading to breakdown of the engine-related systems. If an incorrect fuel should accidentally be added, drain all fuel from the system. Failure to observe this precaution can result in a fire or permanent damage when the engine is started.
- Using diesel fuel other than extra-low-sulfur diesel fuel or low-sulfur diesel fuel in a model conforming to Euro IV emission standards, or using diesel fuel other than extra-low-sulfur diesel fuel in a model conforming to Euro V or Euro VI emission standards could prevent the vehicle from complying with local legal requirements.
- Open the fuel tank filler cap slowly. If you open it quickly, fuel may spurt out.
- Paraffinic fuels to be used (including hydrogen-treated vegetable oils (HVO) fuels) must meet the ASTM D975 standard together with the DIN EN15940 standard.
- If a biodiesel fuel mixture is to be used, the rate of biodiesel can be 20% at most.
- Fuel other than the above-mentioned fuels should not be used without consulting the relevant authorized service.

---

### USING SELF-SERVICE FILLING STATIONS

#### WARNING

[Be sure to obey the following instructions when refueling the vehicle]

- Stop the engine and close the vehicle's doors and windows.
- Keep cigarettes and other flames away from the vehicle.
- Before opening the fuel tank filler cap, touch a metallic object to discharge static electricity from your body. If you have a static charge buildup on your body while refueling the vehicle, a spark caused by its discharge could ignite the fuel, resulting in burns.
- When filling, place the nozzle deeply into the fuel tank. If you try to fill more fuel by pulling out the nozzle from the fuel tank, the fuel may spill out, thus causing danger.
- All parts of the refueling procedure (from opening the fuel tank filler cap to completing the refueling and closing the fuel tank filler cap) must be performed by the same person. Other people may be carrying static electricity. Do not allow them to approach the fuel filler. The person performing the refueling procedure must not return to the seat in the cab part-way through the procedure. He/she could pick up another charge of static electricity by doing so.
- Obey all cautions posted in filling stations.
- Be sure to wipe off the fuel that is spilled at refueling.

#### CAUTION

- Be careful not to inhale fuel vapor when refueling the vehicle.

---

## ECONOMICAL DRIVING

Driving too fast or driving so slowly that the engine knocks can lead to poor fuel economy.

In vehicles with retarder, driving with the retarder switched on all the time or using the retarder frequently to adjust your speed can also lead to poor fuel economy.

Drive at a constant speed as much as possible. When accelerating, increase your speed gently and slowly. Warming up the engine for longer than necessary and revving the engine are a waste of fuel. Driving with the vehicle overloaded is also a waste of fuel. Frequently check the tire pressures and make sure they are always correct.

---

## DO NOT CARRY FUEL AND SPRAY CANS IN THE CAB



### WARNING

- It is extremely dangerous to carry fuel and spray cans in the cab. If such a container were to ignite or rupture, it could cause a fire or explosion.

---

## KEEP THE FLOOR AROUND THE DRIVER'S SEAT CLEAN AND TIDY



### WARNING

- It is extremely dangerous to have empty cans, empty bottles or other items rolling around on the floor because they could get trapped under the brake pedal and prevent brake application. For proper pedal operation, it is also essential to lay floor mats properly. Incorrectly installed floor mats would hinder free movement of the pedals.
- Do not use the dashboard pocket or the top of the dashboard as a place to put items that could roll, which could interfere with your driving.

---

## CHOOSE YOUR FOOTWEAR SUITABLE FOR DRIVING

### CAUTION

- Choose footwear that ensures proper operation of pedals when driving the vehicle. Use of footwear unsuitable for driving may cause an accident.

**CORRECT DRIVING POSTURE**

**WARNING**

- Before driving, be sure to adjust the seat, steering wheel and mirrors to positions that give you a correct driving posture. Make sure the seat is securely retained by trying to rock it forward and backward, and put on the seat belt. All other passengers must wear seat belts.

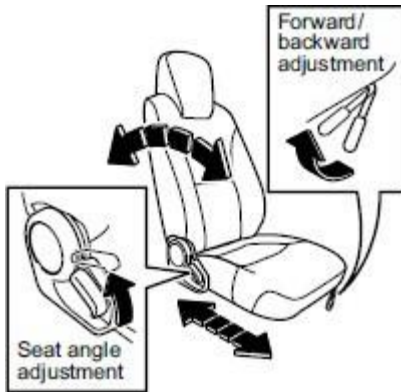

**Seat Adjustment**

Adjusting the seat for a correct driving posture is a fundamental part of safe driving.

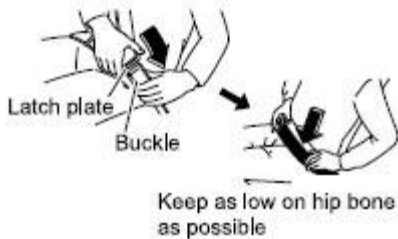

**Fastening Your Seat Belt**

Be sure to wear your seat belt. Sit up straight with your lower back pressed against the seat and the lap belt as low on your hips as possible.



**Seat adjustment recommendations**

- a Make adjustments that allow you to easily turn the steering wheel with your elbows slightly bent.
- b Position the seatback so it is always touching your shoulders.
- c Make sure you can adequately press each pedal.

**Seat belt fastening cautions**

- A Position the lap belt as low on your hips as possible.
- B Position the shoulder belt so it is on your shoulder.
- C Make sure the seat belt is not twisted when you put it on.

## DRIVING

Proper care and operation will not only extend the service life of your vehicle but also improve oil and fuel economy.

### OPERATION OF NEW VEHICLE

The subsequent performance and the service life of your vehicle are under the direct influence of the care and treatment that your vehicle will receive during the initial break-in period. It is therefore always recommended that during the initial 1,000 km (600 miles) break-in period, the following few simple precautions are carefully observed.

1. It is recommended that the engine speed is restricted.
2. Always let the engine idle until it becomes thoroughly warmed up.



Speed bumps should be crossed at a maximum speed of 15 km/h.

### CHECK AROUND THE VEHICLE BEFORE STARTING THE ENGINE

Before pulling away, perform a thorough safety check, making sure there are no children or obstructions around the vehicle.

#### WARNING

- Before starting the engine, make sure there is no flammable material under or around the vehicle. The presence of any such material could lead to a fire. If there is any wood within 50 cm (approximately 20 in) from the vehicle's heat source, it would represent a severe hazard as the wood could deform or discolor from the heat or it could catch fire.

### BE CAREFUL ABOUT EXHAUST EMISSIONS

#### WARNING

- Exhaust emissions contain carbon monoxide, which is colorless, odorless and poisonous. If you inhale exhaust emissions, you may suffer carbon monoxide poisoning.
- Do not keep the engine running for any length of time in a place that is poorly ventilated. It is particularly dangerous to run the engine in a garage or other indoor place that could easily fill with exhaust gases because you could suffer carbon monoxide poisoning.
- Inspect the exhaust pipe from time to time. If you notice any defect (for example, a damaged joint, or a hole or crack caused by corrosion), have checks and maintenance performed by the nearest Isuzu Dealer. Continuing to use the vehicle without having the defect repaired would be dangerous because exhaust gases could get into the cab and cause carbon monoxide poisoning.
- If exhaust gases get into the cab, completely open all of the windows and place the inside/outside air selector of the heater or air conditioner to outside air. Promptly have checks and maintenance performed by the nearest Isuzu Dealer. Continuing to use the vehicle without having the defect repaired would be dangerous because exhaust gases could get into the cab and cause carbon monoxide poisoning.

---

## STARTING THE ENGINE

Bring main switch to “ON” and the transmission to “N” position. By bringing the ignition switch to “M” position, turn it and press the starter button (“D” position).



Do not run the starter more than 30 seconds and do not press the accelerator pedal while operating. Wait two minutes between every attempt to run.



If the engine oil warning light does not turn off in 15 seconds, stop the engine in order to prevent the harm of it. Apply to the authorized service.



After starting the engine, run at idle for 3-5 minutes, increase the engine speed slowly. Do not run the engine over maximum speed, this may cause serious damages to the engine.

---

## STARTING THE ENGINE IN COLD WEATHERS



Bring main switch to “ON” and the transmission to “N” position. By bringing the ignition switch to “M” position, when the glow light turns off, turn the ignition switch (“D” position) and press the starter button.



If the vehicle would stay in parking for a long time (more than 1 days), bring the main switch to off position.

---

## IF THE VEHICLE HAS NOT BEEN USED FOR A LONG PERIOD ADVICE

- Before using a vehicle that has not been driven for a long period, check the engine, transmission and transfer case for oil leakage, and make sure the oil is at the required levels. If there is insufficient oil, it will not adequately reach and lubricate components, and a breakdown will result.
- Replace the urea® for vehicles that have not been used for a year or more. Failure to do so may result a failure of the urea selective catalytic reduction (SCR) system.
- Start the engine and allow it to idle for at least 5 minutes. Check for abnormal noises.
- For instructions on warming up the engine, refer to "Starting the Engine".

## MAIN SWITCH OFF

- When the engine stops, it enters sleep mode powered by the battery for approximately 2 minutes, performing processes such as AdBlue withdrawal. If the switch is turned off and the engine is stopped, it will not have the opportunity to perform these processes. Failure to perform these processes will cause damage to the engine and other equipment over time. **Turning off the switch is not suitable for daily use. It is recommended for use only in emergencies.**

## RECOMMENDATIONS FOR WARMING UP THE ENGINE

The engine is sufficiently warmed up when the needle of the engine coolant temperature gauge starts to move.

### ADVICE

- Do not rev the engine or quickly accelerate before the engine has sufficiently warmed up (in other words, when the engine is cold). Oil would not have adequately reached and lubricated components, so a breakdown would result.
- The exhaust pipe becomes extremely hot while the engine is idling. Before warming up the engine, make sure there is no flammable material (for example, grass, waste paper, oil or old tires) near the exhaust pipe.

## DO NOT RUN THE ENGINE IN A GARAGE

### WARNING

- Running the engine in a poorly ventilated place can lead to carbon monoxide poisoning. Start and warm up the engine only in places that have good ventilation. Also, on diesel particulate filter (DPF) equipped models, do not perform manual DPF regeneration indoors. Combustion of particulate matter (PM) during DPF regeneration produces white smoke.

## DO NOT FORGET TO RELEASE THE PARKING BRAKE

### CAUTION

- Pulling away with the parking brake still engaged can result in brake failure or a fire.

### ADVICE

- The parking brake lever can be collapsed by pulling the latch (if equipped) when the parking brake is engaged.
- Pulling away with the parking brake still applied can damage the brake system.
- The red sticker under the latch (if equipped) on the parking brake lever should not be visible. Before pulling away, make sure the parking brake is not engaged by checking that the parking brake warning light is off.

## NEVER STOP ENGINE WHILE DRIVING



### WARNING

- Do not move the starter switch away from the "ON" position while the vehicle is being driven. If the engine stops while the vehicle is moving, the brakes would not work properly, and the steering wheel and clutch pedal would become extremely stiff and hard to operate. The transmission could also be damaged.
- Stopping the engine while driving would be extremely dangerous because the power steering would stop working, making the steering wheel extremely hard to turn.
- Stopping the engine while driving would be extremely dangerous because the warning lights, indicator lights and other electrical circuitry would completely stop working.
- Placing the starter switch in the "LOCK" position while driving would be extremely dangerous because the key could come out, causing the steering wheel to lock so that you could not turn it.

## SIDEWINDS

### ADVICE

- If the vehicle catches a side wind and drifts sideways, firmly grip the steering wheel, decelerate to a speed that allows you to stay completely in control and make a directional correction. The vehicle may catch strong side winds in the following situations:
  - emerging from a tunnel; driving over a bridge, driving on an embankment
  - being overtaken by a large truck or bus
  - overtaking a large truck or bus

---

## DEALING WITH A BLOWOUT OR FLAT TIRE WHILE DRIVING

### WARNING

- If you feel any abnormality in a tire while driving, immediately stop in a safe place. If you continue to drive on a flat tire, undue force would be applied to the wheel bolts, possibly causing the bolts to break and the wheel to come off.

### ADVICE

- If a blowout or flat tire occurs while you are driving, calmly grip the steering wheel and gradually apply the brakes to decelerate. (Hard braking would be dangerous because it could cause the steering wheel to be pulled to one side.) Stop the vehicle in a safe place, and change the tire.

---

## IF THE UNDERSIDE OF THE VEHICLE RECEIVES A HARD BUMP

### ADVICE

- If the underside of the vehicle receives a hard bump, stop in a safe place where the vehicle will not obstruct traffic and check for brake fluid leakage (hydraulic brake models), air leakage (full-air brake models), fuel leakage and component damage. If any part of the vehicle is damaged or broken, promptly have the vehicle inspected and repaired by the nearest Isuzu Dealer.

---

## IF A WARNING LIGHT OR INDICATOR LIGHT COMES ON

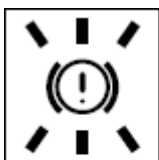

### ADVICE

- If a warning light comes on or flashes, do not ignore it and keep driving. Be sure to take corrective action referring to the explanation of the meters, warning lights and indicator lights.



---

## STOPPING AND PARKING

### PARKING

#### ADVICE

- Choose a flat place where stopping and parking are permitted and where the vehicle will not obstruct traffic. Firmly apply the parking brake and make sure the vehicle does not move.
- Remove all dirt from the vehicle's light lenses and reflectors to ensure that the vehicle can be seen from other vehicles.

---

### APPLYING THE PARKING BRAKE

#### ADVICE

- Except in an emergency, do not apply the parking brake until the vehicle has come to a complete stop. Applying the parking brake before the vehicle has stopped can cause the tires to lock or the vehicle to spin, possibly causing an accident.

---

### PARKING SAFELY ON A SLOPE

#### CAUTION

- Avoid parking your vehicle on a slope as much as possible and choose a level and flat place. If it is unavoidable to park your vehicle on a slope, be sure to set the parking brake fully, make sure that the vehicle does not move, and block the wheels with chocks for added safety. Also, leave the vehicle in gear to further ensure that it will not move.
- Leave the steering wheel turned such that the vehicle will be stopped by an obstruction (for example, the curb) in the unlikely event that it moves.

---

### STOPPING AND PARKING WITH THE ENGINE RUNNING

#### WARNING

- When stopping and parking with the engine running: If your vehicle is equipped with a manual transmission, be sure to place the gearshift lever in the "N" position to select neutral. With a Smoother vehicle, make sure the shift indicator is showing "N" (Smoother models without P-range) or "P" (Smoother models with P-range). Then, firmly apply the parking brake. Unless you take these steps, any unintended pressure on the accelerator pedal could cause an accident.

#### CAUTION

- On diesel particulate filter (DPF) equipped models, the DPF may automatically start regeneration when the vehicle is stopped and parked with the engine running. To prevent a fire, make sure there is no flammable material near the muffler, DPF, urea selective catalytic reduction (SCR) system, and exhaust pipe. Be careful not to get burned by hot exhaust gases.

---

## BE SURE TO HAVE THE ENGINE RUNNING WHEN THE VEHICLE IS MOVING

### CAUTION

- When the engine is not running, the power steering system does not work so the steering wheel is hard to turn. Also, the brake booster does not work so there is little braking ability. If you coast down a slope without the engine running, you would not be able to properly control the vehicle and could have an accident.

---

## LOOK AROUND BEFORE OPENING A DOOR

### CAUTION

- Before opening a door, check the area around the vehicle by looking forward, rearward and to the sides. If you suddenly open a door without checking the surrounding area, the door could be hit by a vehicle behind you or a pedestrian.

---

## LEAVING THE VEHICLE

### WARNING

- When leaving the vehicle, be sure to apply the parking brake, stop the engine. Do not leave valuables where they can be seen from outside the vehicle.
- If you are traveling with a child, do not leave the child alone in the vehicle. If the child touches the controls or equipment, an accident could occur. (For example, the vehicle could move or a fire could start.) Also, the cab inside could become dangerously hot in hot weather.
- Do not leave eyeglasses or a lighter in the vehicle. If the cab inside becomes hot, a lighter left there could explode and plastic eyeglass lenses or frames could deform or crack.
- Do not leave your vehicle unattended with the engine running. If the engine should overheat, you would not be there to react to the temperature warning light or gauge. This could result in costly damage to your vehicle and its contents.

---

## STARTING TO DRIVE WHEN THE VEHICLE HAS BEEN PARKED

Before pulling away, perform a thorough safety check, making sure there are no children or obstructions around the vehicle.

---

## REVERSING

If you cannot see the area behind your vehicle well enough to confirm it is safe to back up, get out of the vehicle and check behind it.

---

## PULLING AWAY AFTER A TEMPORARY STOP

### CAUTION

- Make it a habit to look around and confirm that it is safe to pull away after a temporary stop (at traffic lights, for example).

## **DIESEL PARTICULATE FILTER (DPF)**

DPF reduces particulate matter (PM) in the exhaust emissions. The DPF filter captures PM. When a certain amount of PM has accumulated in the DPF filter, the filter is automatically regenerated. (The PM is burned away.) To prevent a DPF failure, be sure to observe the following points:

### **WARNING**

- The DPF, urea selective catalytic reduction (SCR) system, and exhaust pipe are extremely hot while the engine is running, during DPF filter regeneration (PM combustion), and immediately after vehicle operation. Be careful not to inadvertently touch them. Otherwise, you could be burned.
- Any grass, waste paper or other flammable material near the vehicle could catch fire.
- Before doing maintenance work on the vehicle, shut down the engine and allow it to cool down. Otherwise, you could be burned.

### **CAUTION**

- Using diesel fuel other than extra-low-sulfur diesel fuel (with sulfur content no higher than 10 ppm) for a vehicle equipped with a DPF/urea SCR could prevent the vehicle from complying with local legal requirements.

## ADVICE

- Use Isuzu genuine engine oil compatible with the DPF. Using oil other than Isuzu genuine engine oil compatible with the DPF would shorten the time between DPF filter cleaning and could increase fuel consumption.
- For models conforming to Euro IV emission standards, be sure to use low sulfur diesel fuel (containing sulfur of 50 ppm or lower) or extra-low-sulfur diesel fuel (containing sulfur of 10 ppm or lower). For models conforming to Euro V or Euro VI emission standards, be sure to use extra-low-sulfur diesel fuel (containing sulfur of 10 ppm or lower).
- If you fill the vehicle with poor-quality fuel, water-removing additive or other additive, gasoline, kerosene or alcohol-based fuel, it could harm the fuel filter, prevent proper movement of fuel-lubricated parts in the injectors and adversely affect engine components, possibly resulting in a breakdown.
- Do not modify the DPF, urea SCR, or exhaust pipe. Changing the alignment, length or diameter of the exhaust pipe would adversely affect the exhaust system's exhaust emission reduction function. If any modification is necessary to install a component to the rear of the vehicle, consult your Isuzu Dealer.
- Although the DPF filter automatically undergoes regeneration (burning of the accumulated PM) when a certain amount of PM has accumulated, driving conditions can prevent completion of regeneration. In a model without multi information display (MID), the DPF manual regeneration indicator light will flash at this time. In a model with MID, the "PUSH DPF SWITCH" indicator (amber) will flash. Perform manual regeneration in accordance with the proper procedure. This is to restore DPF function and is normal.
- If the vehicle is left in gear during regeneration, the regeneration time could be extended, possibly having an effect on fuel consumption. Leave the transmission in neutral when idling the vehicle for extended periods of time.

## NOTE

- If the vehicle is stationary with the engine idling during DPF regeneration, the exhaust brake or exhaust throttle operates. Operating sounds will be heard when the exhaust brake or exhaust throttle is activated or deactivated. The sounds do not indicate a fault.
- Combustion of PM during DPF regeneration can cause white smoke to be briefly emitted from the exhaust pipe. The white smoke does not indicate a fault. Do not perform manual regeneration in any poorly ventilated indoor place.
- When a new vehicle has been driven a certain distance, it can emit white smoke during DPF regeneration. The white smoke does not indicate a fault. The vehicle may not emit white smoke during its initial operation when new.
- Owing to the exhaust emission reduction function, the exhaust gases emitted by the exhaust pipe smell different from those emitted by the exhaust pipes of earlier diesel vehicles.
- The exhaust brake may automatically be activated in order to prevent emission of white smoke if the engine idles continuously over an extended period of time.
- A long continuous idling can cause white smoke to be briefly emitted from the exhaust pipe. The white smoke does not indicate a fault.
- The DPF may start operating and the engine speed may increase after a long continuous idling or driving with low speed.

## UREA SELECTIVE CATALYTIC REDUCTION (SCR)

The urea SCR system reduces nitrogen oxides (NOx) in exhaust emissions. The nitrogen oxides (NOx) are then reduced to nitrogen and water and purified by the generated ammonia.

### CAUTION

- Do not touch any water discharged from the muffler. In case of contact with skin, wash off thoroughly with water.

### ADVICE

- Do not modify the exhaust pipe or muffler, or change the location of any items including the urea<sup>®</sup> tank. Doing so could affect exhaust emission reduction capabilities. If any modifications or relocation is necessary, consult your nearest Isuzu Dealer.

### NOTE

- Exhaust emissions from the tailpipe have a smell different from those emitted from vehicles without urea SCR systems due to the exhaust emission reduction functions of the exhaust system.
- Urea<sup>®</sup> is a registered trademark of Verband der Automobil industrie (VDA).

---

## HANDLING OF UREA<sup>®</sup>

Urea<sup>®</sup> is a clear, colorless, and harmless aqueous solution. It is normal for urea<sup>®</sup> to emit an odor in some circumstances.

### CAUTION

- Urea<sup>®</sup> is harmless to the human body even if touched. However, it may cause inflammation in rare circumstances depending on its constitution. In such cases, take the following actions.
  - In the case of contact with skin, wash off with water. Failure to do so may result in irritation for those with sensitive skin.
  - In the case of accidental ingestion, drink one or two glasses of water or milk and consult your physician immediately.
  - In the case of contact with eyes, immediately wash out with large amounts of water for at least 15 minutes and consult your physician.

---

## IS A SPECIFIED UREA<sup>®</sup> BEING USED?

- Use Urea<sup>®</sup> specified by Isuzu.
  - Use Urea<sup>®</sup> that is compliant with the ISO (International Organization for Standardization) 22241 standard defined for AUS 32.

---

## STORING UREA®

- Seal the Urea® container to prevent evaporation and store it indoors or in places that are well ventilated and not exposed to direct sunlight.
- When stored, the expiration date of Urea® varies depending on the temperature of the storage location. Contact your Isuzu Dealer for details.

## NOTE

- Even if frozen, Urea® retains the same quality as when thawed and is usable as is.
- When storing or carrying Urea®, use the container in which the Urea® was contained when purchased. If not, use a dedicated polyethylene tank (PE) or stainless steel container that is free from any adhesion of foreign materials such as water or dust.

---

## REFILLING UREA®

### WARNING

- Do not put anything other than Urea® in the Urea® tank.
- When refilling Urea®, doing any of the following may cause a fire or malfunction of the urea SCR system.
  - Diluting with water or other liquids
  - Adding gasoline or diesel fuel
- If liquids, etc., other than the specified Urea® have been accidentally added, the urea SCR system must be inspected. Have the urea SCR system inspected/serviced at your Isuzu Dealer.

### CAUTION

- Urea® rarely emits an odor when the tank cap is opened. Do not attempt to smell the tank from the supply inlet.

### ADVICE

- Remember to add Urea® early so that the tank is always fully filled with Urea®.
- Do not fill with Urea® over the "F" line on the level gauge. Doing so may result in leakage of Urea® from the breather hose during driving. In addition, if Urea® freezes, sensors may be damaged.
- Do not step or ride on the Urea® tank. Doing so may result in damage to the Urea® tank, pipe, and sensors.
- The urea SCR system will continue to operate for approximately 3 minutes after the starter switch is set to the "LOCK" position. Wait for 3 minutes or longer when removing the battery or power line connectors for inspection or repair.

**NOTE**

- The level gauge, mounted in front of the urea<sup>®</sup> tank, is intended to prevent oversupply and overflow of urea<sup>®</sup>, not to measure the remaining amount of urea<sup>®</sup>. Even when the surface level of the urea<sup>®</sup> reaches the lower end of the level gauge, the urea<sup>®</sup> amount display on the meter panel still indicates levels 4 or 5. Check the remaining amount of urea<sup>®</sup> on the urea<sup>®</sup> amount display, not using the level gauge.
- Operating noises may be heard from the urea<sup>®</sup> tank or supply module after the engine stops. This is the sound of urea<sup>®</sup> returning from the pipe to the urea<sup>®</sup> tank and is normal.

**DISPOSING OF UREA<sup>®</sup>**

Do not dispose of urea<sup>®</sup> or its empty containers into lakes, seas, rivers, or other such places.

Dispose of in an appropriate way complying with local legal requirements.

**ENGINE ROOM FIRE DETECTION SYSTEM**

If the engine room temperature exceeds 175°C the engine room fire detection warning light come on and warning buzzer will sound.

**VEHICLE DATA COLLECTION**

Your vehicle, like other modern motor vehicles, has a number of sophisticated computer systems that monitor and control several aspects of the vehicle's performance. Your vehicle uses on-board vehicle computers to monitor emission control components to optimize fuel economy, to monitor conditions for airbag deployment and, if so equipped, to provide anti-lock braking and to help the driver control the vehicle in difficult driving situations. Some information may be stored during regular operations to facilitate repair of detected malfunctions.

Isuzu may download and retrieve stored information for the purpose of diagnosing, servicing, or repairing your motor vehicle or improvement to future Isuzu motor vehicles.

## EQUIPMENT AND ACCESSORIES

### OPENING AND CLOSING DOORS

The front door of the vehicle is opened/closed from the outside with the remote control.

There are door open/close switches in front control panel in order the doors to be opened/closed from the inside.

#### CAUTION

- Be sure to do the following whenever you leave the vehicle:
  1. Fully engage the parking brake.
  2. Stop the engine.
  3. **Lock the doors.**
- When you close the door after sitting behind the wheel, check that the door is fully closed. If the door is not properly closed, it may open while the vehicle is in motion.
- Before opening the door, carefully check all areas around the vehicle for safety, especially the area at the rear of the vehicle.
- Never leave the key in the vehicle.

### OPENING DOORS IN AN EMERGENCY

#### Emergency Switch

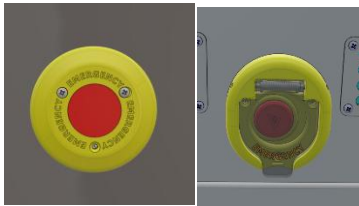

The emergency switch is located above the doors.

When these buttons inside and outside the vehicle are pressed, the door disengages and can be moved manually.

#### NOTE

- Exterior emergency switch next to the doors makes it possible for rescuers to gain access to the vehicle interior from the outside in the event of an emergency or an accident.

#### Emergency Hammer



The hammer can be used to break the glass panel in the emergency exit.

## WHEELCHAIR RAMP

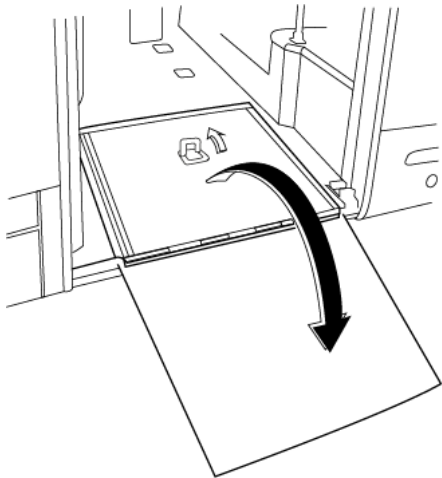

### CAUTION

- When setting the wheelchair ramp plate, be careful not to get your hand between the ramp plate and the ground.
- If a load exceeding the allowable load (365 kg) of the ramp plate is placed, damage to the ramp plate may lead to an unexpected accident.

### WARNING

- When using the wheelchair ramp, remember to apply the handbrake, shift the gear lever to the “N” position, and open the middle or rear door. It is very dangerous for the vehicle to move.

### When Using the Wheelchair Ramp

The wheelchair ramp is stored on the floor of the middle door.

1. Open the middle door.
2. Pull up the handle, turn over the ramp plate and unfold it.

## SEATS

The driver's seat must be adjusted so that when you sit well back in the seat, you can fully depress the pedals without moving your back from the seatback, and you can operate the steering wheel easily and freely. After making adjustments, check that the seat is completely locked.

Adjusting the seat for a correct driving posture is a fundamental part of safe driving.

### WARNING

- Adjust the seat only before you start driving. Adjusting the seat while the vehicle is in motion must be avoided not only because the unlocked seat will move back and forth unstably, preventing you from taking the correct position, but might also cause you to lose control of the vehicle, possibly resulting in an accident.
- Try to move the seat without unlatching it after making adjustments to check that it is completely locked. A loosely locked seat may move unexpectedly and your position might then become unstable; this could lead to an accident. Take the vehicle to your Isuzu Dealer for service if you find that your seat adjusters do not latch.
- Driving with the seat excessively reclined could be very dangerous in a collision or sudden stop. Raise the seatback, and wear the seat belt correctly while sitting well back and straight up in the seat.
- Do not place a cushion or similar object between your back and the seatback. Doing so not only affects the stability of your driving position but also prevents the seat belt from working effectively in the event of a collision.
- Do not place any objects under the seat. If there are any objects under the seat, the seat could be locked in an improper position.
- Before making adjustments, check that the seat rails are free of anything that could obstruct the locking of the seat. Be careful that your hand or foot does not become trapped in the seat or rails when adjusting the seat.

### DRIVERS SEAT

#### NOTE

- The location of the seat functions may vary depending on the vehicle.

#### Ergonomic Position



Before you start driving, the seat must be adjusted to an optimal position for your body and the correct seating posture must be taken, particularly when switching vehicles.

Attention to detail is imperative to adjust the seat to an optimal position for your body. An incorrectly set seat or a wrong seating posture may have a negative impact on the ergonomics, driver's body, and operating capacity the vehicle.

An improper adjusted seat may affect the ability to operate of the vehicle properly in a safe manner. Proper settings prevent accidents which may cause serious or fatal injuries.

A	Angle of elbow joints	95° - 135°
B	Angle of hip joint	100° - 115°
C	Angle of knee joint	110° - 120°
D	Angle of feet joint	90°

#### WARNING

- Adjust the seat only before you start driving. Adjusting the seat while the vehicle is in motion must be avoided not only because the unlocked seat will move back and forth unstably, preventing you from taking the correct position, but might also cause you to lose control of the vehicle, possibly resulting in an accident.
- Try to move the seat without unlatching it after making adjustments to check that it is completely locked. A loosely locked seat may move unexpectedly and your position might then become unstable; this could lead to an accident. Take the vehicle to your Isuzu Dealer for service if you find that your seat adjusters do not latch.
- Driving with the seat excessively reclined could be very dangerous in a collision or sudden stop. Raise the seatback, and wear the seat belt correctly while sitting well back and straight up in the seat.
- Do not place a cushion or similar object between your back and the seatback. Doing so not only affects the stability of your driving position but also prevents the seat belt from working effectively in the event of a collision.
- Do not place any objects under the seat. If there are any objects under the seat, the seat could be locked in an improper position.
- Before making adjustments, check that the seat rails are free of anything that could obstruct the locking of the seat. Be careful that your hand or foot does not become trapped in the seat or rails when adjusting the seat.

### Horizontal Slides



This enables the drivers to perform their job in a comfortable position. It provides a better view and easier access to the dashboard.

Pull the lever completely and move seat forwards/backwards. Once you have found your desired position, release the lever to lock the seat in place.

### CAUTION

- Make sure that you adjust the horizontal slides to a position, where you can reach and press the pedals to the stop without effort. Do not put your feet on the slide handle.

### Seat Cushion Adjustment

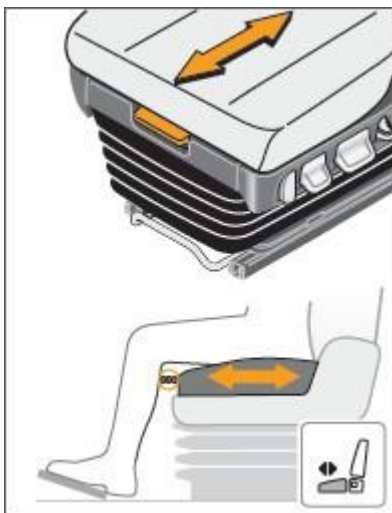

Enables the drivers to adapt the length of the cushion to the length of their thighs for optimal support.

It helps to keep the feet and lower legs from “falling asleep” and provides a safer and more fatigue-proof posture.

Pull the lever and move the seat cushion forward/backward. Adjust the cushion so that 3 fingers fit in between the cushion’s front edge and behind the operator’s knee.

Release the lever to lock the seat cushion.

### Swivel Adjustment

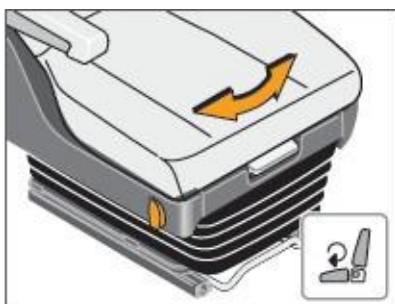

Serves as a help when entering and leaving the vehicle and preserves the seat cushions’ edge. Furthermore, it enables the driver to take a frontal direction also during jobs on the side like collecting.

Press switch and swing the seat. The seat can only be locked facing the engine. Turn the seat slowly to the locking position, to avoid a damage of the blocking catch and the stop.

### Seat Lowering

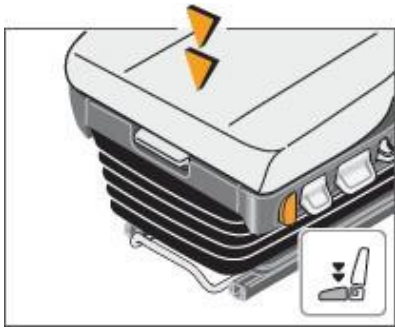

Enables the drivers to enter and to leave the vehicle much easier. Protects the seat cushion's side edge by reducing load and friction.

Press button down:

Seat moves downwards to the lowest position for easy exit and easy entry.

Press button up (when seat is lowered):

Seat returns by memory function to the previously set position.

### CAUTION

- Such a completely lowered seat is not allowed for driving because there is no air suspension available in that position.
- Before driving, the seat must be removed to the previously set position by pushing the button up.
- This lever is not a height adjustment (see below).

### Tilt Adjustment

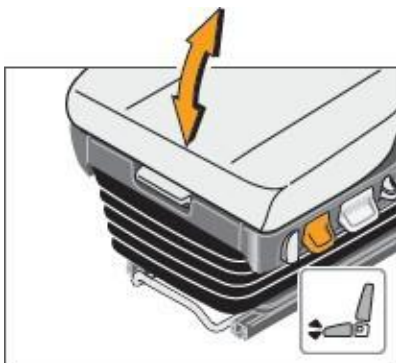

Enables the driver to reduce the load on the underside of the thighs and the back, respectively the intervertebral disc. The load depends on the inclination of seat and backrest.

Pull lever and adjust the tilt by loading/unloading the front seat cushion area.

After this the backrest shall be readjusted to an upright position.

### CAUTION

- Make sure that you adjust the seat inclination to a position, where you can reach and press the pedals to the stop without effort.
- The Backrest must not touch the cabin wall after adjustment.

### Height Adjustment

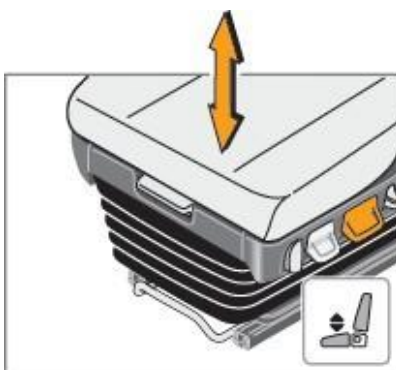

It supports the driver to reach the pedals comfortably and to pass through all the way without force.

Pull lever and adjust the desired height.

The higher the seat is lifted, the harder he will be suspended. The hardness can be readjusted by control "damper adjustment"

**CAUTION**

- Don't adjust the height so low that on rough roads the seat can knock through. Adjust the seat height in such a way, that the occupant on each road condition has enough head clearance to the ceiling of the cabin.
- Pedals must be actuated without stretching the legs completely.

**Damper Adjustment**



Protects the spine of the driver, as the damper absorbs the vertical shocks and vibrations. By adjusting the damper, the suspension characteristics of the seat can be optimally adapted to every roadway and every driver.

- |             |                 |   |
|-------------|-----------------|---|
| Lever up:   | Soft suspension | - Minimum damper force for flat roads.  |
| Lever down: | Hard suspension | - Maximum damper force for rough roads. |

**CAUTION**

- Damper adjustment must be adapted in case of changing road conditions.
- The damper shall be adjusted stiff enough, so that in rough road conditions the driver's feet never lose contact with the pedals.
- Don't adjust the damper so soft that on rough roads the seat can knock through. Take care for a sufficient distance to the cabin's ceiling.
- In general, heavy drivers don't have to use a soft adjusted damper.

**Lower Lumbar Support**



Promotes an upright posture and prevents fatigue by tuning the backrest contour. This modifiable shape of the lower backrest adjusts the position of the driver's pelvis by turning the pelvis forward and upright.

- Relaxation of muscles
- Load relief in the spine
- Increase in comfort

Press upper area of the button for blowing the air- chamber respectively the lower area for exhausting for turning the pelvis forward and upright.

This turns your spine into its ideal double S-shape.

The lumbar support prevents driving in a slouched or hunched position and prevents driving in a hollow- back position

### Upper Lumbar Support



Promotes an upright posture and prevents fatigue by tuning the backrest contour. This modifiable shape of the lower backrest compensates driver's hollow back.

- Relaxation of muscles
- Load relief in the spine
- Increase in comfort

Press upper area of the button for blowing the air- chamber respectively the lower area for exhausting to match the shape of the lower backrest contour in order to support fully the driver's back.

The lumbar support prevents driving in a slouched, hunched or in a hollow back position. Please note that your whole back must touch the backrest from the buttocks to the shoulders. Therefore, the lower lumbar support shall be adjusted firstly. It is recommended to change the sitting position from time to time.

### Side Bolster Support

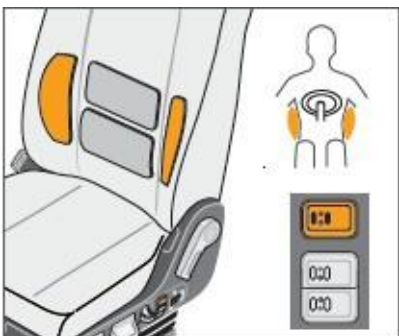

Promotes an upright posture and prevents fatigue by tuning the backrest's side contour. It prevents the back from sliding continuously across the backrest from side to side.

- Relaxation of muscles
- Load relief in the spine
- Increase in comfort

Press upper area of the button for blowing the air- chamber respectively the lower area for exhausting to adjust the bolsters of the backrest optimally to the driver's back width. The side bolster support prevents driving in a slouched position. It is recommended to change the sitting position from time to time.

## Backrest Adjustment



The backrest adjustment is needed to enable the driver an upright posture for having a good view to the traffic.

Press your back slightly against the backrest. Pull handle completely over the full adjustment stroke and adjust the backrest to the desired inclination by moving your back for- or rearwards.

### CAUTION

- The distance from the back of the head to the backrest should be kept as low as possible by a steeply adjusted backrest.
- Don't drive with a too much backwards folded backrest - this also applies to the passenger  
-in order to avoid the risk of sliding out of the belt during a full brake situation.
- Adjust the backrest to an inclination where the steering wheel can be reached with angled arms.
- Adjust the backrest only when sitting, otherwise the backrest moves forward quickly.
- Don't fold the backrest completely down to the seat cushion with force, in order to preserve the backrest's side bolsters.
- Don't sit or place anything on a backrest while folded down.
- A folded down backrest shall not be used as a method of ascent while entering the vehicle.
- After backrest adjustment readjust shoulder adaption and belt height adjustment.
- The Backrest must not touch the cabin wall after adjustment.

## Shoulder Adjustment



The shoulder adjustment enables a full flat contact with the backrest by inclination adjustment of the upper Backrest area. This adjustment allows an individual adaption of the seat to the length of the upper body.

Push switch and adjust the upper backrest area in the desired position.

### CAUTION

- The distance from the back of the head to the backrest should be kept as low as possible.
- The adjustment of the shoulder adaption must be matched to backrest inclination and belt height adjustment.

## 3-Point-Belt / Belt Height Adjustment

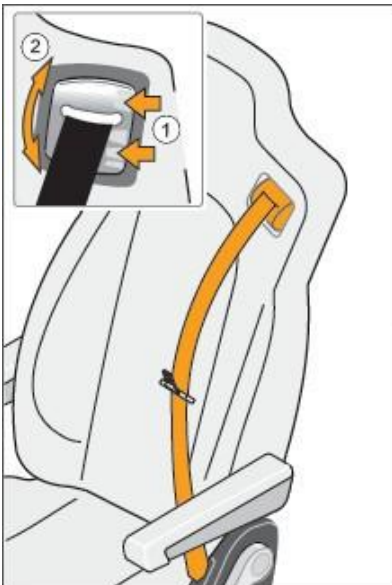

The belt height adjustment enables the adaption of the belt outlet to the body height of the driver. The Belt height adjustment must be matched to the inclination of the shoulder adaption.

Press roller on the outside (1) and swing the belt to the desired height (2) (7 steps possible). After releasing the roller, locking mechanism must engage hearable.

For adjusting the correct belt height, turn belt retainer in a way that the belt strap is running over the middle of the shoulder.

### CAUTION

- Take the buckle latch and pull the belt strap over your shoulder, upper body and pelvis. Push the buckle latch, hearable engaging, into the buckle. If you want to release the belt, push the red button at the buckle, take the buckle latch and lead the belt back to the rolled - up position.

- Make sure to use your seat belt always correctly for the whole duration of your drive. If you don't fasten your safety belt or if you don't fasten it correctly, the risk of severe injuries increases. Correctly fastened seat belts may abate the severity of injuries in case of accidents, hurling or hard braking. Never belt in more than one person per seat belt. Do not fasten anything else on the passenger seat than the person sitting there on or an accredited and suitable child seat.
- Don't twist the seat belt when fastening. Make sure that the belt tongue engages correctly and audibly in the belt buckle. The belt must stay close to the body. When unfasten, guide the belt tongue back to the belt exit in the backrest because an uncontrolled up rolling belt can evoke damages by the belt tongue or the belt doesn't roll up centrally, so that the edges of the belt webbing scrub.
- The leading of the belt strap is all important for an optimal protective effect of safety belts. Don't lead the belt strap in a way that it runs over breakable objects like mobiles or glasses because this can cause injuries or damages to the objects. Don't clamp the belt strap.
- Don't ever lead the belt anywhere else than over your shoulder and over your pelvis area.
- The belt must run over the middle of the shoulder, never along the neck and must lay tightly on the upper body.
- The belt must cross the pelvis area, tightly in front of the pelvis, never across the stomach.
- Voluminous and loose clothing decreases a correct running of the belt and by that an optimal function.
- Never change the belt's path by mounting belt strap clamps, belt stop knobs or the like.

**CAUTION**

- The armrest shall not be used as a method of ascent while entering the vehicle.

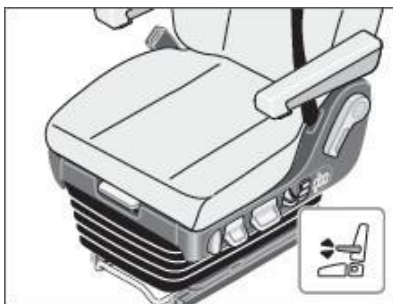
**Armrests**

Optimal adjustment of the armrests to relieve muscles in the spine and back.

Enables relaxation of muscles in shoulder and neck area. Reduces the load on the spinal disc in the low spine area. Adjust the armrest to a position where the elbows lay lightly on it.

Lift up armrest a little and adjust inclination step less by turning the wheel at the underneath.

**PASSENGER SEAT**

Passenger seats cannot be adjusted. The maximum number of wheelchairs, seated and standing passenger capacity of the vehicle is marked on the inside in the vicinity of the front service door.

**CAUTION**

- Baggage must not be placed on the center seat. If the baggage falls on the floor when the vehicle is braked, it may lead to an accident.

## 28 | EQUIPMENT AND ACCESSORIES

- 4 of the 8 seats in the priority passenger area are child seats. The child seats have the device marked in the image. After the parent sits in the seat on the aisle side, they should fasten the child's seatbelt and adjust the length of the belt to fit the child by threading it through the device next to the seat.

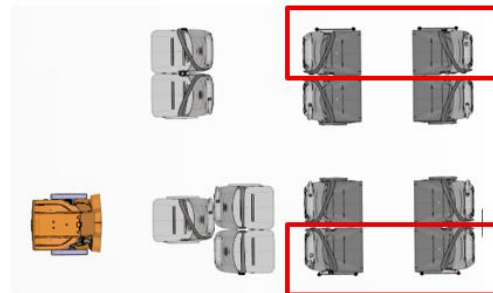

- There are three package areas in the front of the vehicle. Passenger luggage can be secured in these areas.

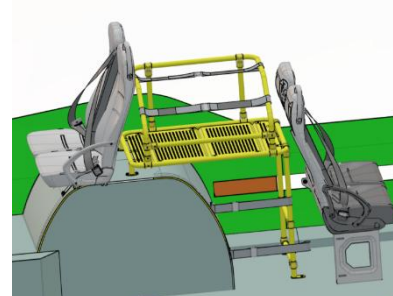
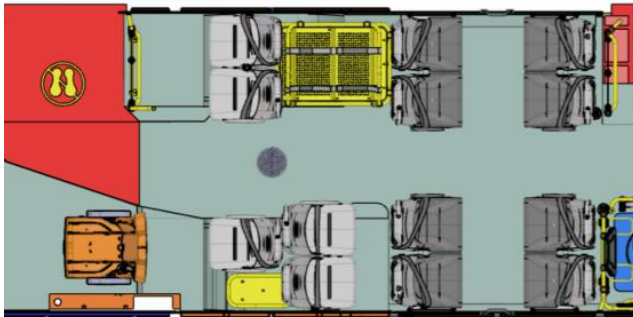

## MIRRORS

Sit in the correct driving position on the properly adjusted seat, and then check each mirror to ensure that it provides a proper view of the rear, the sides, the area just in front of the vehicle, and the area directly opposite to the driver's seat. Make adjustments if necessary and clean any dirty mirrors.

There is 1 internal rearview mirror available in the vehicle. There are 2 external rearview mirrors, one of which is at right and one is at left. The formation of condensation or ice in external mirrors is prevented by resistance heating.



RIGHT EXTERNAL REARVIEW

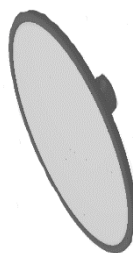

MIRROR, MIDDLE DOOR INSIDE

(OPTIONAL)



LEFT EXTERNAL REARVIEW

**CAUTION**

- Adjust the mirrors when the vehicle is stationary, not while the vehicle is in motion.
- When checking the rear of the vehicle with mirrors, be careful that this does not distract your attention from the traffic ahead.
- Rearview mirrors may make the vehicle behind you appear farther away than it really is. Use these mirrors very carefully until you are able to correctly determine distances from the images.
- Keep the mirrors in mind when passing another vehicle on a narrow road, moving the vehicle into a garage or driving near pedestrians.
- Do not drive with the mirrors folded.

**ROLLER BLIND**

The roller blind protects your eyes in strong sunlight. Use it when sunlight is too bright.

It is located at the left side of the driver. By driving electric engine, the switches on the front control panel can be controlled by the driver.

**SIDE WINDOW WITH RESISTANCE**

When the movable glass is broken or when the electric motor fails, apply to the authorized service.

**WATER HEATER / COOLER FOR DRIVER (OPTIONAL)**

There is a water heater/cooler available for driver at the rightside of the driver seat. Cooling mode is at the range of 22°C below the ambient temperature; and the heating mode is at the range of up to 60 °C beverage temperature.

## CAMERA SYSTEM

The vehicle is equipped with interior and exterior cameras to record every action taken inside and around.

### External Camera System (Optional)

There are 2 external cameras beside right and left rearview mirrors in order to see the barriers around during the movement of the vehicle. The camera at right also helps to follow the getting off the passengers from the middle or back doors.

### Internal Camera System (Optional)

HAC-HMW3200LP-0210B  
2MP HDCVI IR Eyeball Mobil Kamera



There are cameras inside the vehicle 3 of which is used for controlling the entry and exit of the passengers, and one each for watching the driver and the road. The sights obtained from the camera are monitored on the LCD display on the front control panel.

## REAR VIEW SYSTEM

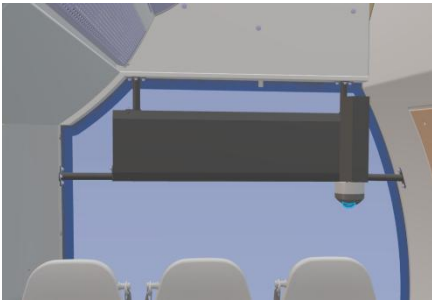

There is a closed-circuit camera system available which monitors the area behind the vehicle when parking or reversing the vehicle. The sights obtained from the camera are monitored on the LCD display on the front control panel.

## LCD DISPLAY

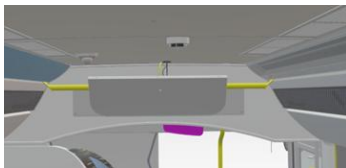

There is one 29" LCD display at the front side of vehicle. This screen may be used for informing passengers and for ad impressions.



## DESTINATION INDICATOR

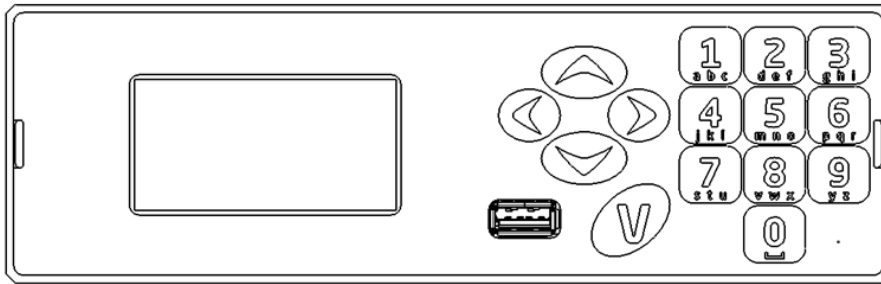

The destination indicator panel is for setting the destination display at the driver's seat.

For details on the destination display, refer to the instruction manual of the device manufacturer.

### NOTE

1. Auto-screen dimming to reduce driver glare and prolong unit life. The dimming feature activates automatically a few seconds after the unit has been left idle.
2. Highlighting of selected function helps the operator to select the required option with ease.
3. 8Mb internal flash memory ensuring it is capable of meeting the future requirements of the transport industry, with the ability to store large lists alongside complex firmware.
4. Internal piezo sounder.

## INFOTAINMENT DISPLAY SYSTEM

The infotainment display system installed in our vehicles provides passengers with real-time travel information and entertainment features. The system's screens display route details, upcoming stops, and other essential journey information, ensuring that passengers are always informed throughout their trip. In addition to practical travel data, the system can also present announcements, multimedia content, and service updates, enhancing the overall passenger experience and making each journey more comfortable and engaging.

## USB LOCATIONS OF INFOTAINMENT DISPLAY AND DESTINATION PANEL

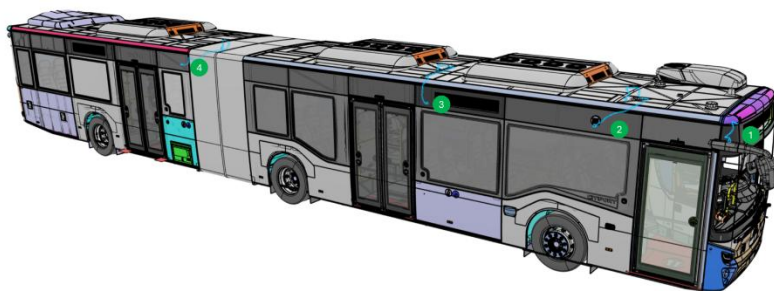

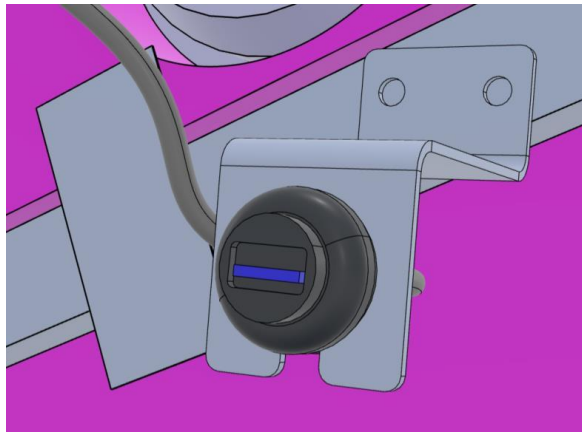
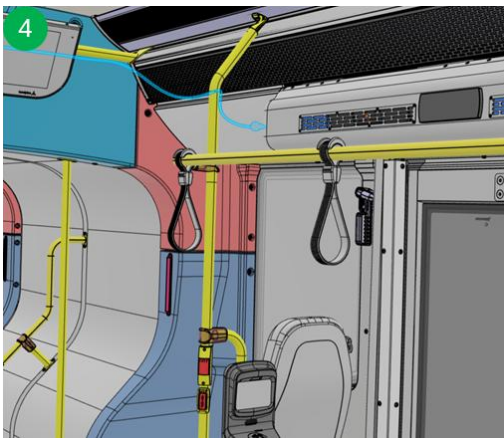
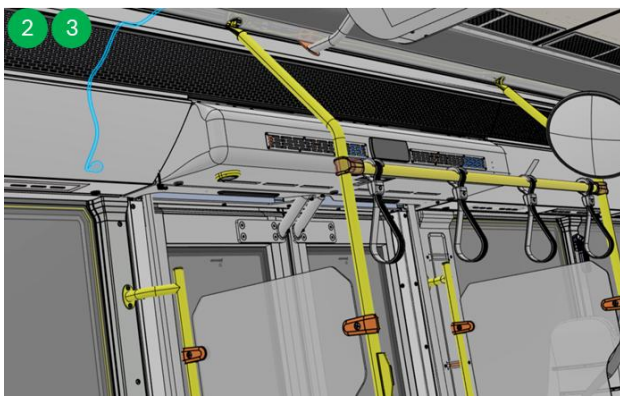
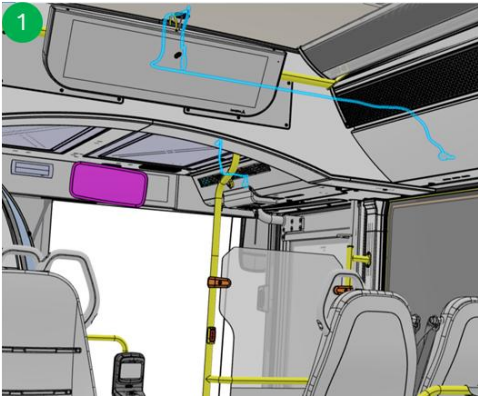

## AMPLIFIER

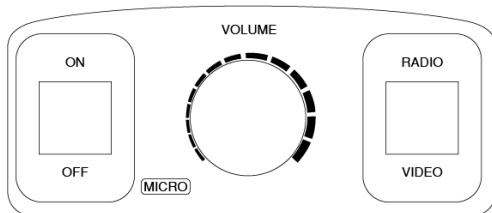

The amplifier can be used for broadcasting indoor.

The amplifier can be used when the starter switch is in the "ACC" or "ON" position.

**CAMERA SYSTEMS**

The vehicle is equipped with interior and exterior cameras to record every action taken inside and around.

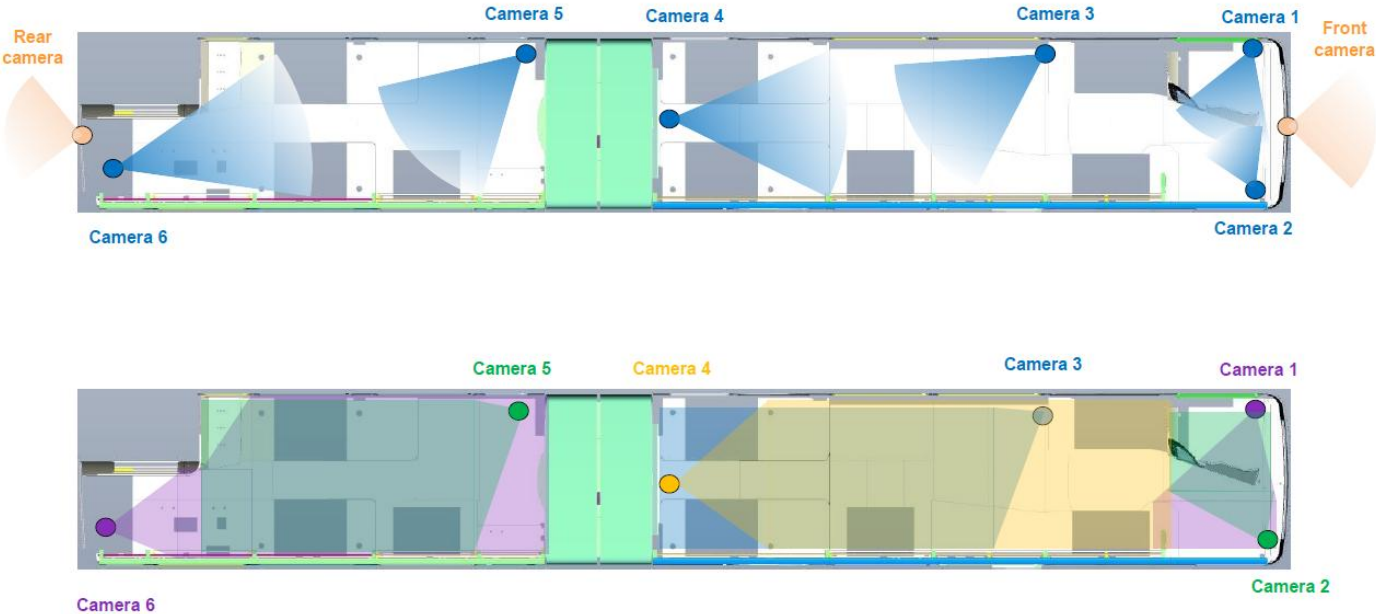

## ENGINE ROOM FIRE EXTINGUISHING SYSTEM AND CONTROL UNIT (FOGMAKER)

-Red motor fire symbol/red lamp flashes red.

-Alarm siren gives repeating acoustic signal.

Fire alarm signal – bus manufacturer's system:

See bus manufacturer's manual.

\* Do not start the vehicle until the cause of the fire has been established and rectified!

- Clean up the engine compartment as soon as possible to prevent corrosion on metal parts and unwanted flash-overs in the electrical system. Hose down with water, preferably at high-pressure. Alkaline washing agents can be used. See also the manufacturer's recommendations for washing the engine compartment.

### Engine wash after fire

Low pressure signal with fogmaker bus alarm:

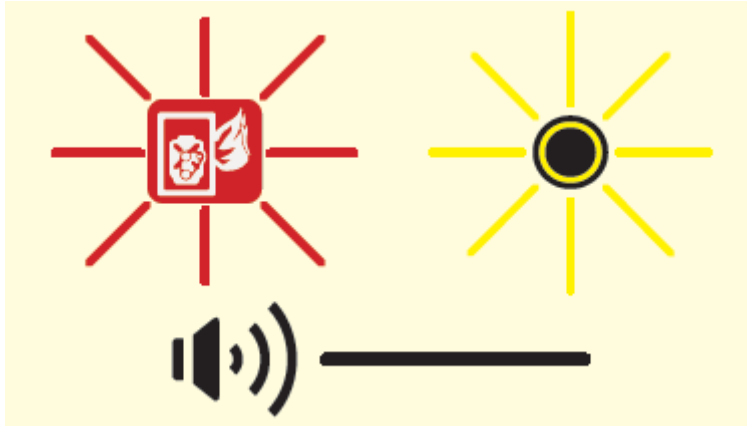

- Red engine fire symbol/yellow lamp lights constantly
  - Alarm siren sounds constantly.
  - Low pressure signal- bus manufacturer's system:
  - See bus manufacturer's manual.
- \* Contact the nearest authorized service.

### In Case Of Alarm – Fire

**Fire alarm signal - Fogmaker bus alarm:**

1		Turn off engine
2		Evacuate vehicle
3		Turn off main power
4		Call emergency services
5		Keep engine hatch closed at least 5 minutes
6		If necessary, use a hand-held extinguisher
7		Contact service personnel

**Overview, Fogmaker's Fire Protection System**

This bus fitted with a fully automatic fire protection system for the engine compartment  
The system comprises:

- Piston accumulator (1)
- Detector bottle (2)
- Pipe system with nozzles (3)
- Detector tube (4)
- Fogmaker bus alarm with acoustic and light signals or alternatively manufacturer-specific alarm panel (5)

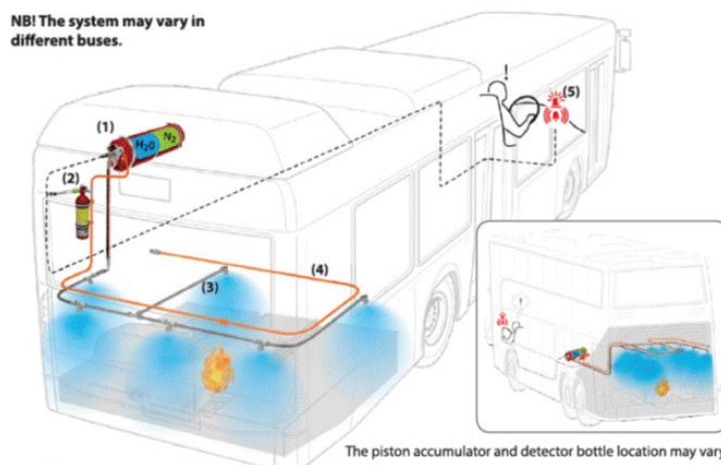

**Routine Maintenance**

Pressure switch installed: Check that lamps indicating low pressure are not alight on the bus alarm button.

Pressure switch not installed: Make sure the pressure in the piston accumulator is within the green zone on the pressure gauge.

Test the alarm before starting the day's work..

Alarm test with the Fogmaker bus alarm:

- Press down the button- two variants, see below:
- Check that there are both a sound and light signal.



Alarm test – bus manufacturer's system:  
See bus manufacturer's manual.

**Quick-guide for piston accumulator and detector bottle**

Piston accumulator: 100-105 bar at 20°C

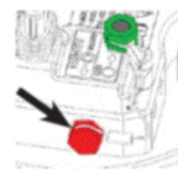

Red safety screw mounted in the side of the valve isolates the system - done before all handling

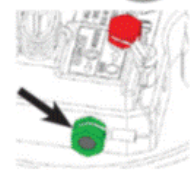

Green screw mounted in the side of the valve unlocks the system so it can deploy

Detector bottle: 20-24 bar at 20°C

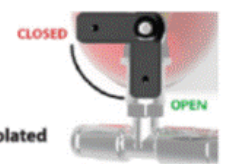

The detection system is isolated by closing the ball valve:

## TRAPDOOR



There are two covers in the vehicle, one at the front and one at the rear. The emergency exit covers are fixed and cannot be opened. They have a cover on them. After removing the cover, the glass can be broken to exit.

## HANDLES



There are handles passengers to hold. on the holding pipes in the vehicle for

## STOP BUTTON

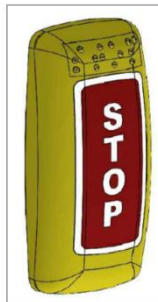

The passengers who want to get off the vehicle, informs the driver by pressing on these buttons. The related door button lights and the “STOP” expression is seen on the passenger information panel. Additionally, audible warning activates. When doors are opened, “STOP” article and the warning lights on door buttons turn off.

**SMOKE DETECTORS**

This system is designed to detect changes in heat and smoke within the environment to provide early warning of potential hazards. The heat sensor measures the ambient temperature and triggers an alarm in accordance with EN54-5 BS standards when the temperature exceeds a defined threshold. The smoke sensor detects scattered light caused by airborne particles in the air and activates an alarm according to EN54-7 standards.

**LED color indications**

- **Green:** In Operation
- **Yellow (low flashing):** Low Contamination
- **Yellow (high flashing):** High Contamination
- **Red (continuously):** Smoke Alarm
- **Red (flashing):** Heat Alarm
- **Purple:** Alarm Input Failure
- **No Color:** Power Off

When high heat or smoke is detected, the 24V output is automatically shut down. In addition, if any connection between sensors is lost, the system's LED indicator flashes or remains steadily red, depending on the type of alarm or fault condition, to alert the user.

**LOCATIONS OF SMOKE DETECTORS ON THE VEHICLE**

1. ITS ZONE
2. PASSENGER AREA 1
3. FRONT INSURANCE ZONE
4. PASSENGER AREA 2
5. MIDDLE INSURANCE AREA 1
6. MIDDLE INSURANCE AREA 2
7. ITS BATTERY AREA
8. BATTERY AREA
9. PASSENGER AREA 3
10. REAR INSURANCE AREA 1
11. REAR INSURANCE AREA 2

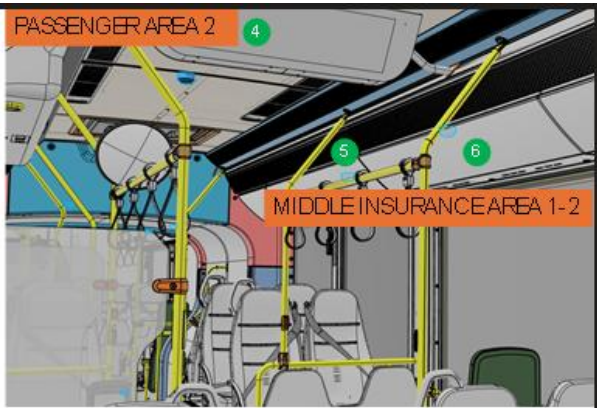
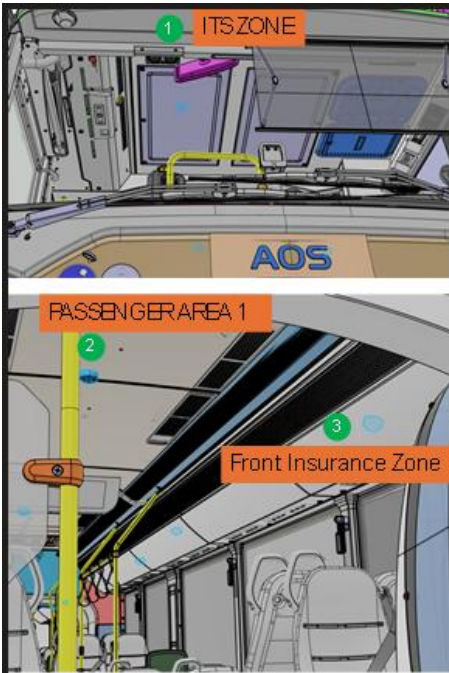
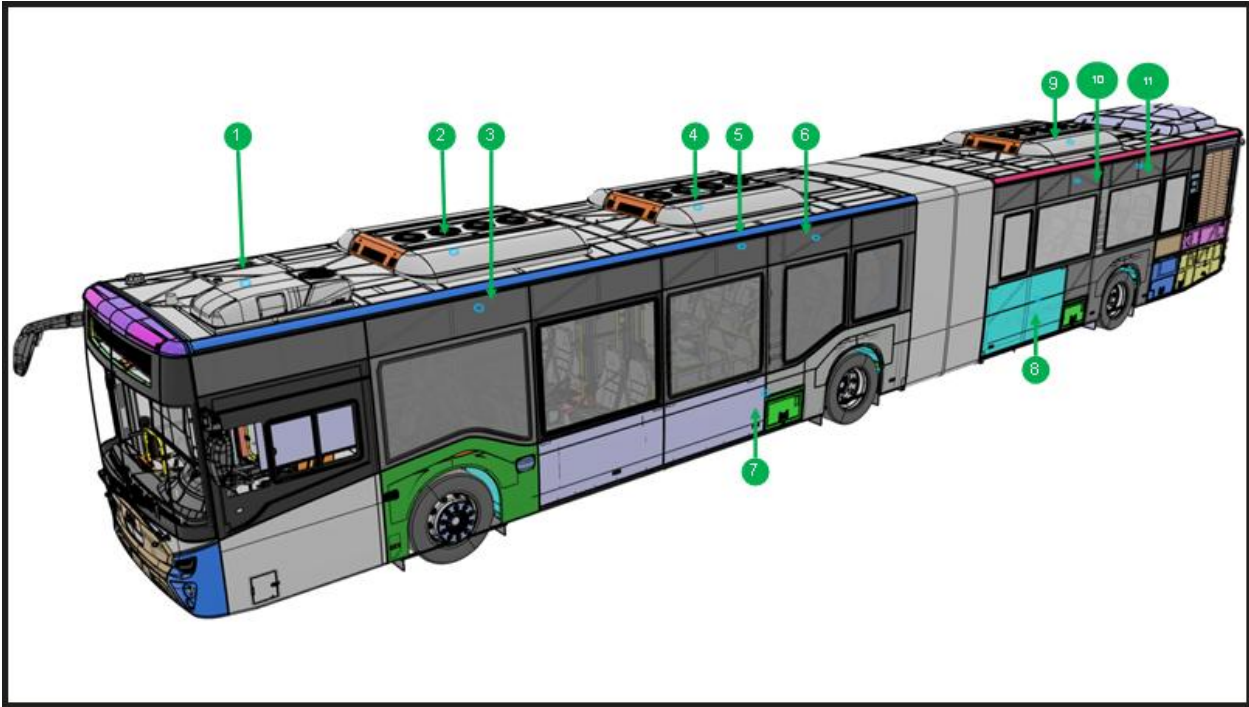

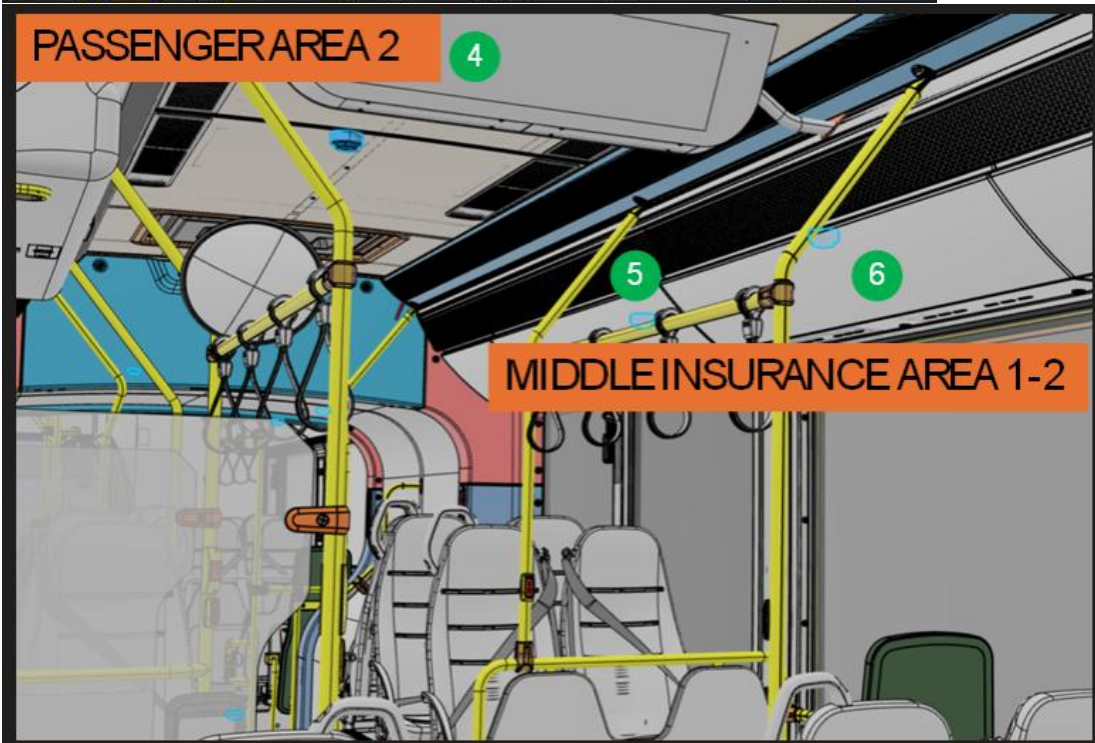
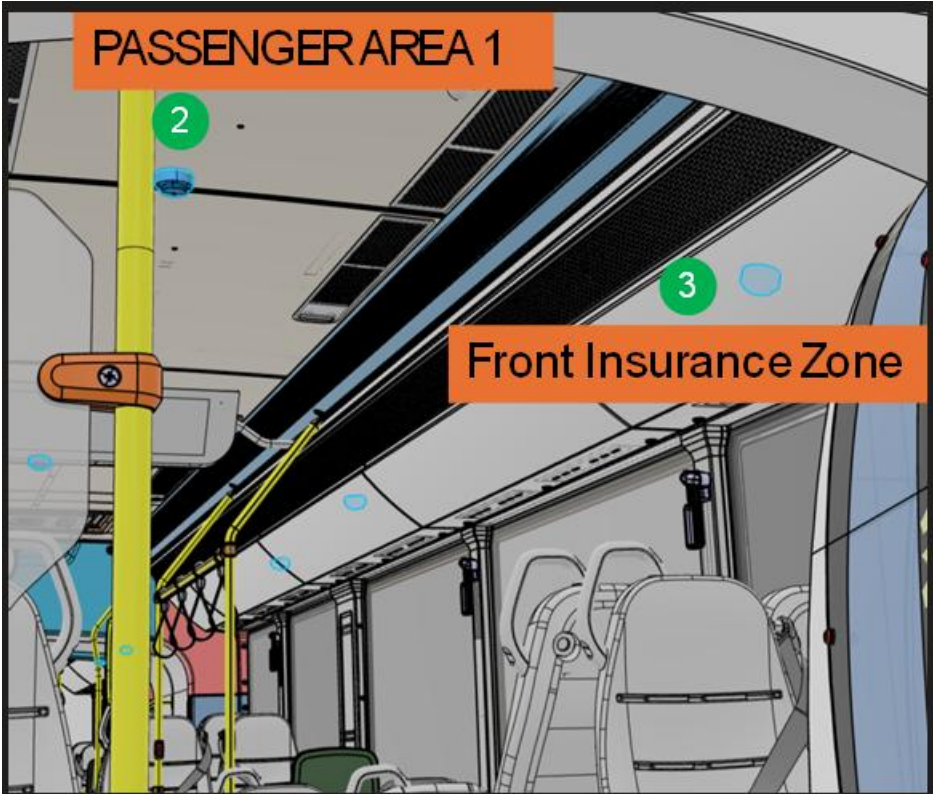

**ITS BATTERY AREA**

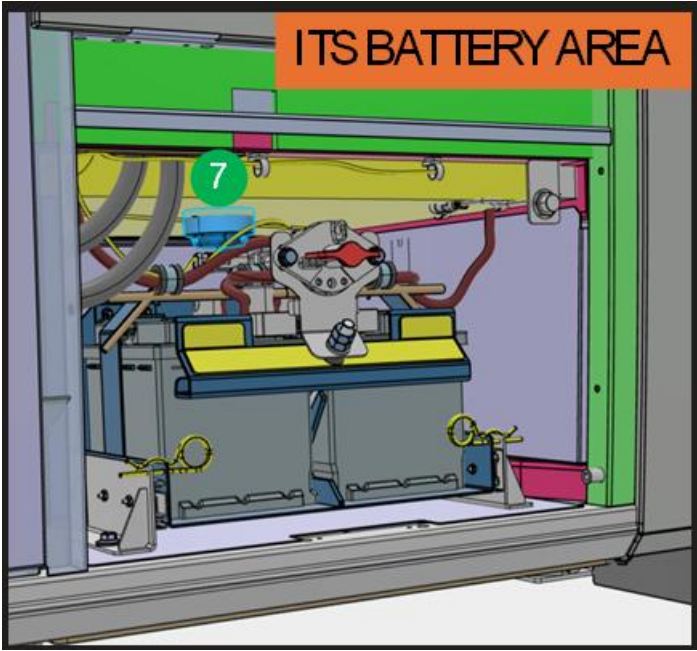

**BATTERY AREA**

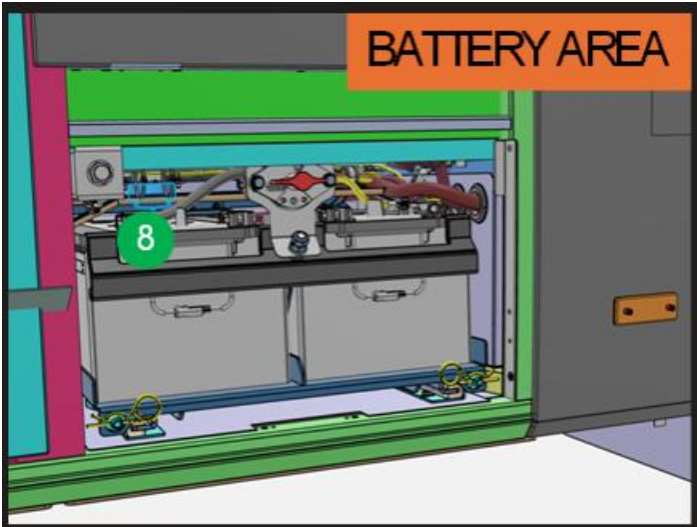

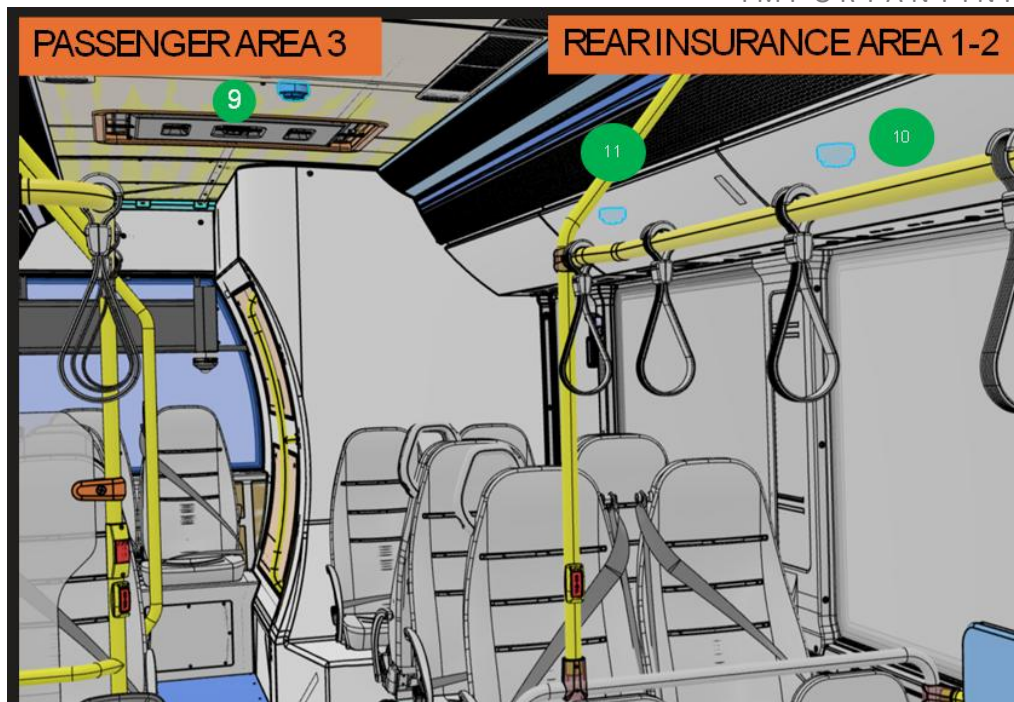

## INFRARED SENSOR

This bus is equipped with intelligent infrared sensors to maximize safety. Sensors installed above each of the three doors continuously monitor a designated area and automatically prevent the doors from closing if a person, animal, or any obstacle is detected.

The system not only ensures door safety but also halts the vehicle's movement, preventing potential accidents during passenger boarding and alighting. This guarantees that both passengers and the vehicle can travel safely and securely at all times.

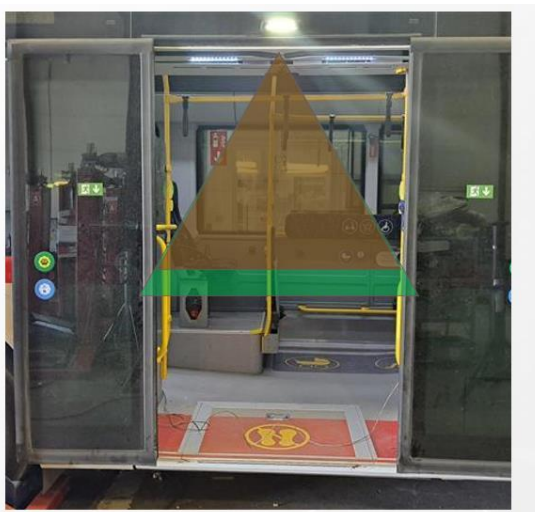
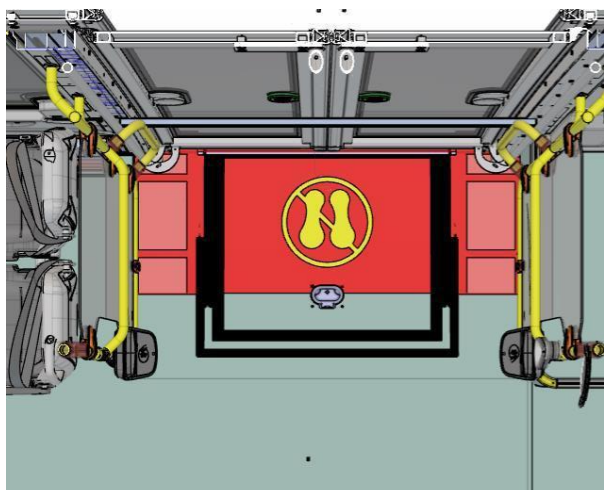

## HIDDEN DOOR RELEASE BUTTON



The vehicle is equipped with a hidden door release button located near the front, first door area. When pressed, this button activates the door mechanism and opens the door, even if the vehicle is in sleep.

This feature is designed to provide emergency access or maintenance functionality, allowing authorized personnel to open the door when the main vehicle systems are inactive.

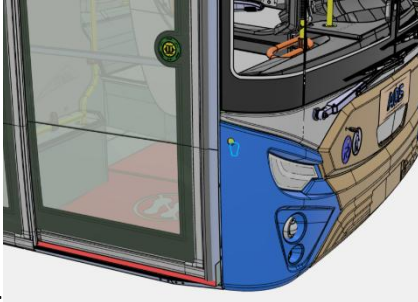

## ENGINE START/STOP BUTTON



The vehicle is equipped with an engine start button independent of the ignition switch, located at the rear section of the vehicle. When pressed, this button starts the engine directly, allowing maintenance personnel to perform inspections or servicing without using the main ignition key. This feature provides convenient access for technical operations, especially during maintenance or diagnostic procedures carried out at the rear of the vehicle.

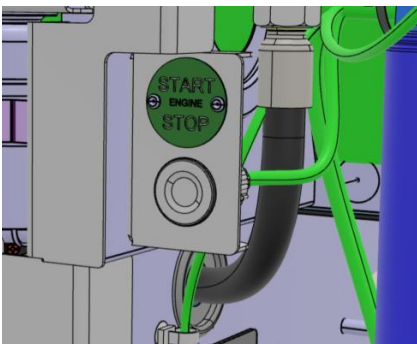

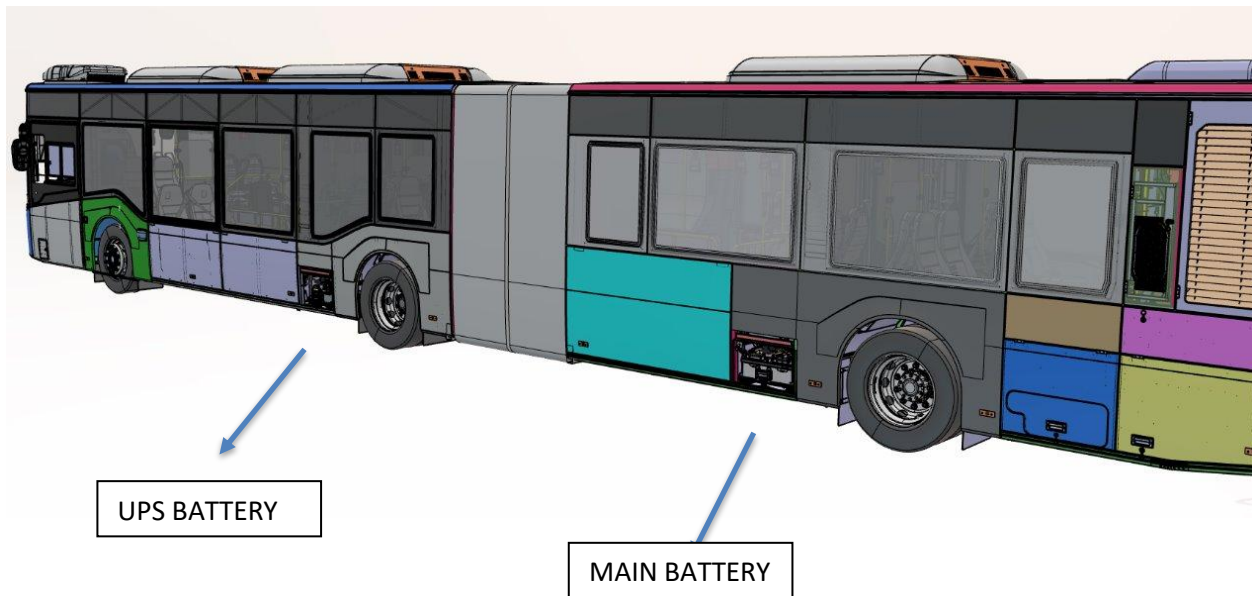
**BATTERIES, UPS AND MAIN BATTERY****1. UPS Batteries ON, Ignition ON**

→ The system will remain continuously powered.

**2. UPS Batteries OFF, Ignition ON**

→ The buzzer will activate every 10 seconds.

→ The system will remain continuously powered.

**3. Ignition OFF, UPS Batteries ON, Vehicle Batteries ON, Emergency Switch OFF**

→ The system will remain powered for 30 minutes.

→ The buzzer will activate every 30 seconds.

**4. (Ignition OFF AND UPS Batteries OFF) OR Vehicle Batteries OFF OR Emergency SW ON**

→ The system will remain powered for 30 minutes.

→ The buzzer will activate every 10 seconds.

**BATTERIES BUZZER LOACATION**

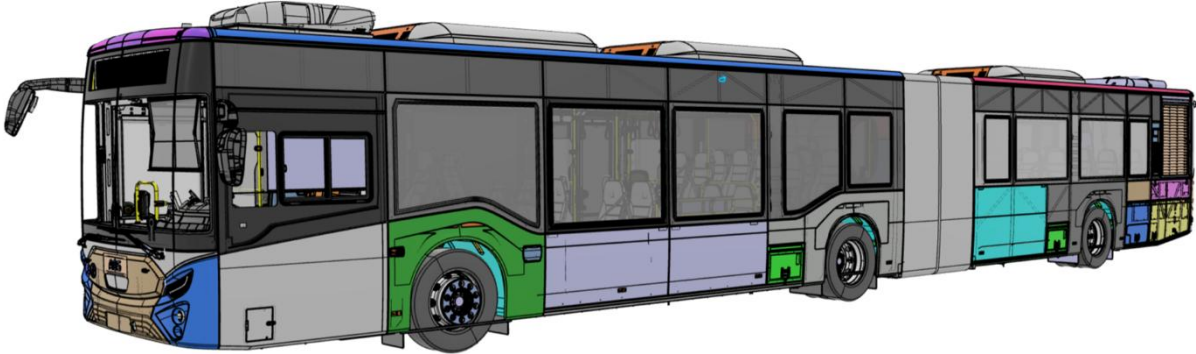

## DOOR SYSTEM CALIBRATION

### Dubai Ventura Door Calibration

- Parking brake must be engaged.
- Headlight flasher lever must be active.
- Mirror heating button must be pressed.

When these conditions are met, the doors will open and close automatically to perform the calibration.

When door control is enabled by the driver:

a. If the vehicle is stationary:

- Passenger door open buttons (inside and outside the bus) can open Door 3.
- Door 3 closes automatically if the infrared sensor does not detect any object for 10 seconds.

b. If the vehicle is moving:

- Passenger door open buttons (inside and outside) do not open Door 3 until the vehicle comes to a complete stop.
- Once the vehicle stops, Door 3 opens automatically. The driver can disable passenger control at any time.

## ARTICULATION SYSTEM

The Articulation Control Unit (ACU4) has two separate power signals: ignition (KL15) and battery (KL30). According to the supplier's documentation, the shutdown sequence of the control unit must follow this procedure:

- First, the ignition signal (KL15) must be turned off.
- Then, the battery supply (KL30) must remain active for at least 10 seconds after KL15 is turned off.
- After 10 seconds, the battery supply (KL30) can be turned off.

Warning: Failure to follow this shutdown procedure will result in an "unexpected shutdown" error in the articulation controller. In this case, the controller will not function properly. To restore functionality, the controller must be connected to the diagnostic CAN line and the errors must be cleared using the Hubner Diagnostic software.

When this error occurs, the main cluster screen will display a popup warning: "Articulation System Error! Please go to the nearest service."

Additionally, the cluster diagnostic page will show:

"ACU4 Communication Error"



## 1. MAGNETIC DOOR LOCK BUTTON

- When the ignition is on, the driver's seat is occupied, and the parking brake is released, the magnetic door lock engages (locks).
- When the parking brake is applied and the driver's seat is unoccupied, the magnetic door lock disengages (releases).
- Pressing the magnetic door button releases the magnetic lock for 5 seconds, regardless of the current conditions.

## 2. PANIC BUTTON

The system communicates emergency status data to the camera recording unit and forwards it to the onboard computer through the ITS systems interface

## 3. CLEANING BUTTON

When the Cleaning button is activated, the ceiling lights stay illuminated for 20 minutes, ensuring optimal visibility during maintenance. The lights cannot be turned off manually by pressing the button again.

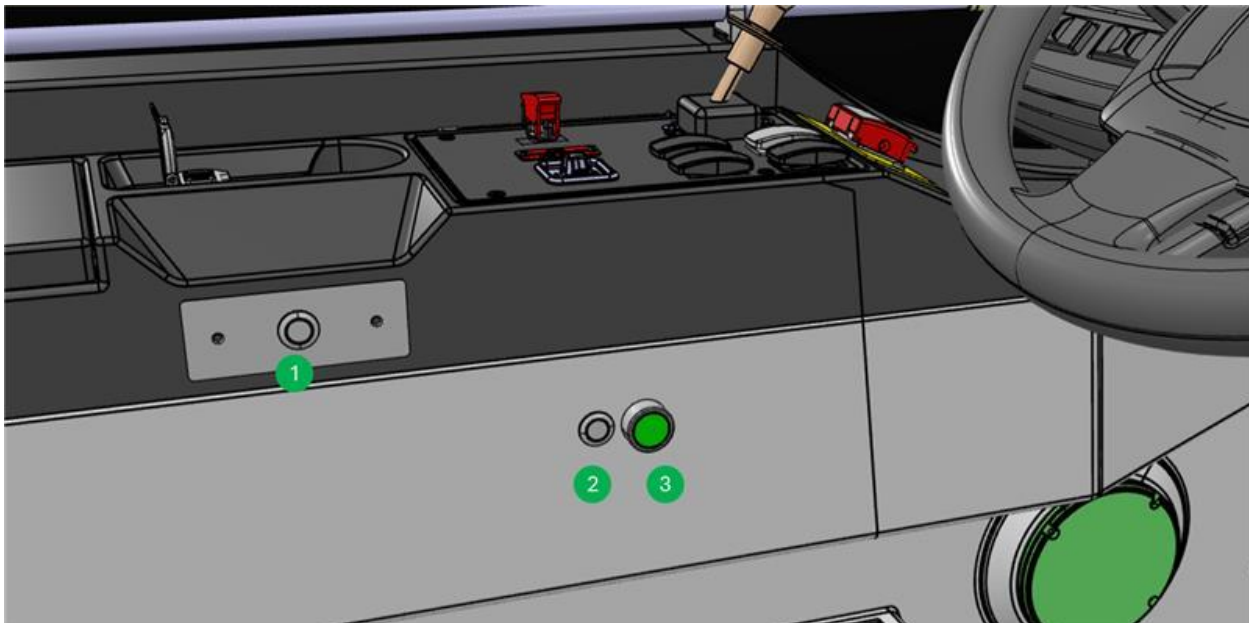

## NATO CONNECTOR

The NATO socket provides access to the bus's battery power system and serves as a standardized power connection interface.

Through this connector:

- Battery-to-battery energy transfer (jump start) can be performed between vehicles,
- The vehicle can be powered by an external power source, or
- The vehicle's electrical power can be supplied to external systems such as maintenance equipment, diagnostic tools, or auxiliary devices.

The NATO socket is compatible with 24 V DC electrical systems and ensures safe and standardized power transfer in all operating conditions.

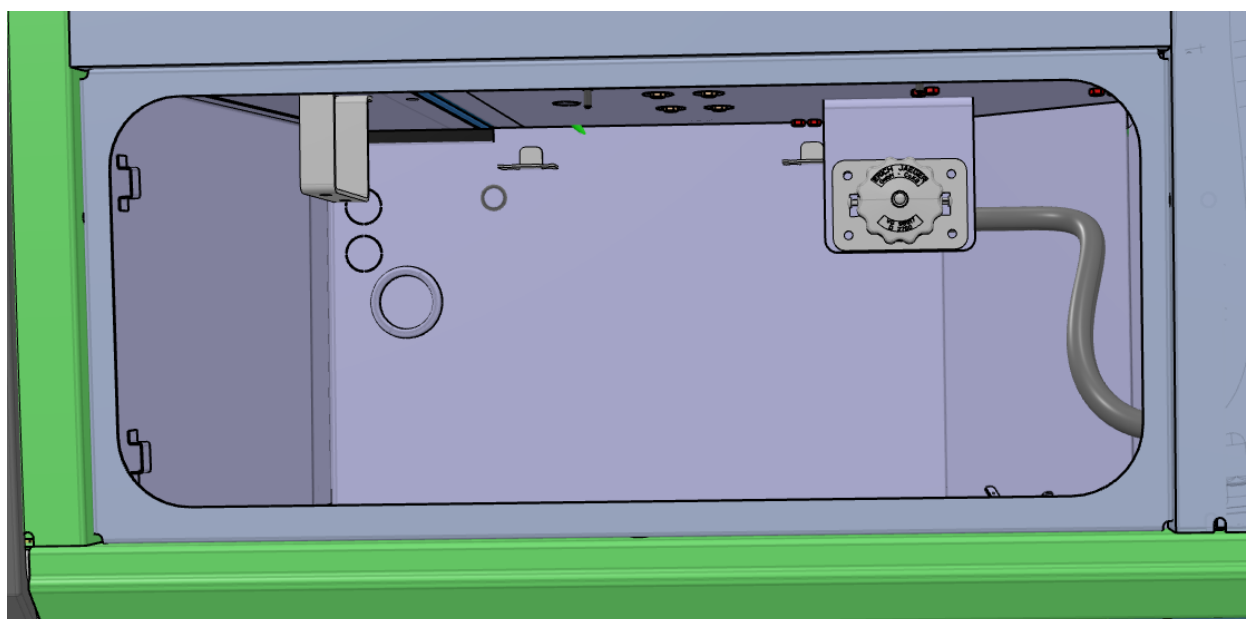

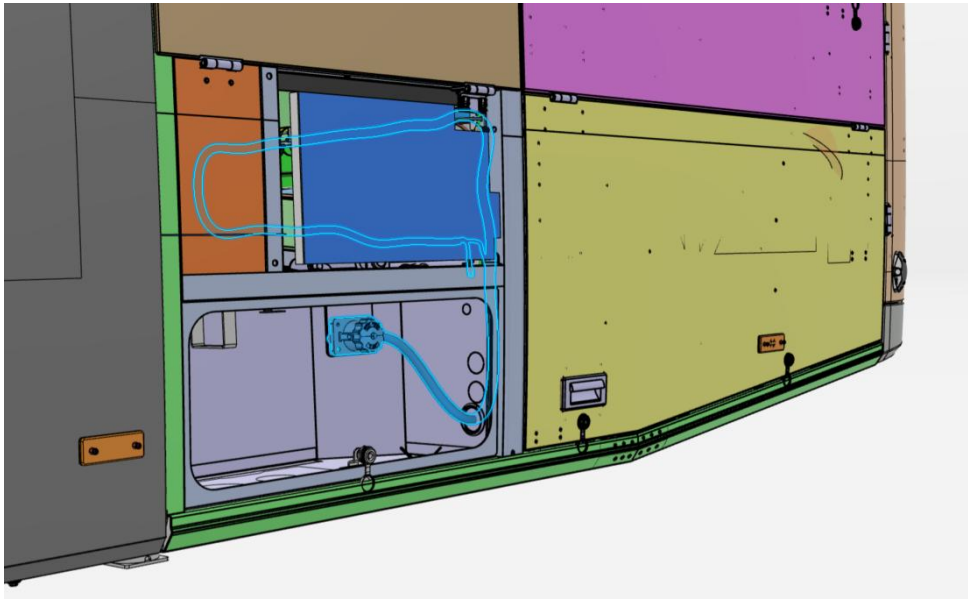

### Inductive Sensor

The device detects changes in the electromagnetic field caused by the presence of metallic targets within its sensing range. Featuring a **Normally Open (NO)** output configuration, the sensor closes the output circuit when an object is detected, transmitting a clear and reliable signal to the connected control unit. This ensures stable operation in feedback and safety circuits.

Sensors out for its high switching repeatability, electromagnetic stability, and maintenance-free operation. Its compact form factor allows for easy integration in confined spaces, while Leuze's strict quality standards ensure long-term system reliability and performance consistency.

### LOCATIONS OF SENSORS ON THE VEHICLE

1. ITS BATTERY AREA
2. MAIN BATTERY AREA
3. ENGINE AREA 1
4. ENGINE AREA 2



1. ITS BATTERY AREA
2. BATTERY AREA
3. ENGINE AREA
4. ENGINE AREA

## Driver Monitoring System (DMS)

It is installed in the car to provide the driver with real-time driving assistant information display, combined with sound reminding and warning.

### LOCATION ON THE VEHICLE

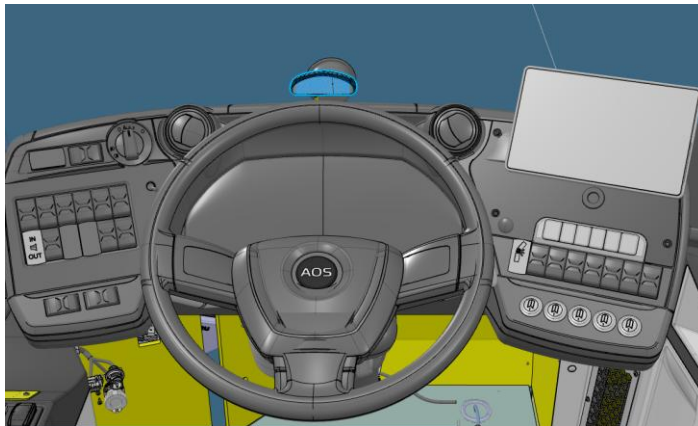







### • DMS ICON MEANING

	<p><b>Driver Fatigue Warning</b> Indicates that driver fatigue occurs during driving.</p>
	<p><b>Hand Phone Warning</b> Indicates that driver is using hand phone.</p>
	<p><b>Driver Smoking Warning</b> Indicates that driver is smoking.</p>
	<p><b>Driver Distraction Warning</b> Indicates that driver is distracted.</p>
	<p><b>No Driver Warning</b> It means that the driver left the driver's seat or deviated from his seat too far.</p>

- OPTINAL ICONS

	<p><b>Headway Distance Meter</b></p> <p>A two-digit number that reflects the headway, in seconds, from the vehicle ahead. Only values of 2.5 seconds or less are displayed. Green indicates safe headway.</p>
	<p><b>System Initialization</b></p> <p>The system is initializing.</p>
	<p><b>System Activation Indicator</b></p> <p>The system has been activated.</p>
	<p><b>System Offline Indicator</b></p> <p>The system is offline.</p>
	<p><b>Front Collision Warning</b></p> <p>Indicates possible collision with the vehicle in front.</p>
	<p><b>Multi Information Display</b></p> <p>Vehicle distance, speed limit sign (upper left corner), pedestrian collision warning (upper middle), DSM alarm (upper right corner), etc. can be displayed on the display screen simultaneously.</p>

	<p>Red indicates unsafe headway.</p>
	<p><b>Pedestrian Collision Warning</b> Indicates possible collision with pedestrian.</p>
	<p><b>Pedestrians in the Danger Zone</b> A pedestrians have been detected in the "danger zone"; time to collision is not critical.</p>
	
	<p><b>Left/Right Deviation Alert</b> The left or right deviation indicator will flash for 1 seconds when the vehicle unintentionally departs from the driving lane.</p>
	<p><b>Speed Limit Indicator</b> The detected speed limit signs are displayed in the form of large icons.</p>

## OBD SYSTEM

The **OBD (On-Board Diagnostics)** system in commercial vehicles is an electronic diagnostic system that continuously monitors the engine, emissions, and other critical components of the vehicle, detecting and recording any malfunctions.

### LOCATIONS ON THE VEHICLE

1. DRIVER'S AREA
2. ITS AREA
3. REAR DOOR AREA

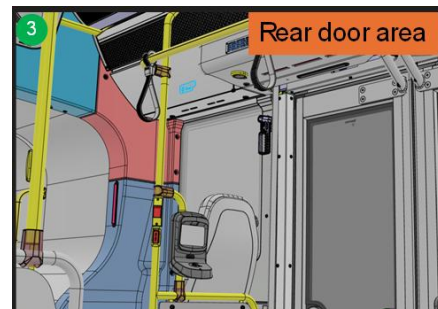
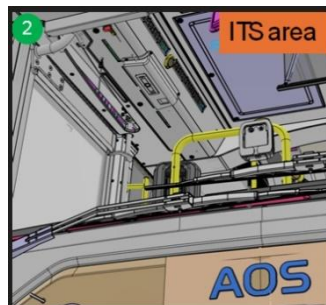
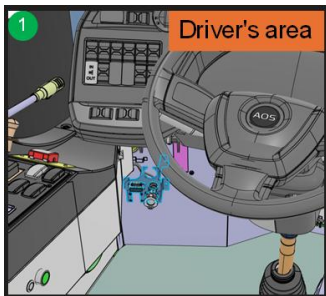

USB SYSTEM

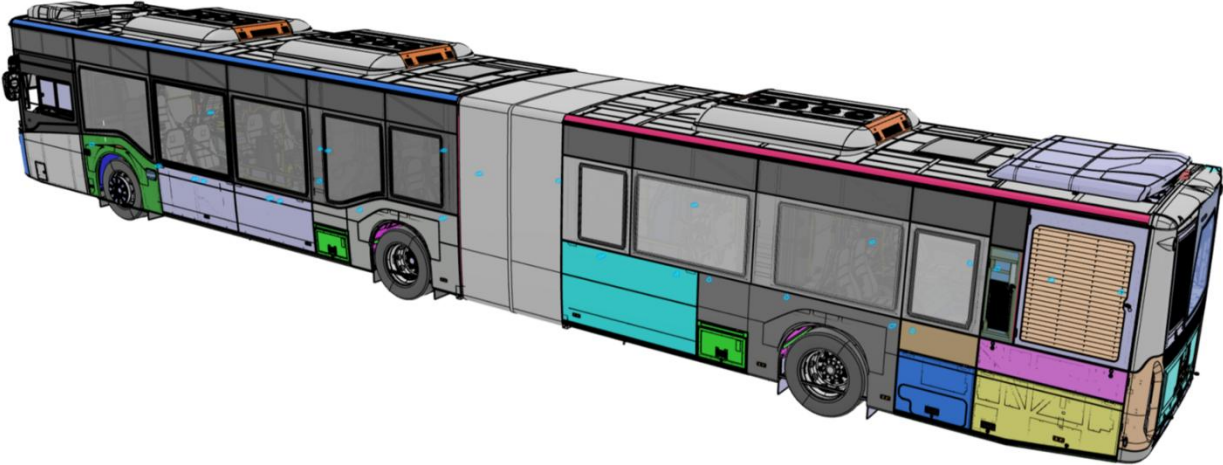

Left Front Area

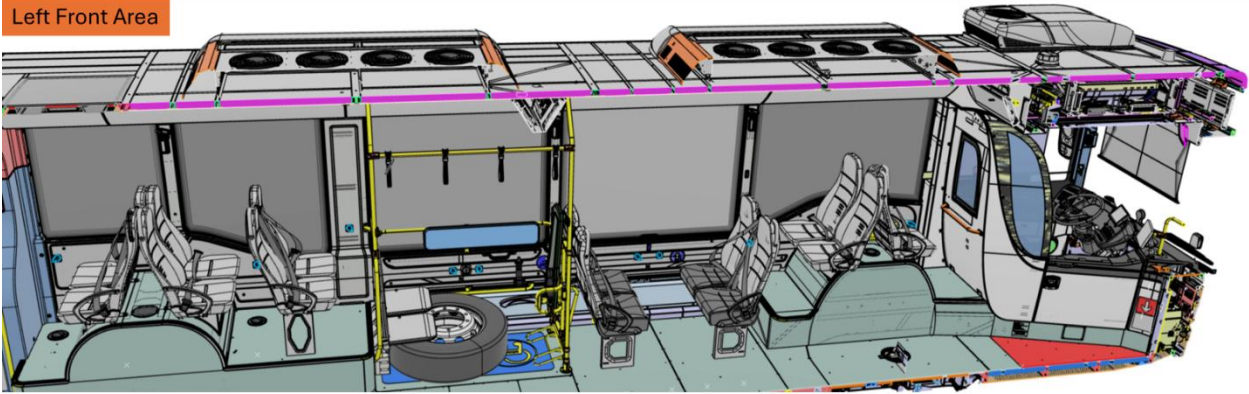

Left Rear Area

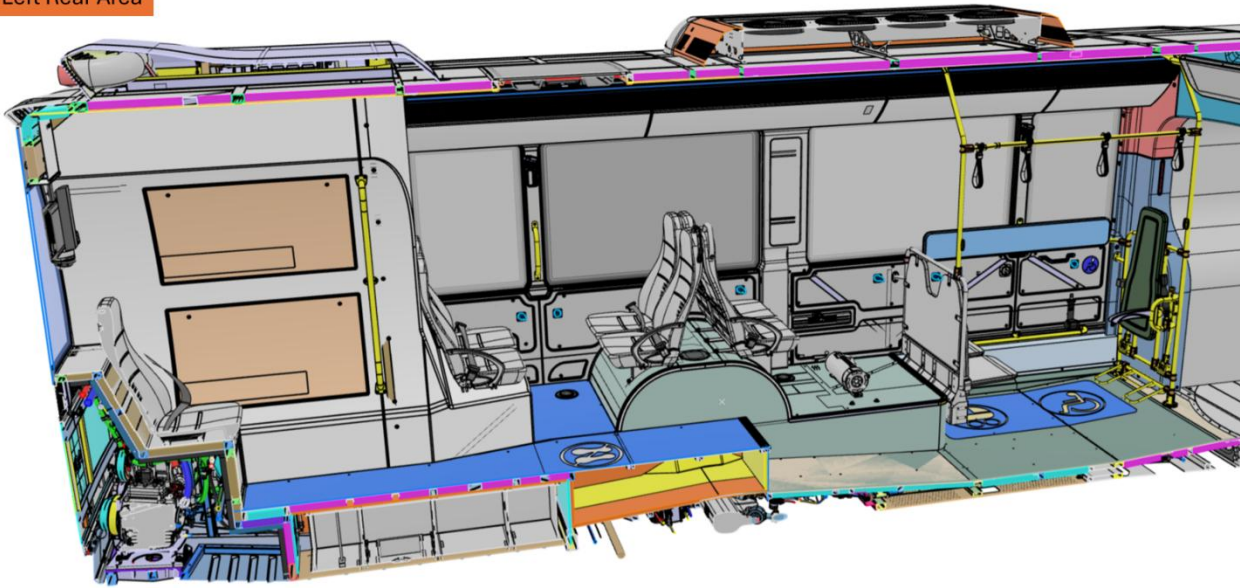

Right Front Area

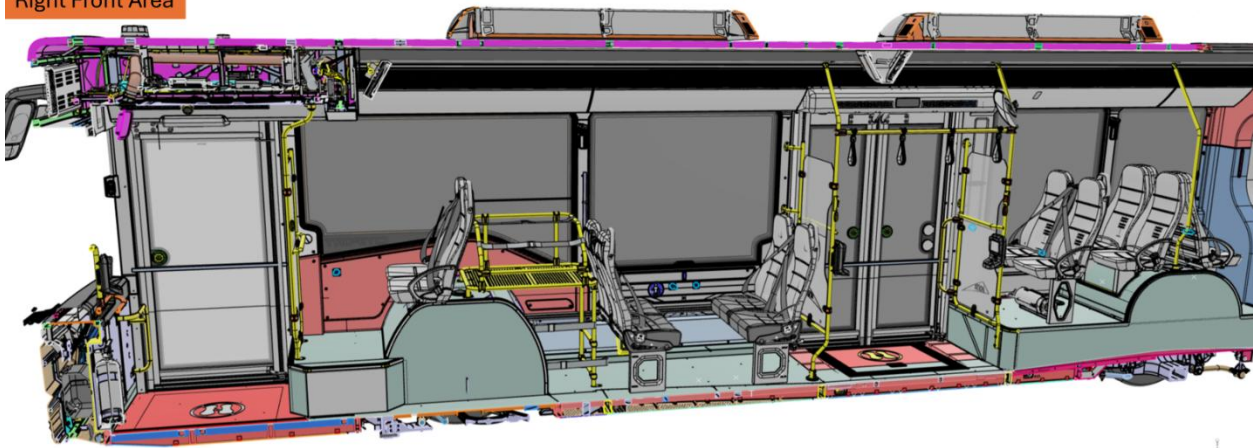

Right Rear Area

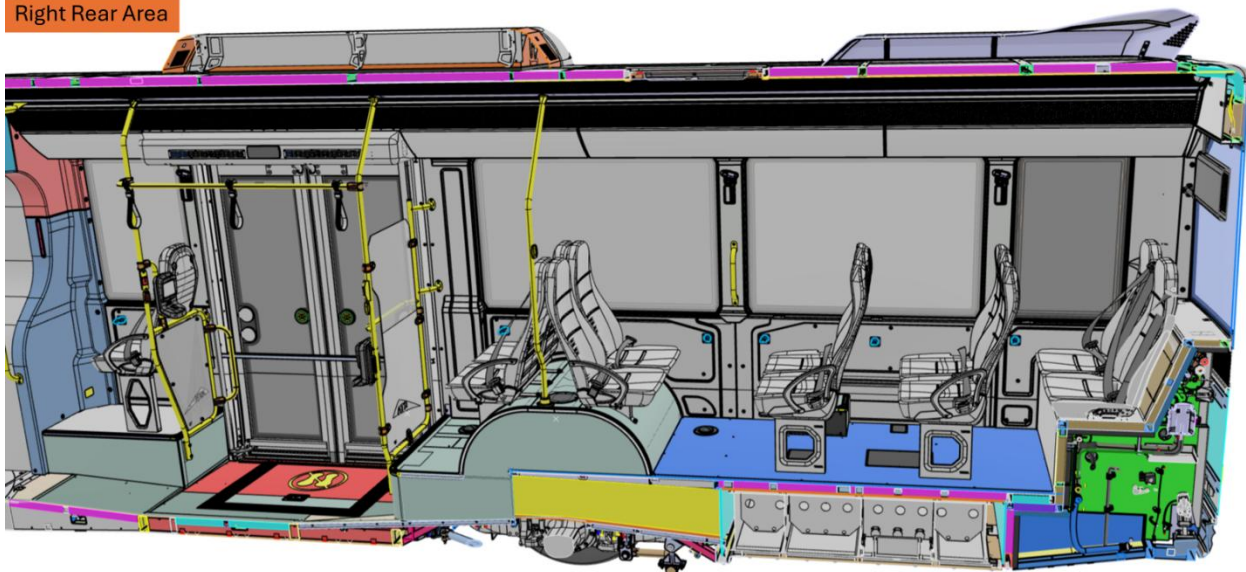

### REGENERATIVE BUTTON

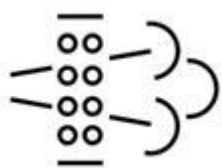

The **REGEN button** is used to initiate the **DPF (Diesel Particulate Filter) regeneration** process. Over time, soot and particles from exhaust gases accumulate in the filter, causing it to become clogged. When this button is pressed, the exhaust temperature increases, burning off the accumulated soot and cleaning the filter.

### Door Control Button Light



When door opening is not permitted, the button light remains off (colorless). When the driver grants permission, the button light turns green. If the button is pressed while the doors are closed, the button light turns red, indicating that door opening is not allowed while the vehicle is in motion. When the vehicle is in park mode and the button is pressed, the door opens and the button light turns green.

In addition, all stop buttons in the vehicle are illuminated when the park mode is active



## CONTROLS AND INSTRUMENTS

## STARTING AND STOPPING THE ENGINE

## STARTING THE ENGINE

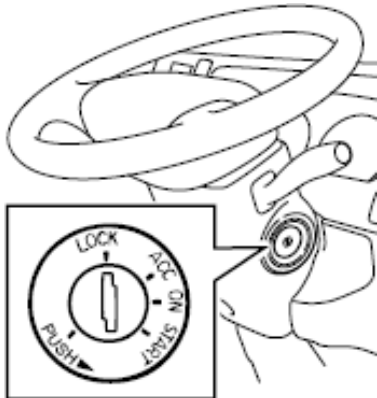

Make sure that the switches, including those for the windshield wiper, light control and air conditioner, are in the off position.

Turn the starter switch to the "ON" position to check that the warning and indicator lights turn on normally and the fuel level is proper.

## CAUTION

- When the engine does not start, wait for at least 2 seconds and then turn the starter switch again.

1. Make sure that the gearshift switch is in the "N" position and firmly press the brake pedal.
2. When the starter switch is turned to the "ON" position, the glow plug indicator light comes on and it goes out in about 0.5 seconds when the engine is warm, or in about 4 seconds when the engine is cold.
3. After confirming that the glow plug indicator light has gone out, turn the starter switch to the "START" position to start the engine.

## WARNING

- Do not keep the starter switch in the "START" position for more than about 10 seconds. Operating the starter for too long might cause battery failure or might result in overheating and even a fire.

## STOPPING THE ENGINE



Firmly apply the parking brake. With the accelerator pedal released, turn the starter switch to the "ACC" or "LOCK" position.

## ADVICE

- Do not shut down the engine immediately after driving the vehicle. Otherwise, a seizure or other failures may result. Before stopping the engine, run the engine at idle for approximately 3 minutes to cool it down after applying the parking brake and making sure of the following: The gearshift switch is in the "N" position and the shift indicator shows "N".
- To prevent the battery from going dead, turn the starter switch to the "ACC" or "LOCK" position after stopping the engine. If you leave the vehicle for an extended period of time, place the starter switch in the "LOCK" position.

## INSTRUMENTS, WARNING LIGHTS AND INDICATOR LIGHTS

### INSTRUMENTS LAYOUT

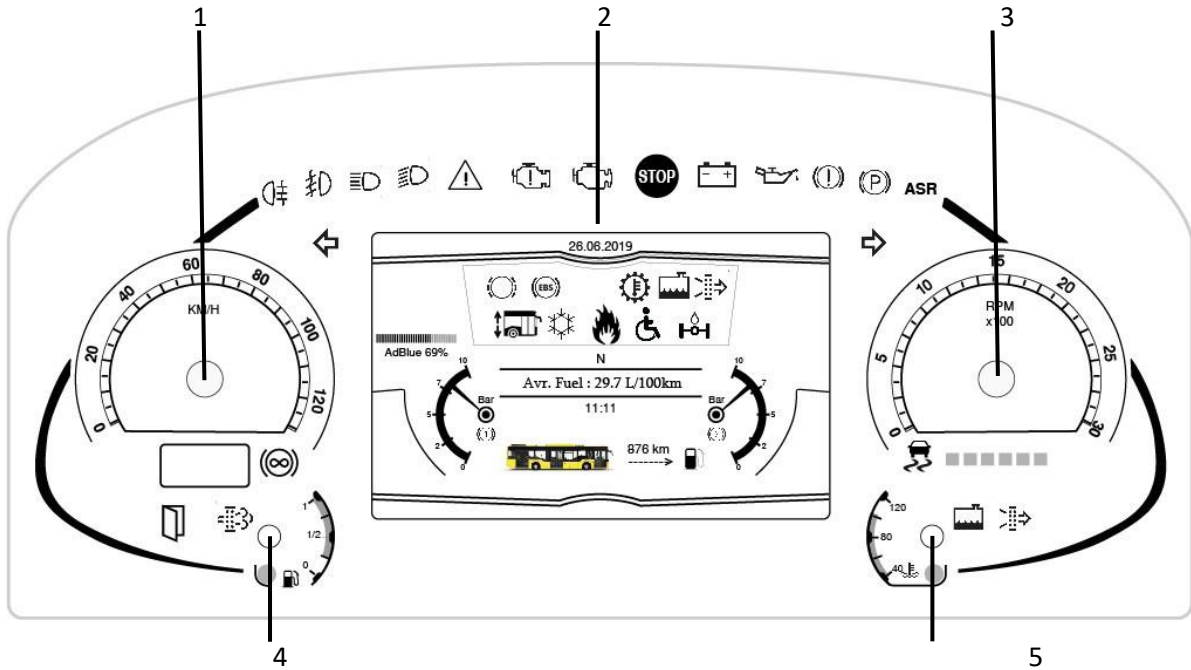

No.	Name
1	Speedometer
2	Multi-Information Display (MID)
3	Tachometer

No.	Name
4	Fuel gauge
5	Engine coolant temperature gauge

### SPEEDOMETER

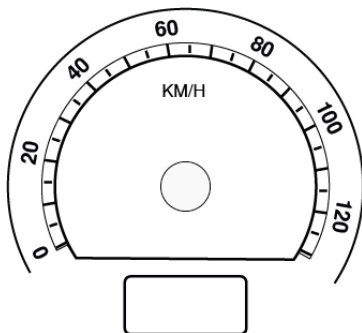

The speedometer indicates the vehicle speed in km/h or MPH. The speedometer is an integral unit with the odometer/trip meter.

The total distance traveled by your vehicle is indicated in km if the speedometer is graduated in kilometer units.

Use the trip meter to learn the distance between the specific points or the distance traveled during a specific period of time.

## MULTI-INFORMATION DISPLAY (MID)

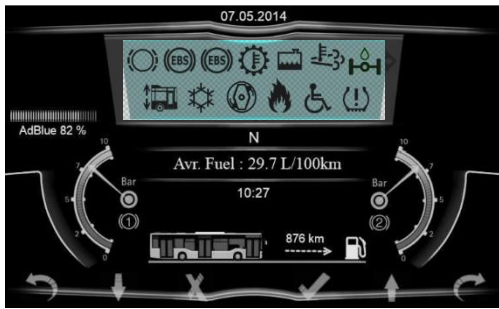

The MID in the instrument panel can display the following information.

- Warning and indicator lights
- Operation-related information
- Brake pressure
- Maintenance data
- Urea® level
- Calendar and clock



**Lining Pad Warning:** It is the yellow colored warning which lights when the percentage of lining thickness coming from EBS decreases below 10%.



**EBS Warning:** It is the red or yellow colored warning which lights when a failure datum came from EBS module.



**Transmission Heat Warning:** It is the yellow colored warning which lights when the transmission oil is more than 107 °C.



**Air Condition Is Active Warning:** It is the blue colored warning which lights after 2 minutes from the activation of the air condition.



**Fire Warning:** It is the red colored and audible warning which lights when the temperature of the engine room exceeds 175 °C.



**Stop Warning for Disabled Passengers:** It lights when pressed stop button for disabled passengers.



**Tire Pressure Warning:** It is the yellow colored warning which lights when the tire pressure is not between 123 – 138 psi. In case of rapid tire pressure losses red STOP light will appear.

---

## TACHOMETER

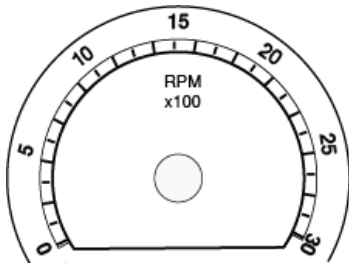

The tachometer indicates the engine speed in revolutions per minute (r/min). (Graduation "5" on the scale indicates 500 r/min.) The red zone indicates a range of dangerous engine speeds beyond permissible levels. Do not drive your vehicle with the needle of the tachometer in the red zone. The graduation and the red zone of tachometer are various depending on the models fitted.

## ADVICE

- Exercise extreme caution when shifting down on a steep downslope. The engine speed may easily exceed the critical speed, which can seriously damage the engine.

---

## FUEL GAUGE

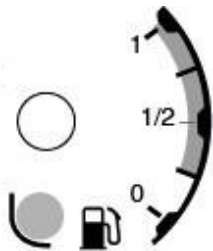

With the starter switch in the "ON" position, this gauge indicates the quantity of fuel remaining in the fuel tank. "1" means the tank is full while "0" means the tank is almost empty.

---

## ENGINE COOLANT TEMPERATURE GAUGE

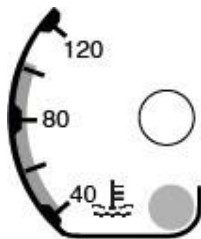

With the starter switch in the "ON" position, this gauge indicates the temperature of the engine coolant. If the engine overheats, the engine overheats warning light comes on and a warning buzzer sounds. During operation, the needle should stay in the safety zone.

## WARNING AND INDICATOR LIGHTS

### Brake System Warning Light

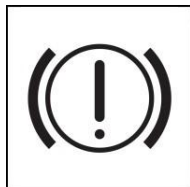

This warning light should come on when the starter switch is turned to the "ON" position, and then should go out after the engine is started.

The brake system warning light comes on while the engine is running (after startup) in the following situations:

- Drop in the level of brake fluid (due to brake wear or fluid leakage, etc.)
- Abnormality in the charging system (such as a generator malfunction or either loosening or splitting of the fan belt, etc.)
- Abnormality in the anti-lock brake system (ABS) boost assist function.

### Brake Warning Light



This warning light should come on when the starter switch is turned to the "ON" position, and then should go out after approximately 3 seconds.

This warning light comes on when the electronic braking system (EBS) has a problem.

### CAUTION

- When the brake warning light is illuminated, it signals that an EBS malfunction has occurred.
- In this case, although the feeling of the brakes will change considerably due to the in operation of the EBS, the regular brakes will still operate normally. If the EBS malfunctions, firmly depress the brake pedal, stop the vehicle, and contact your nearest Isuzu Dealer.



**Retarder Warning:** It is the yellow colored warning which lights when the retarder is active.



**Engine STOP Warning:** It is the red colored warning which lights when there is a critical engine failure, apply to the authorized service.



**Air Suction Stopped Warning:** It is the yellow colored warning which shows that the air suction is not sufficient.



**Engine Cooling Fluid Level Warning:** It is the red colored and audible warning which shows that the engine cooling fluid level decreased and it has to be added.



**Regeneration Warning:** It is the yellow colored warning which shows that the vehicle had to be taken into regeneration.

---

## ESC Warning Light



When the starter switch is turned to the "ON" position, the ESC warning light turns on before going out after approximately 3 to 5 seconds. This warning light comes on whenever there is a problem in the electronic stability control (ESC). When the ESC is operating, the ESC warning light flashes.

The ESC warning light will also flash when only the anti-slip regulator (ASR) function is operating inside the ESC system.

When the ESC warning light does any of the following, the ESC may be faulty. Please contact the nearest Isuzu Dealer.

- When the ESC warning light remains on while driving.
- The ESC warning light does not turn on when the starter switch is turned to the "ON" position.

### NOTE

- When the ESC warning light is on, the ESC/ASR will not operate, but this has no effect on normal driving.

---

## Engine Oil Pressure Warning Light



This warning light should come on when the starter switch is turned to the "ON" position, and then should go out after the engine is started.

While the engine is running, this warning light comes on if the engine oil pressure, which lubricates the engine components, is abnormal.

### ADVICE

- If this warning light comes on while the engine is running, immediately pull off to a safe place well clear of traffic. Stop the engine immediately and check the engine oil level.
- The lubrication system may be faulty. Promptly have your vehicle inspected at the nearest Isuzu Dealer.

### NOTE

- If your vehicle is equipped with MID, the check engine oil level warning light appears on the display when the engine oil level is too low.

---

### Engine Overheat Warning Light

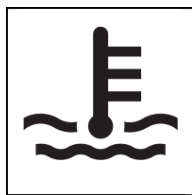

This warning light comes on when the engine has overheated. When the engine overheats, the engine coolant temperature gauge needle reaches the red zone, and the engine overheat warning light comes on, and at the same time a buzzer sounds. Immediately pull off to a safe place, and check the vehicle and take necessary actions.

#### WARNING

- Do not remove the radiator cap or reserve tank cap when the engine coolant is still hot. Careless removal could result in burns caused by hot vapor being released. Burns may also be caused by boiling water released due to the high temperature of the coolant. Perform inspection, refilling, and replacement of coolant only when its temperature has cooled.

---

### Generator Warning Light

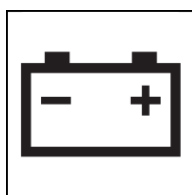

This warning light should come on when the starter switch is turned to the "ON" position, and then should go out after the engine is started.

This warning light comes on when, while the engine is running, there is a problem with the charging system (such as a loose or broken fan belt).

#### ADVICE

- If this warning light comes on while the engine is running, immediately pull off to a safe place well clear of traffic and promptly contact the nearest Isuzu Dealer for inspection.

---

### Check Engine Warning Light

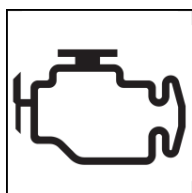

This warning light should come on when the starter switch is turned to the "ON" position, and then should go out after the engine is started.

If this warning light comes on while the engine is running, this alerts you to a problem with the engine electronic control system.

#### ADVICE

- If this warning light comes on while the engine is running, avoid driving at high speeds and promptly have the vehicle inspected at the nearest Isuzu Dealer.
- If this warning light comes on either intermittently or continuously while driving, service is required. Even if the vehicle is drivable, and does not require towing, see your Isuzu Dealer as soon as possible for service of the system. Continued driving without having the system serviced could cause damage to the emission control system. It could also affect fuel economy and drivability.

---

### Automatic Transmission Oil Temperature Warning Light

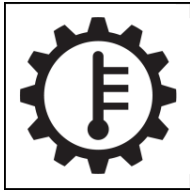

This warning light will come on when the A/T oil temperature becomes high. At the same time, the buzzer sounds.

In addition, the Smoother warning light will flash when the A/T oil temperature becomes abnormally high.

In these cases, stop the vehicle in a safe location, and place the shift lever into the "N" position to cool down the engine until the A/T oil temperature warning light goes out.

---

### Low Fuel Warning Light



This warning light comes on when the fuel level in the tank becomes too low while the engine is running.

#### ADVICE

- If the vehicle runs out of fuel, air bleeding procedure must be performed.

---

### Turn Signal and Hazard Warning Indicator Light

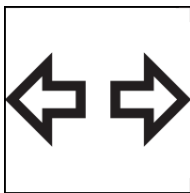

Either of these indicator lights flashes when the turn signal switch is operated with the starter switch in the "ON" position.

Both indicator lights flash when the hazard warning flasher switch is operated irrespective of the position of the starter switch.

---

### High Beam Indicator Light



This indicator light comes on when high beam is selected or the headlights are cycled between high and low beams (passing signal).

---

### Low Beam Indicator Light



This indicator light comes on when low beam is selected.

---

### Front Fog Light Indicator Light

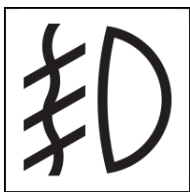

This indicator light stays on while the front fog lights are on.

---

### Rear Fog Light Indicator Light

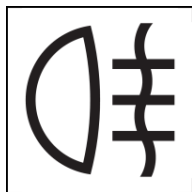

This indicator light stays on while the rear fog lights are on.

---

### Parking Brake Warning Light



This warning light comes on when the parking brake lever is pulled up.

#### CAUTION

- The illumination of the warning light does not necessarily ensure firm application of the parking brake. The parking brake lever must be sufficiently pulled up and locked.

---

### ASR Indicator Light

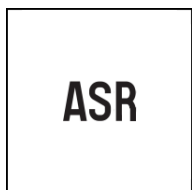

When the starter switch is turned to the "ON" position, the indicator light should come on and change color from amber to green before it goes out 2 seconds later.

This indicator light stays on green while the anti-slip regulator (ASR) is in operation.

This indicator light comes on amber if there is a problem with the ASR or when you disengage the ASR using the ASR OFF switch.

#### CAUTION

- If the ASR indicator light comes on amber while driving without operation of the ASR OFF switch, pull off to a safe place well clear of traffic and take the following actions.
  - Stop the engine.
  - Turn the starter switch to the "ON" position. The system is normal if the indicator light comes on first amber and then green before it goes out 2 seconds later. The ASR is operating satisfactorily.
- If the indicator light does not come on or go out, or comes on repeatedly, have the vehicle inspected/serviced at the nearest Isuzu Dealer as soon as possible.

---

### DPF Indicator Light



The Diesel Particulate Filter / Exhaust System Cleaning Lamp informs the operator of the filter's regeneration requirement when the engine or machine operation has not provided sufficient conditions for the particulate filter to automatically regenerate.

1. First Stage – Regeneration Requirement
- Steady ON: When the particulate filter soot load reaches a level that indicates the need for regeneration, the lamp remains steadily lit. (The lamp also comes on when a manual regeneration is initiated.)
  - Flashing (~1 Hz): When the soot load approaches a critical level, the lamp flashes at approximately 1 Hz frequency.

From the first stage of this warning, depending on the application and the desired operating scenario of the vehicle, two alternative actions are possible for the operator:

1. **Change in duty cycle:** The machine's operation cycle is modified in a way that supports regeneration of the particulate filter.
2. **Regeneration-focused operating mode:** The machine is switched to a manual-regeneration mode where the primary objective is to carry out regeneration of the filter.

### 2. Critical Level

When the particulate filter soot load reaches the critical level, the **Yellow Warning Lamp** illuminates, and in addition, the **Diesel Particulate Filter / Exhaust System Cleaning Lamp** continues flashing.



### 3. Above Critical Level

If the particulate filter soot load is allowed to exceed the critical level:

- The **Diesel Particulate Filter / Exhaust System Cleaning Lamp** turns **OFF**
- The **Red Stop Lamp** remains steadily **ON**

This indicates that the engine must be shut down, and the filter can no longer be reliably regenerated on the machine.



### HEST Lamp

When a manual regeneration is initiated, the **HEST Lamp (High Exhaust System Temperature Lamp)** comes on steadily and remains **ON** during the cleaning process.

Lettering	High Exhaust System Temp or ISO 2575 Symbol Number F.26	
	 (Option A) ISO 7000-2844	 (Option B) combination of ISO 7000-2433,2596,2844 and ISO 7000-0034
Durability	SAE Recommended Practice J1211	
Visibility	Easily Identifiable and clearly visible to the operator in all conditions.	
Power	Connected to Key Switch Accessory position	

(The HEST Lamp also provides a warning to the operator if, apart from the manual-regeneration process, exhaust system temperature exceeds the limit values within the cleaning system.)

**WARNING BUZZER**

A warning buzzer sounds under the following conditions.

Warning	Buzzer Pattern	Condition
Low air pressure	Continuous beep	Parking brake is released when air pressure is low.
Engine overheat	Continuous beep	Engine has overheated.
Back up	Long, repeated beep	Gearshift switch is placed in "R" position.
Parking brake ON	Continuous beep	Vehicle is driven with the parking brake engaged.

**ADVICE**

- The warning buzzer may not sound if there is a problem with the system. If this occurs, the system needs to be inspected. Please contact the nearest Isuzu Dealer.

## SWITCHES



## INFO SCREEN

0°C		00:00	00/00/0000
Text			
Engine Information	Engine Coolant Temperature -40°C		
Oil Information	Engine Total Hours of Operation 0:0		
Software Version Information	Transmission Oil Temperature -40°C		
Cluster Software Number CITIPOINT_vD0.0.0_0	8388736	Oil Pressure 0 kPa	
oMUX 22x24Software Number 0001			
oMUX 36x41Software Number 3844985660			



## BSIS-MOIS Screen

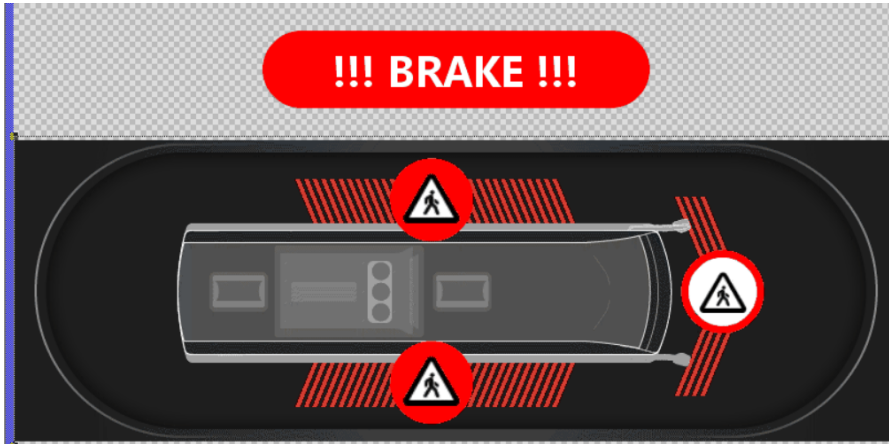

## Parking Sensor Screen

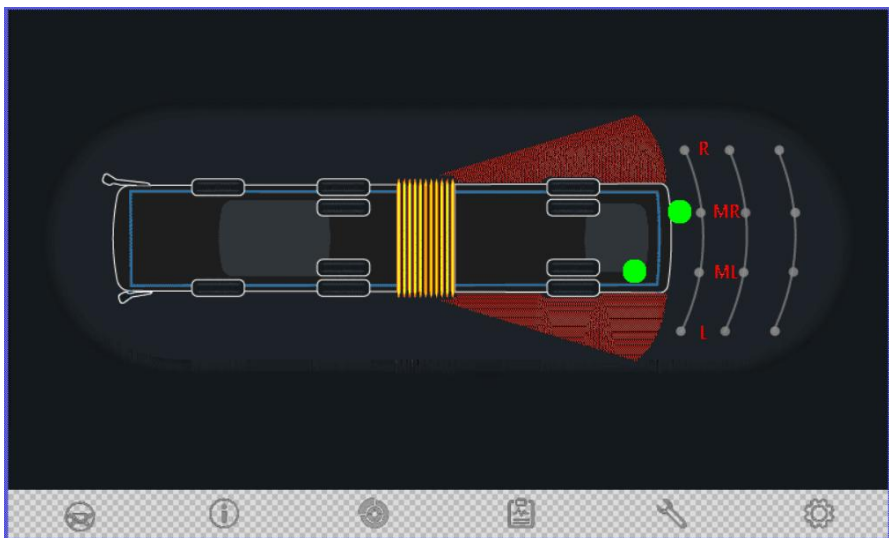

## Setting Screen

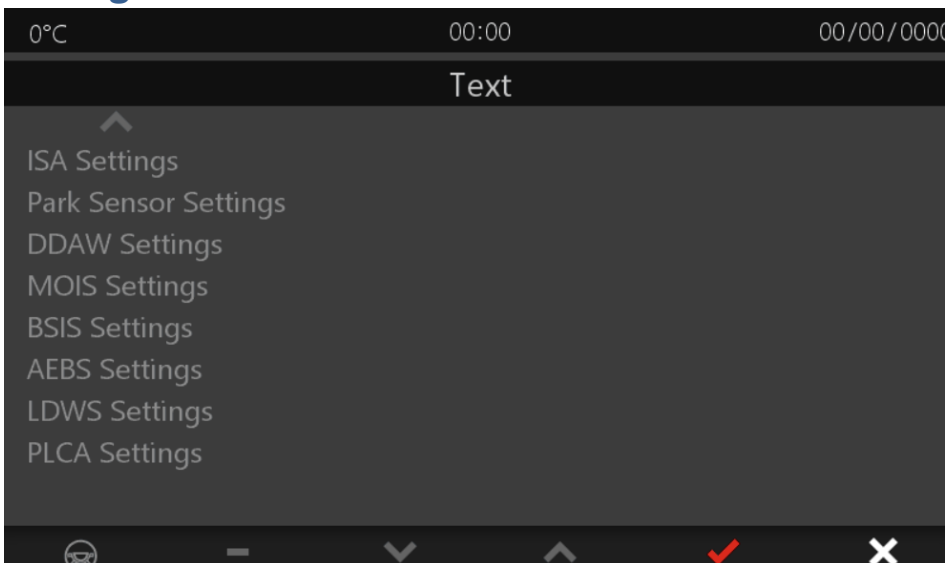

## Parameter Display Screen

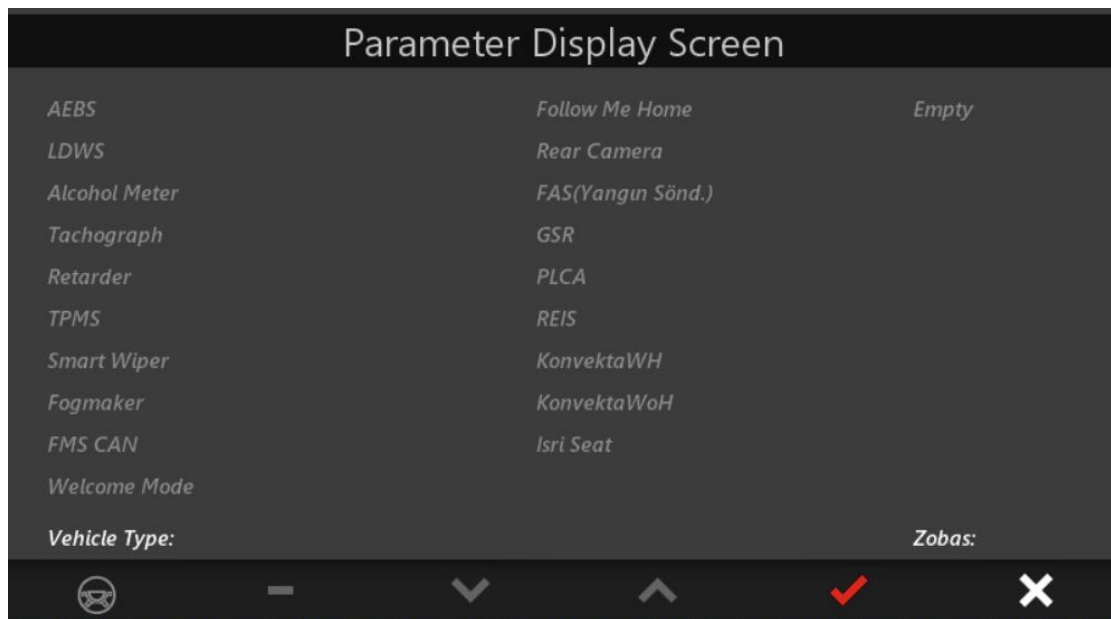

## SELF-SERVICE DOOR ALGORITHM

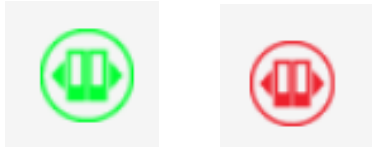

Red and yellow warning articulation is displayed on the bellows portion of the vehicle icon.

Depending on whether the doors are single- or double-winged, they are displayed in green on the vehicle icon.

If an error condition exists, the door icons turn red.

### Passenger Permission

Allows passengers to open the doors using the buttons on the doors and the cluster shelters. If the permission is active, the button LEDs on the shelters will light green; otherwise, they will light red. Additionally, an icon of the same color will appear on the cluster. These buttons only work if the door is closed or closed. They are not used to closing the doors. The doors will automatically close if no obstacle is detected for 5 seconds. If the disabled button is pressed, the permission will automatically be canceled. If the ignition is turned off, the permission will be automatically canceled. If the permission is active and the passenger presses the door open button while the vehicle is moving, the green LED on the shelters and the cluster permission icon will blink, and the door will open when the vehicle stops. If the driver cancels the permission at this time, the doors will not open.!

**RISK: THE ALGORITHM WAS DESIGNED THIS WAY BECAUSE THE TENDER REQUIREMENTS ARE LIKE THIS. DOORS MAY BE OPENED WHEN STOPPED AT A RED LIFE OR IN TRAFFIC IF THE DRIVER FORGOT THEIR PERMIT ON. THIS ALGORITHM IS NOT RECOMMENDED.**

NO	Meaning (ING)
<b>PopUp1</b>	Attention fire detected.
<b>PopUp2</b>	Please Stop the Engine and Check Warning
<b>PopUp3</b>	Don't stop the Engine, DPF Regeneration is active
<b>PopUp4</b>	Emergency Switch Active
<b>PopUp5</b>	DPF Regeneration Will be Active
<b>PopUp6</b>	Warning!!The engine room open ..!
<b>PopUp7</b>	AdBlue level low !!!Fill in the Adblue tank before the engine failure ...
<b>PopUp8</b>	Wait to start !
<b>PopUp9</b>	Door(s) Locked
<b>PopUp10</b>	Fuel Filling Cap Open!!!
<b>PopUp11</b>	Disabled Ramp Open!
<b>PopUp12</b>	System in Maintenance Mode
<b>PopUp13</b>	Air Conditioning System Error!
<b>PopUp14</b>	Press the brake to start.
<b>PopUp15</b>	The cluster will close within
<b>PopUp16</b>	Attention Please ! Front Emergency Valve is Open !
<b>PopUp17</b>	Attention Please ! Rear Emergency Valve is Open !
<b>PopUp18</b>	Press the clutch to start.
<b>PopUp19</b>	Attention Please ! Mid Emergency Valve is Open !
<b>PopUp23</b>	Disabled lift door open.
<b>PopUp20</b>	Warning!!! Odometer KM Changed!!!
<b>PopUp21</b>	Roof Lamps Are Active!
<b>PopUp22</b>	Don't Forget Pull The HandBrake!!!
<b>PopUp23</b>	Trip is Reset!
<b>PopUp24</b>	Warning!!The park lamp open !
<b>PopUp25</b>	Complete the Installation Procedures!
<b>PopUp26</b>	Door malfunction ! 1.
<b>PopUp27</b>	Door malfunction ! 2.
<b>PopUp28</b>	Please Select the Halt Brake Auto Mode!!!
<b>PopUp29</b>	Halt Brake Disable Switch Active
<b>PopUp30</b>	Attention fire detected.Battert Room
<b>PopUp31</b>	Left Brake Lamp Broken Please check it!
<b>PopUp32</b>	Right Brake Lamp Broken Please check it!
<b>PopUp33</b>	"Wiper Park Signal Error!"

## STARTER SWITCH

### WARNING

- While driving, never turn the starter switch to the "LOCK" position. The key could be removed from the switch, which then locks the steering wheel. This is extremely dangerous.

### ADVICE

- Using a key sticking with dirt or dust, etc. may possibly damage the starter switch. Make sure to wipe off any dirt or dust, etc. before inserting the key.
- After starting the engine, do not turn the starter switch to the "START" position. Otherwise, the starter motor may be damaged.
- Using electrical devices such as the audio system for an extended time period with the engine stopped can completely discharge the battery.

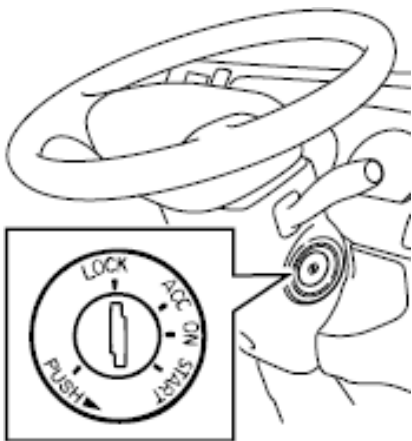

**LOCK:** In this position, the key can be inserted or removed. Remove the key and turn the steering wheel until it locks. The steering wheel will be locked to help prevent theft. To place the starter, switch in the "LOCK" position, press and hold the key in the "ACC" position and then turn it to the "LOCK" position.

**ACC:** In this position, the audio and other accessories can be used with the engine stopped.

**ON:** The key stays in this position while the engine is running.

**START:** The engine is started in this position. Release the key as soon as the engine has started. The key automatically returns to the "ON" position.

### NOTE

- If the key cannot be turned from the "LOCK" position to the "ON" position, lightly move the steering wheel clockwise and counterclockwise while trying to turn the key.

## LIGHT CONTROL SWITCH



Turning the light control switch to the position indicated in the table causes the relevant lights to illuminate.

The light control switch can be used when the starter switch is placed in the "LOCK" or "ACC" position.

Name	○	☰☱	☰☲	☱☳
Headlights	Off	Off	On	On
Clearance lights		On		
Taillights			Off	
License plate light		Off		
Rear fog lights	Off	Off		
Daytime running lights	On		Off	

## TURN SIGNAL AND WINDSHIELD WIPER SWITCH

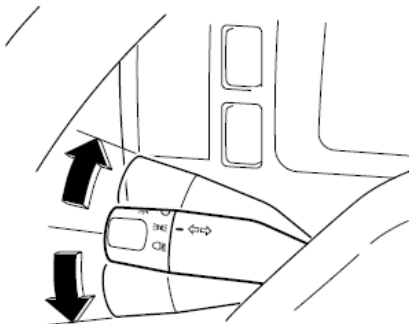

When turning left or right, move the lever up or down to flash the turn signal light.

### NOTE

- If the steering wheel is only turned a small amount, turn off the signal manually. Lightly press and hold the lever up or down when overtaking or changing lanes. The turn signal light continues flashing as long as the lever is held up or down. The lever moves back to neutral as soon as it is released.

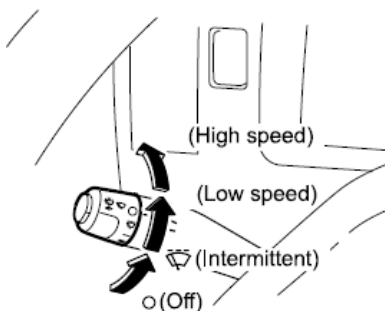

To use the windshield wiper and washer lever, the starter switch must be in the "ON" position.

Windshield washer fluid is sprayed over the windshield when this lever is pulled. At the same time, the windshield wiper operates.

### CAUTION

- At extremely low temperatures, washer fluid may freeze on the windshield after being sprayed, obstructing your forward view. In such a case, warm up the windshield before using the windshield washer.

## ADVICE

- The safety system may work to stop the wiper when excessive load is applied on the motor. In this case, turn the switch to the off position and, a few minutes later, check to see if the wiper is back to normal operation. If the wiper frequently stops operation, refrain from using it and contact the nearest Isuzu Dealer.
- Before operating the wiper, ensure that the wiper is not stuck on to the windshield. If the wiper rubber is stuck to the windshield and you still operate the wiper, the wiper may break or the wiper motor may fail.
- Do not operate the wiper on a dry windshield surface. Otherwise, the windshield surface may sustain damage. Always use the windshield washer when wiping a dry glass surface.
- If windshield washer fluid does not come out in sufficient quantity, immediately release the switch. Otherwise, the motor may seize up.
- Do not hold the lever pulled for more than 30 seconds. Otherwise, the washer pump may sustain damage.
- When the vehicle is used in a cold-climate region, use washer fluid with appropriate concentration for the season to prevent frozen fluid.

## RETARDER SWITCH

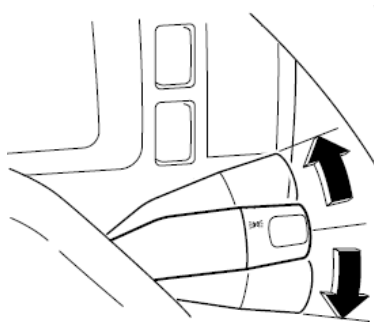

To apply the retarder while driving, move the lever down.

### CAUTION

- It is extremely dangerous to apply the retarder on slippery roads (with their surfaces being wet, frozen, or covered with compacted snow) as the tires can skid.

## Conditions for Inoperable Retarder

Under the following conditions, the retarder does not engage.

- The accelerator pedal is pressed.
- The gearshift switch is in the "N" position.
- The vehicle is traveling at 5 km/h (3 MPH) or lower speeds.
- The engine speed is close to idling.
- During gear shifting.

---

## HAZARD WARNING FLASHER SWITCH



The hazard warning flasher is used to signal other vehicles that your vehicle is stationary on the road because of an accident or component failure.

With the starter switch in any position, when this switch is pressed, all of the turn signal lights and the turn signal indicator lights flash to signal an emergency. To turn off the hazard lights, press the switch again.

---

## MIRROR HEATER SWITCH



Use the mirror heater to defrost the mirror surface. With the starter switch in the "ON" position, press the mirror heater switch to turn on the mirror heater. Press the switch again to turn it to "OFF".

### ADVICE

- Do not use the mirror heater while the engine is not running. The mirror heater consumes a lot of electricity and could discharge the battery completely.

---

## DRIVER SIDE WINDOW HEATER SWITCH



Use the driver side window heater to defrost the driver side window surface. With the starter switch in the "ON" position, press the window heater switch to turn on the window heater. Press the switch again to turn it to "OFF".

---

## CEILING LIGHT SWITCH



Use the ceiling light switch to control the modes of the ceiling light. According to the position of the switch: lights partially turn on, lights fully turn on or lights turn off.

---

## DRIVER SIDE CEILING LIGHT SWITCH



The driver side ceiling light switch can be used when the starter switch is placed in the "ON" position. Use this switch to open and close the driver side ceiling light.

---

### ROLLER BLIND SWITCH



Use the roller blind switch to control the windshield roller blind.

---

### STEERING WHEEL ADJUSTMENT SWITCH



To unlock and adjust the position of steering wheel, press the steering wheel adjustment switch. Press the switch again to lock the position of the steering wheel.

### BUS STOP BRAKE SYSTEM



The bus is equipped with a door override button that allows the driver to temporarily deactivate the halt brake, enabling the vehicle to move at speeds of up to low speeds. To ensure safety and proper use, the button is fitted with a protective cover and a breakable seal to prevent unauthorized activation. Additionally, the vehicle's telematics system is designed to detect and record any use of the door override button, providing supervisory oversight and enabling monitoring of such events.

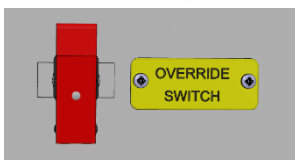

---

## DESTINATION INDICATOR SWITCH



Use the destination indicator to activate the destination route display. With the starter switch in the "ON" position, press the destination indicator switch to turn on the destination indicator display. Press the switch again to turn it to "OFF".

---

## REMOTE CONTROL MIRROR SWITCH

Left/Right selector switch

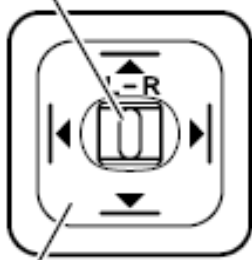

Angle adjustment switch

The remote control mirror switch is active only when the starter switch is in the "ACC" or "ON" position.

---

### Adjust

1. Press the left/right selector switch on the "L" or "R" side to move the mirror to the desired direction.
2. Press the angle adjustment switch to adjust the mirror angle.

### ADVICE

- Do not try to forcefully move the mirror surface by hand.

Otherwise, the mirror motor may sustain damage.

---

## DRIVING HEIGHT SWITCH



Use the driving height switch to maintain a higher driving level. Press the upper end of the switch to maintain a higher driving level and lower end to come back to normal driving position.

---

**KNEELING SWITCH** Use the kneeling switch to tilt the vehicle to right side. Press the lower end of the switch to tilt the vehicle and upper end to come back to driving position.

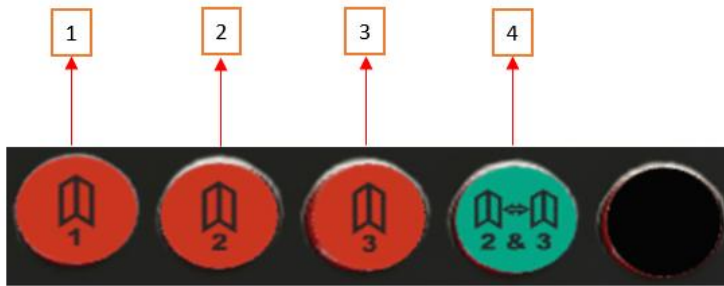

**DOOR OPEN/CLOSE SWITCH****ICON NO FUNCTION**

- 1 Opens and closes the first door.
- 2 Opens and closes the second door.
- 3 Open and close the third door.
- 4 Opens and closes the second and third doors simultaneously.



---

### AUTOMATIC RIGHT TILT SWITCH



When the vehicle stops at the stop, it automatically makes the vehicle lean to the right so that the passengers can get on and off.

---

### RETARDER CANCEL SWITCH



The retarder foot brake control switch is used to disable the retarder.

---

### REGENERATION SWITCH



The regeneration is started by pushing on the switch.

---

### REVERSE GEAR BUZZER SWITCH



When the lower end of the switch is pressed, the Reverse Buzzer is activated, and when the upper end is pressed, it is deactivated.

---

### CANCEL BUTTON TO STOP



This key is used to cancel the request without opening the doors when the stop button is pressed.

## DRIVING CONTROLS

### PEDALS

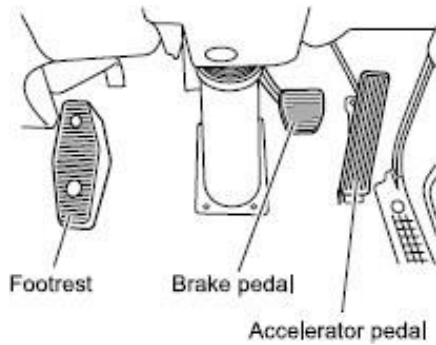

Sit in a correct driving position on the seat and operate the brake pedal and accelerator pedal with your right foot.

To avoid accidentally pressing the wrong pedal, check the pedal positions and practice putting your foot on the desired pedal.

#### NOTE

- If the accelerator pedal is depressed further after being almost fully depressed, it will be possible to forcibly shift into a lower gear (kick down). This will enable the rapid acceleration necessary to overtake other vehicles or climb steep slopes, etc.

### GEARSHIFT SWITCH



There is a gear selector with 6 buttons in the vehicle. These buttons are:

**1, 2, 3 buttons** : They are used for limiting the maximum gear value that the transmission can raise.

**D button** : Automatically Forward

**N button** : Idle Gear

**R button** : Reverse Gear

The transmission should be at "N" position while the engine was running. When the ignition switch is turned on first of all the buttons light for 1 - 2 seconds, then only the selected button lights. If the selected button flashes, it means that the selected gear was not accepted by the transmission control unit since the suitable conditions could not provide for the shift of the gear. If all the lights are flashing, it means that the gear selector was malfunctioning or there is a problem in the wirings of the vehicle data communication system (CAN). When pressed on more than one button by fault, the transmission performs the lowest gear selected. For example, when it is pressed on D and 3 buttons at the same time, the transmission shall consider the 3 buttons.

## PARKING BRAKE LEVER



Pull the parking brake lever from the fully released position to the lever locked position. The parking brake warning light will then come on. Make sure that you hear the air being released from the system.

To release the parking brake, lower the parking brake lever while raising the release knob. The parking brake warning light will then go out.

### CAUTION

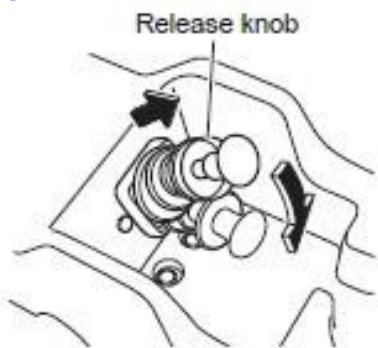

### Parking brake warning light



- When parking or stopping your vehicle, pull the parking brake lever and make sure that the vehicle does not start moving.
- Avoid parking your vehicle on a slope as much as possible and choose a level and flat place. If it is unavoidable to park your vehicle on a slope, be sure to set the parking brake fully, make sure that the vehicle does not move, and block the wheels with chocks for added safety. Engage the transmission in a gear for more secure parking.
- Do not use the parking brake while the vehicle is in motion except in an emergency. Applying the parking brake before the vehicle has stopped can cause the tires to lock or the vehicle to spin, possibly causing an accident.
- Unless the parking brake is fully released during driving, a fault and/or a fire may be caused.
- Illumination of the parking brake warning light does not mean that the parking brake is fully applied. The parking brake lever must be fully pulled up.
- After using the parking brake during driving, be sure to check if any failure has been caused.

---

## ANTI-LOCK BRAKE SYSTEM (ABS)

Wheels may be locked and slip during sudden braking or braking on a slippery road surface such as a snowy road. ABS is a device to prevent the wheels from locking by detecting a slippery condition during braking and to secure directional stability and handling stability of the vehicle. ABS is only to assist in slippery conditions and will not prevent an accident if you exceed safe driving speeds for road conditions. Always drive safely.

### CAUTION

- ABS does not prevent accidents if you do not drive safely. Drive the vehicle at a safe speed.
- Install tires of the specified size, same brand and same tread design (including winter tires) on all wheels. If different tires are installed, the braking distance becomes longer and directional control stability of the vehicle decreases. This is very dangerous.
- Steering during sudden braking (when the ABS is working) will feel slightly different than it does when the brakes are not applied. Operate the steering wheel carefully keeping this in mind.
- For full-air brake models, ABS operation consumes the brake system air. When the air pressure drops and the air pressure warning light and the buzzer are activated, immediately stop the vehicle at a safe place and wait for the required air pressure to be recovered before driving.

### ADVICE

- Driving in sand or on a muddy road may adversely affect the brakes and ABS sensors. Wash the vehicle to remove sand and mud after operating the vehicle in sandy or muddy conditions.
- Before washing the vehicle, provide necessary protection to prevent water from being splashed on the ABS components (sensors and actuators). Especially when using high-pressure washing, be careful not to allow water to be directly sprayed onto the ABS components and their harness connectors.

### NOTE

- ABS is not activated immediately after starting the vehicle. It is activated only when the vehicle speed reaches approx. 10 km/h (6 MPH). ABS operation is inactive when the vehicle speed reduces to approx. 5 km/h (3 MPH).

---

## ABS Operation Indications and Signs

### ABS warning light



When the starter switch is placed into the "ON" position, the ABS warning light comes on and then goes out in approx. 2 seconds. The ABS is normal if the warning light goes out.

When ABS is activated, slight vibration is generated on the steering wheel and an operating sound can be heard from the ABS equipment.

**NOTE**

- If the ABS warning light does any of the following, the ABS may be faulty. Please contact the nearest Isuzu Dealer.
  - If the ABS warning light comes on during driving
  - The light does not come on when the starter switch is placed into the "ON" position
- Even if a problem has occurred with the ABS, the regular brakes will still work normally. However, ABS will not operate.

---

**Precautions for Driving an ABS-Equipped Vehicle**

ABS is not a device that enables driving and stopping under conditions exceeding safe driving limits. Always drive safely.

**CAUTION**

- When braking suddenly, continue pressing brake pedal hard so that the ABS can take effect.
- When braking suddenly, do not pump the brakes (pushing and releasing the brake pedal little by little). Pumping brakes will increase the braking distance.
- The braking distance on slippery road surfaces is longer than that on a normal dry paved road even with an ABS-equipped vehicle. When ABS is activated in the following road surface conditions, the braking distance may be slightly longer compared to that of vehicles not equipped with an ABS. Therefore, always be aware of the road and tire condition (tire type and wear condition), observe safe driving habits and drive the vehicle while keeping a safe following distance.
  - When driving on a gravel road, or a road with a deep snow covering.
  - When tire chains are used.
  - When driving over road joints or bumps such as light reflectors on the road.
  - When driving on a bumpy road, stone-paved road or track.
  - When driving over an iron plate or manhole lid.
- ABS does not work for wheel skid during a standing start, acceleration and cornering which do not involve braking. On a very slippery icy road, tires may lose grip and steering wheel operation may not be able to control the vehicle's direction, resulting in very unstable driving. Always drive the vehicle observing a safe speed well matched with both road surface and tire conditions, and avoid sudden braking.
- If powerful engine braking is applied on a very slippery icy road, the drive wheels may be locked (the ABS then does not work), resulting in loss of vehicle control. If this happens with a manual transmission vehicle, disengage the clutch or place the gearshift switch into the "N" position to prevent engine braking from acting on the drive wheels. Then, drive the vehicle with the gearshift switch placed in an appropriate gear.
- When ABS is activated, a slight vibration (especially when the road surface is different between right and left wheels) and pulling may be felt on the steering wheel. In addition, an operating sound is produced from the ABS actuators. This does not indicate any abnormal condition. Stay calm and operate the steering wheel properly.

---

## ANTI-SLIP REGULATOR (ASR)

ASR is a device that helps prevent the drive wheels from spinning and improve vehicle motion stability when driving on a snowy or otherwise slippery road surface. The ASR is automatically activated when the engine is started. You may cancel the ASR operation using the ASR OFF switch.

### CAUTION

- When ASR is activated, the ASR indicator light (green) comes on. The road surface at this time is very slippery. If the indicator light comes on, drive carefully and reduce the speed sufficiently before negotiating a curve.
- Even with the ASR-equipped model, when driving on a snowy or icy road, carefully drive the vehicle, installing tire chains or winter tires.
- ASR is not a device to drastically improve the vehicle starting performance. Carefully operate the accelerator pedal when moving on an icy slope.
- When tire chains are installed, it may be easier for you to start the vehicle to move on an icy slope if the ASR is canceled. Be aware, however, that ASR deactivation will result in reduced stability of vehicle operation.

### NOTE

- You may notice minimal vibrations or operating sound when starting and accelerating the vehicle on a slippery road. This sound is generated when ASR is operating.
- The engine speed may suddenly decrease, but this is because the ASR device is operating.

---

### ASR OFF Switch



Use this switch when you want to cancel the ASR. When you press this switch while the ASR is active after starting the engine, the ASR is cancelled and the ASR indicator light (amber) in the instrument panel comes on. When the switch is pressed again, the ASR function turns back on.

### ADVICE

- When you turn off the ASR, it will not be available to assist you in slippery driving conditions. Always use caution when driving on slippery roads.
- Be sure to enable the ASR during normal driving.

### NOTE

- If the ASR is off when the engine is turned off, it is automatically re-enabled when you restart the engine.

---

## ASR Operation Check and ASR Operation

### ASR indicator light



**(Green/Amber)**

When the starter switch is turned to the "ON" position, the ASR indicator light comes on amber and then turns green before it goes out in about 2 seconds. ASR is normal if the indicator light goes out.

When ASR is operating, the ASR indicator light (green) comes on. When the ASR OFF switch is pressed, the ASR indicator light (amber) comes on.

### NOTE

- If the ASR indicator light does any of the following, ASR may be faulty. Please contact the nearest Isuzu Dealer.
  - When the ASR indicator light (green) remains on while driving on a firm, dry road.
  - When the ASR indicator light (amber) comes on during driving (when the ASR OFF switch is not operated).
  - The ASR indicator light does not come on when the starter switch is turned to the "ON" position.
- If the ASR is faulty, it does not interfere with normal driving. However, the ASR will not function.

---

## Precautions for Driving an ASR-equipped Vehicle

ASR is not a device that enables driving under conditions exceeding safe limits. Always drive safely.

### CAUTION

- The ASR does not increase the road grip of tires although it improves the starting and accelerating performance on a slippery road surface when compared to a model without ASR. On an icy or otherwise slippery road, the grip of tires decreases which also reduces steering control, resulting in unstable vehicle behavior. Always drive the vehicle observing a safe speed well matched to the road surface and tire conditions, and also avoid speeding.
- Even if ASR is equipped, avoid sudden operation of the accelerator pedal and steering wheel. Especially when starting the vehicle on a slippery road, start up slowly as you would in a vehicle without ASR.

### NOTE

- When you drive up a slippery, long slope by increasing the engine speed, where the tires may slip, or when you want to dislodge the vehicle from a deep snowy road or mud, you can press the ASR OFF switch to disable the ASR system.

---

## ELECTRONIC BRAKE SYSTEM (EBS)

EBS (Electronic Brake System) is a system that adds electronic signals to the brake air control system (sent by the brake pedal when it is depressed) in order to improve air brake responsiveness. The EBS maintains the same brake feel regardless of whether the vehicle is loaded or not and is a device that enhances driver operability and safety.

### CAUTION

- The EBS is not a device to counteract unsafe driving practices. Always maintain a safe speed as well as a safe distance between yourself and other vehicles.
- All tires installed to the vehicle should be of the specified size, as well as be of the same brand and with the same tread design (this includes winter tires). Installing different types of tires to the vehicle is dangerous and could result in reduced braking ability and unstable vehicle operability.

---

### EBS Operation Check, Operation, Malfunction

#### Brake warning light



When the starter switch is turned to the "ON" position, the brake warning light comes on before going out approximately 3 seconds later. The EBS is normal if the warning light goes out. If the warning light does not come on even when the starter switch is turned to the "ON" position, it may be possible that the bulb has burned out or there is an EBS malfunction.

When EBS is operating, operating sounds can be heard from the EBS components.

If the brake warning light comes on or flashes during driving, the EBS, ABS/ASR may be malfunctioning. Please contact the nearest Isuzu Dealer.

### NOTE

- Even if the EBS has malfunctioned, the regular brakes will still operate normally. Because the EBS will be inoperable at this time, it will be necessary for the brake pedal to be depressed more strongly than normal in order to achieve the required brake force.

---

### Driving Precautions for Vehicles Equipped with EBS

The EBS is not so versatile that it enables driving under conditions that exceed safe limits. Always drive safely.

### WARNING

- If the starter switch is turned to the "ON" position (engine start-up) on a slope, etc., the EBS may be affected due to a battery voltage decrease, resulting in the vehicle moving down the slope. After either pulling the parking brake lever or fully depressing the brake pedal, turn the starter switch to the "ON" position (engine start-up).

## CAUTION

- Although models with EBS may have enhanced brake responsiveness when compared to models without EBS, the EBS is not a device to counteract unsafe driving practices. Always drive the vehicle while observing a safe speed.
- In models with EBS, the EBS is activated when the brake pedal is depressed, regardless of whether the starter switch is turned to the "LOCK" position. Even if the starter switch is turned to the "ON" position with the brake pedal depressed, emissions from the EBS device are not vented. (In this case, the EBS system operation check will not be performed.) If exhaust sounds cannot be heard from the EBS system when the brake pedal is depressed and released, the EBS exhaust port may be frozen or blocked by snow or ice which must be removed.
- If battery voltage becomes low, EBS operation may be affected. Periodically inspect the battery.
- In models equipped with EBS, the vehicle's computer detects loading conditions, making it unnecessary for drivers to adjust how they depress the brake pedal, regardless of whether or not the vehicle is loaded or empty. However, as with vehicles not equipped with an EBS system, braking distance will be increased if the brake pedal is not sufficiently depressed when the vehicle is empty.
- The EBS will not function to its full capacity if the driver pumps the brake pedal instead of depressing it fully. Pumping the brakes will also lead to a decrease in brake performance caused by an increase in air. ("Pumping" the brakes is defined as continually depressing the brakes at a rate of once or more each second.)

## ADVICE

- When installing an electronic device such as a radio, pay attention to the installation position and routing so that EBS functionality is not affected. Also, when installing, please contact the nearest Isuzu Dealer.

---

## How to Make the EBS Function Correctly

Using the brake pedal stroke amount together with the vehicle deceleration rate, the EBS calculates loading conditions and determines the braking strength. If loading conditions change, the EBS recalculates the weight. This recalculation will be completed only after the vehicle has been brought to a complete stop from a speed of 30 km/h (19 MPH) or more a total of 3 to 4 times without the brakes being pumped.

## CAUTION

- When the brake warning light is illuminated, it signals that an EBS malfunction has occurred. In this case, although the feeling of the brakes will change considerably due to the in operation of the EBS, the regular brakes will still operate normally. If the EBS malfunctions, firmly depress the brake pedal, stop the vehicle, and contact your nearest Isuzu Dealer.

---

## UREA SELECTIVE CATALYTIC REDUCTION (SCR) SYSTEM

The urea SCR system uses urea<sup>®</sup> to reduce nitrogen oxides (NOx) in exhaust emissions.

### WARNING

- Do not put anything other than Urea<sup>®</sup> in the Urea<sup>®</sup> tank.
- When refilling Urea<sup>®</sup>, doing any of the following may cause a fire or malfunction of the urea SCR system.
  - Diluting with water or other liquids
  - Adding gasoline or diesel fuel
- If liquids, etc., other than the specified Urea<sup>®</sup> have been accidentally added, the urea SCR system must be inspected. Have the urea SCR system inspected/serviced at your Isuzu Dealer.

### CAUTION

- Urea<sup>®</sup> is harmless to the human body even if touched. However, it may cause inflammation in rare circumstances depending on its constitution. In such cases, take the following actions.
  - In the case of contact with skin, wash off with water. Failure to do so may result in irritation for those with sensitive skin.
  - In the case of accidental ingestion, drink one or two glasses of water or milk and consult your physician immediately.
  - In the case of contact with eyes, immediately wash out with large amounts of water for at least 15 minutes and consult your physician.

### ADVICE

- Use urea<sup>®</sup> specified by Isuzu.
  - Use urea<sup>®</sup> that is compliant with the ISO (International Organization for Standardization) 22241 standard defined for AUS 32.
- Do not modify the exhaust pipe or muffler, or change the location of any items including the urea<sup>®</sup> tank. Doing so could affect exhaust emission reduction capabilities. If any modifications or relocation is necessary, consult your nearest Isuzu Dealer.

### NOTE

[Urea SCR]

- Urea SCR stands for "Urea Selective Catalytic Reduction". In this technology, urea is used as the selective catalytic reducing agent.

[urea<sup>®</sup>]

- Urea<sup>®</sup> is an aqueous solution especially for use with urea SCR systems.
- Urea<sup>®</sup> freezes at a temperature of -11°C (12°F). Since the urea SCR system is equipped with a heating function that utilizes the engine coolant, the engine will start even when Urea<sup>®</sup> is frozen.
- Urea<sup>®</sup> is a registered trademark of Verband der Automobil industrie (VDA).

## EMERGENCY KEY SYSTEM

- If the vehicle speed is more than 3 km/s doors would not open/close.
- Doors would automatically close when the vehicle speed is 3 km/s if the bus top brake is set manually and vehicle is moved with doors open.



### If the emergency key is activated:

- Ceiling lights gets II. Level activated.
  - Courtesy lights get activated.
  - Hazard lights get activated.
  - Driver lighting gets activated.
  - Host lighting gets activated.
  - Cluster, gives a visual and vocal warning.
  - Low voltage system is deactivated.
  - Passenger door opening permission is cancelled.
- Automatic door closing is not activated.

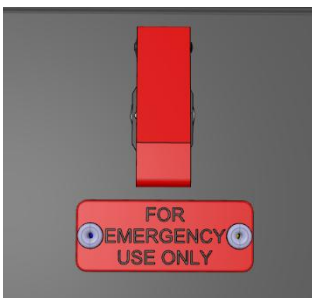
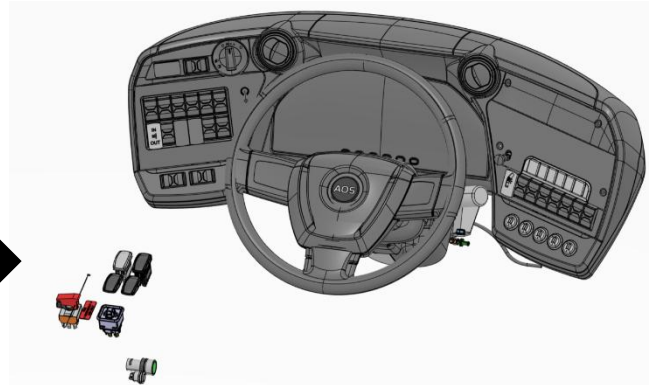

- **If emergency door valve gets activated:**  
Ceiling lights gets II. Level activated.
- Courtesy lights get activated.
- Hazard lights get activated.
- Driver lighting gets activated.
- Host lighting gets activated.
- Cluster, gives a visual and vocal warning.

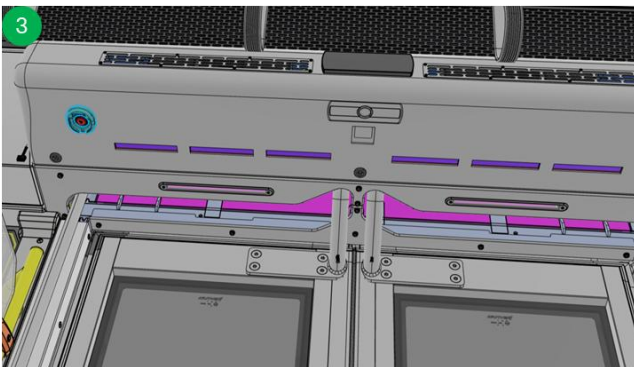
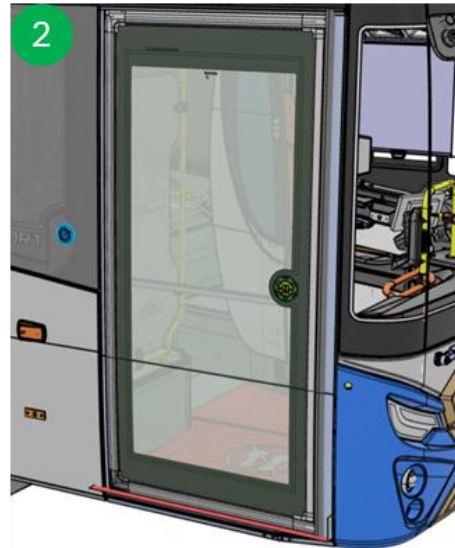
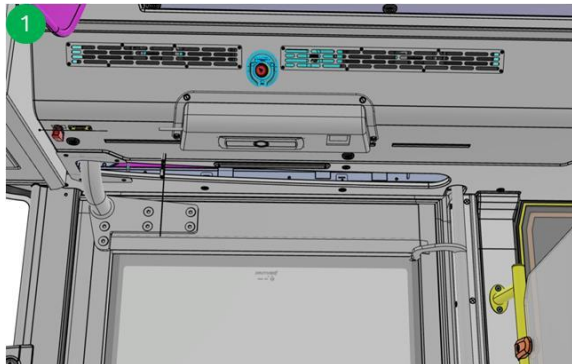
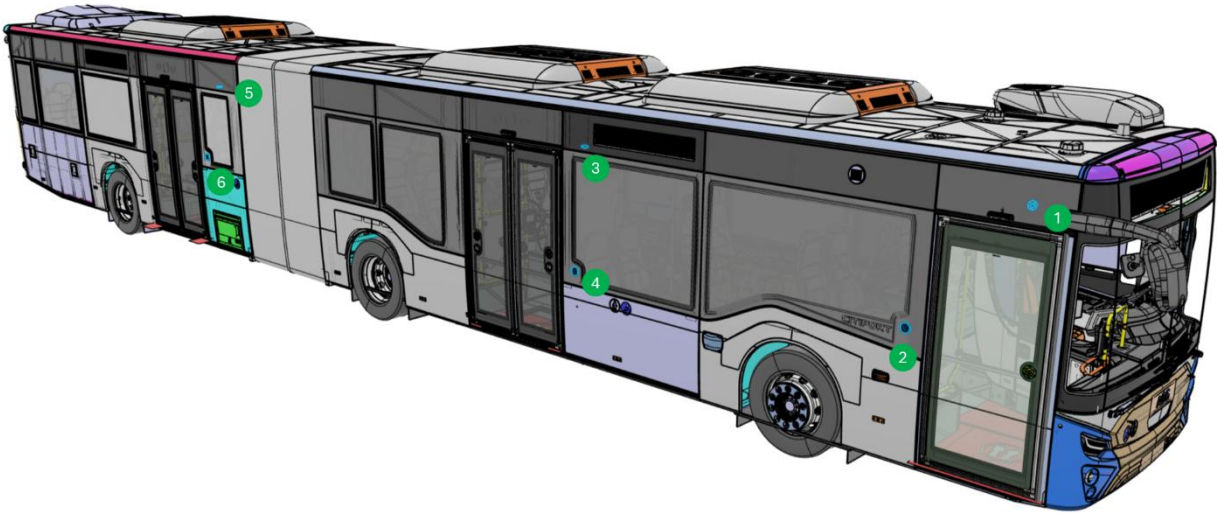

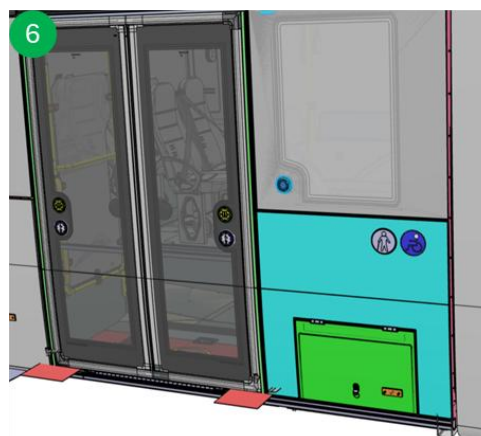
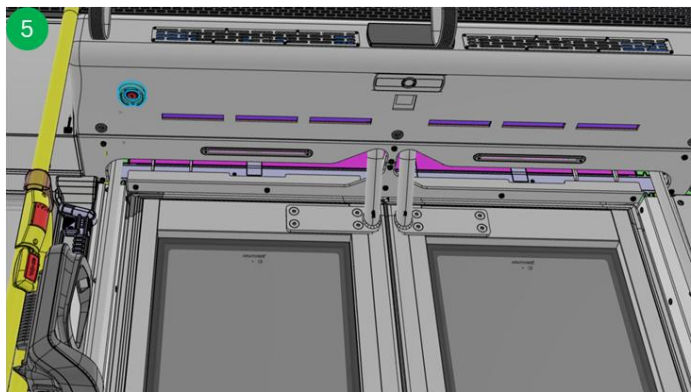

## HAZARD LIGHTS SYSTEM

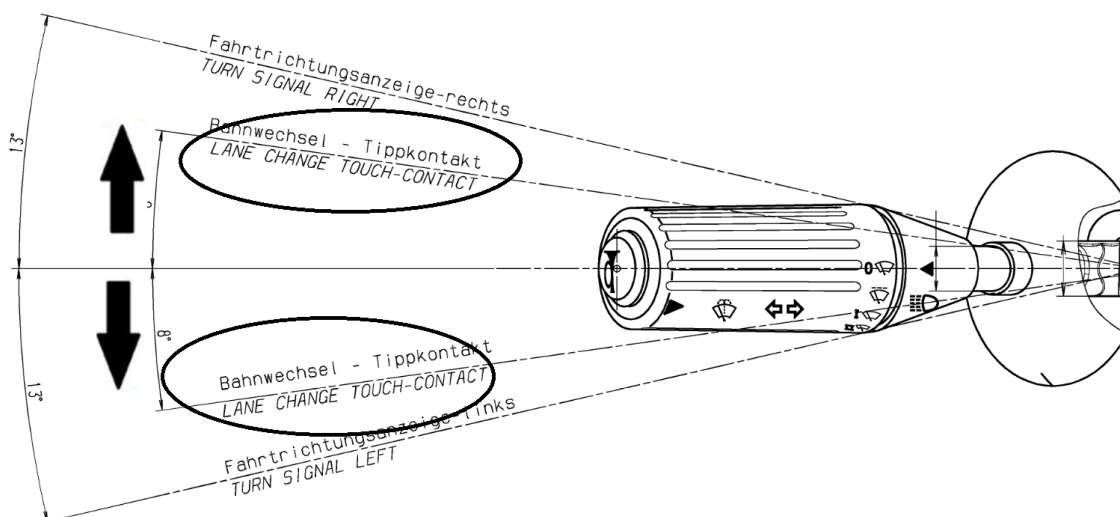

### Signal functions:

1. To signal changing lanes, handle is moved lightly to the corresponding direction.
2. If the hazard lights button is pressed while left or right lights are on, hazard lights gets turned on.
3. If the hazard lights button is pressed while right light is activated, hazard lights gets turned on then (without turning hazard lights off) if right signal handle gets activated after being deactivated, right signal lights are activated.
4. If the hazard lights button is pressed while left light is activated, hazard lights gets turned on then (without turning hazard lights off) if the left signal handle gets activated after being deactivated, left signal lights are activated.
5. If the hazard lights button is pressed while left or right lights are on, right or left signal lights get activated.



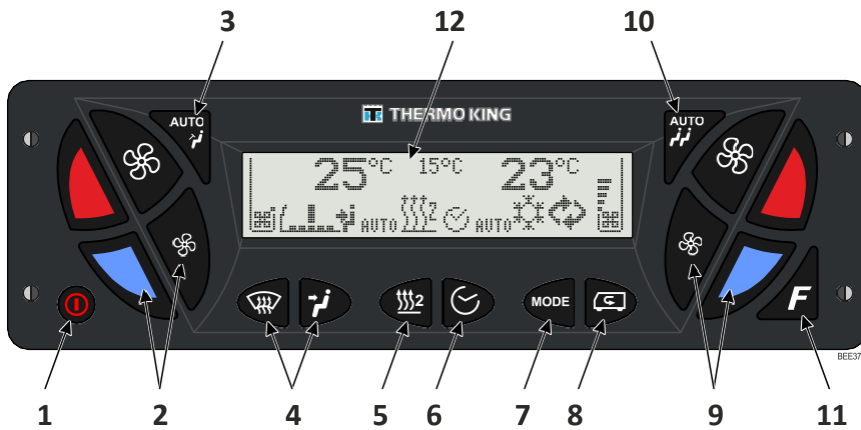

# COMFORT AND CONVENIENCE

## AIR CONDITIONER CONTROL UNIT (Thermoking)

### CANAIRE Controller (Frontbox and main A/C)



1.		<p>ON/OFF button.</p> <p>Two possibilities when driver panel is powered:</p> <ul style="list-style-type: none"> <li>Welcome screen with actual date and time and TK logo &gt; driver panel is powered but out of operation &gt; to start press ON/OFF button.</li> <li>Standard operating screen.</li> </ul>										
2.		<p><b>Driver's area control</b></p> <p>Press red or blue button to set temperature<sup>(a)</sup>. Press ventilator buttons to set air flow.</p>										
3.		<p><b>Driver's area control</b></p> <p>Automatic control of required temperature<sup>(b)</sup>.</p>										
4.		<p>Air flow direction (Air distribution damper position)</p> <p>Press to change flow direction to windscreen or driver or to start defrost function.</p>										
5.		<p>Preheater ON/OFF button. /This function is optional and is not included in this vehicle.</p>										
6.		<p>Preheater setting button — see ????. /This function is optional and is not included in this vehicle.</p>										
7.		<p>Operating Mode selection button — press repeatedly to change the mode: This function is inaccessible because it is controlled by the Telemetry system.</p> <table border="1"> <tr> <td></td> <td>Ventilation</td> </tr> <tr> <td></td> <td>Heating</td> </tr> <tr> <td></td> <td>Cooling</td> </tr> <tr> <td></td> <td>AUTO mode</td> </tr> <tr> <td></td> <td>Reheat<sup>(c)</sup> (TWO DROPS symbol – if available and configured)</td> </tr> </table>		Ventilation		Heating		Cooling		AUTO mode		Reheat <sup>(c)</sup> (TWO DROPS symbol – if available and configured)
	Ventilation											
	Heating											
	Cooling											
	AUTO mode											
	Reheat <sup>(c)</sup> (TWO DROPS symbol – if available and configured)											

8.		<b>SMOG button</b> Press to close both HVAC unit and Feedback Fresh Air dampers. To cancel press SMOG button again. SMOG mode is terminated automatically after pre-set period.
9.		<b>Passenger's area control</b> Press red or blue button to set temperature. Press ventilator buttons to set air flow. -This function is inaccessible because it is controlled by the Telemetry system.
10.		<b>Passenger's area control</b> Automatic control of required temperature - This function is inaccessible because it is controlled by the Telemetry system.
11.		Error messages appear when pressed for a long time.
12.		LCD graphic display — see ???.

- (a) The compressor is always controlled by HVAC unit. If the cooling function is required by Front Box only the compressor doesn't start.
- (b) The compressor is always controlled by HVAC unit. If the cooling function is required by Front Box only the compressor doesn't start.
- (c) Depends on system configuration.
- (d) Depends on system configuration.

## LCD Graphic Display

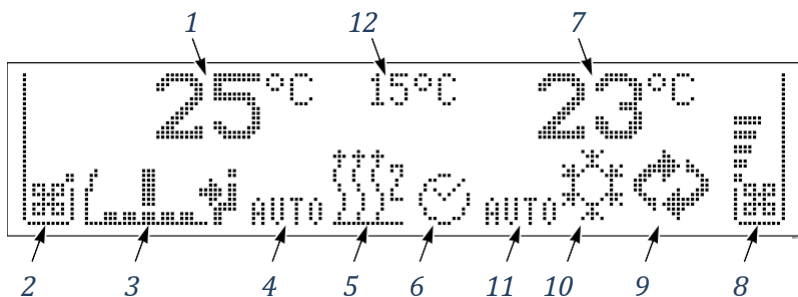

LCD Graphic's display



1.	Driver's area temperature set point (a)	7.	Passenger's area temperature set point <sup>(b)</sup>
2.	Driver's area – air flow indicator (Front Box blower speed)	8.	Passenger's area – air flow indicator (HVAC unit blower speed)
3.	Air flow direction (air distribution damper position) indicator	9.	SMOG icon
4.	Automatic mode of Front Box icon	10.	HVAC unit operating mode icon
5.	Preheater icon	11.	Automatic mode of HVAC unit icon
6.	Preheater timer icon	12.	Ambient temperature <sup>(c)</sup>

- (a) Depends on system configuration, driver panel or CANAIRE system setting.
- (b) Depends on system configuration, driver panel or CANAIRE system setting.
- (c) Depends on system configuration, driver panel or CANAIRE system setting.



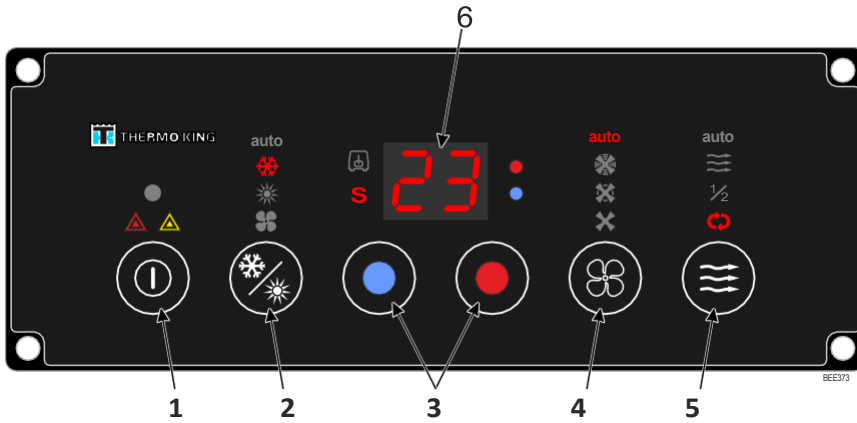

## Alarms Icons

	<b>Warning:</b> "YELLOW Alarm" ► long beep ► HVAC unit is operating, probably with some restriction ► arrange repair as soon as possible.
	<b>Alarm:</b> "RED Alarm" ► long beep and then short beeps repeatedly ► HVAC unit is operating in VENTILATION Mode only ► arrange repair IMMEDIATELY.

# ClimaAIRE I D Controller (Driver A/C)



1.		On/OFF button.		The Red Alarm (ALARM) symbol will shine in the following two conditions: <ul style="list-style-type: none"> <li>high or low pressure switches are OFF longer than 10 minutes</li> <li>high or low pressure switches are OFF 5 times per 10 minutes</li> </ul> In both cases, the unit will switch to the Ventilation Mode. If the Red Alarm appears, alarm code is shown on the display.
				The Yellow Alarm (WARNING) symbol will shine in case of temperature sensor failure. If the Yellow Alarm appears, alarm code flashes 5 times on the display. To restart the unit, press the ON/OFF button (1) twice to switch the unit OFF and ON. If the alarm comes up again, don't restart and see your nearest dealer for service.
2.		Mode select button (MODE) (ESCAPE)	<b>auto</b>	Reheat/Auto mode. The unit will cool or heat the bus automatically (according to thermostat requirements). This function is optional and is not included in this vehicle.
				A/C mode. The unit will operate in cool mode.
				Heating mode. The unit will operate in heating mode. This function is optional and is not included in this vehicle.
				Ventilation mode Only the blowers are operating.
3.		Temperature button (UP)	Use to increase/ decrease temperature setpoint.	
		Temperature button (DOWN)		
4.		Blower speed button (SPEED) (ENTER)	<b>auto</b>	Automatic blower speed The blowers are controlled automatically depending on the thermostat setpoint and passenger compartment conditions.
				High blower speed
				Medium blower speed
				Low blower speed
5.		Fresh air select button (AIR MODE) (SMOG)	<b>auto</b>	This function is optional and is not included in this vehicle.
			1/2	

6.		Display		Return air temperature icon
				Setpoint icon
				Red - Boost pump icon
				Blue - Compressor clutch icon

**Operating Instructions**

Turn the system ON by pressing button ON/OFF (1).

Use the buttons MODE, SPEED, AIR MODE and DOWN and UP to adjust the system. By pressing the selection button you select one of the options in the same group.

Use the DOWN button to set lower setpoint temperature (down to Lo = full cooling independent on real temperature). Use the UP button to set higher setpoint temperature (up to Hi = full heating independent on real temperature).

In Auto Mode all functions are controlled by the ClimaAIRE I D controller automatically according to the required setpoint.

Turn the system OFF by pressing button ON/OFF (1).

## TIPS ON SAFE DRIVING

### DRIVING SAFELY

#### GET PLENTY OF REST



If you drive when you are tired, you will get sleepy and lose concentration. Please get plenty of rest before you drive.

#### TAKE BREAKS DURING LONG JOURNEYS

Driving long distances is tiring. Please take rest breaks from time to time.

### ON THE ROAD

#### CAUTIONS FOR DRIVING



- Concentrate on driving safely, obeying all legally designated speed limits, road signs and traffic signals.
- Do not place the starter switch to any position other than the "ON" position while driving. The power steering would stop working, making steering extremely difficult. Also, the brakes would not work well, putting you in extreme danger.
- If you notice any abnormal noise, abnormal smell or abnormal vibration from any part of the vehicle, immediately stop the vehicle in a safe place and perform checks.
- If a warning light comes on or a buzzer sounds while you are driving, immediately stop the vehicle in a safe place and

perform checks.

- Slow down sufficiently when approaching a curve. Applying the brakes or sharply turning the steering wheel while turning the curve could cause the cargo to shift, the tires to slip and the vehicle to tip onto its side.
- While driving, do not place your hand on the gearshift lever except when changing gears. Doing so could cause the transmission to fail.
- Avoid scraping the tire sidewalls against curbstones or driving over dips and protrusions in the road surface. You could damage the tires, resulting in a blowout or flat tire.



---

## BRAKE OPERATION

The brakes give strong braking force with only light pressure on the pedal. Do not press the brake pedal hard except in the event of an emergency.

---

### Model with Full-Air Brake System

1. Braking distances vary according to the vehicle speed and road conditions. First, slow down sufficiently using the engine brake and the exhaust brake.
2. Press the brake pedal and keep it pressed until just before the point at which you want the vehicle to stop.
3. Ease off the brake pedal.
4. Immediately before the point where you want the vehicle to stop, gently press the brake pedal to bring the vehicle to a halt.

### CAUTION

- Do not allow the brake pedal to fully return. If you allow the brake pedal to fully return, there will be a short delay before the brakes start to work the next time you press the pedal, meaning that the stopping distance may be increased.
- Unnecessary frequent depression and release of the brake pedal reduces the vehicle's air pressure, thereby detracting from brake effectiveness.

---

### Stopping distance



The vehicle's stopping distance consists of a reaction distance (from the point where the driver senses danger and presses the pedal to the point where the brakes start to work) and a braking distance (from the point where the brakes start to work to the point where the vehicle comes

to a halt). When driving, bear the stopping distance in mind. Maintain a speed and headway distance that allow you to stop safely even if a hazard occurs.

---

## MAINTAINING A CLEAR FIELD OF VIEW

---

### If the Windshield Fogs Up

Use the heater to blow hot air on the windshield or dehumidify the cabin using the air conditioner and place the vent knob in the  position. Place the inside/outside air selector in the outside-air position. Also, use commercially available antifog spray.

---

### Night Time Visibility

If there is an oil film on the windshield, the lights of oncoming traffic will be reflected in many directions, making it hard for you to see ahead. Use glass cleaner to clean the glass and the wiper blades.

### NOTE

- Worn wiper blades cannot wipe the windshield clean and thus cannot maintain visibility. When the wiper blades become worn, replace them with new ones.

---

## DRIVING AT NIGHT

Nighttime driving is more dangerous than daytime driving because the field of view is narrower. Keep your speed down, and maintain an ample headway distance.

---

## DRIVING IN FOG

Turn on the fog lights and drive slowly, using the road's center line as a guide. It is dangerous only to follow the lights of the preceding vehicle because they can cause optical illusions. Drive with caution.

---

## HIGHWAYS

1. Speeds on highways are higher than those on regular roads, so there is more danger. Also, a breakdown on a highway represents a hazard to other vehicles and can cause an accident. Concentrate on safe driving. Remember to perform daily pre-operation inspections and use highway driving techniques. When performing daily pre-operation inspections, perform the checks shown in the table on the left with particularly great care.
2. When merging with traffic on a highway, use the turn signal lights to indicate your intentions ahead of time. Speed up sufficiently when you are in the acceleration lane. Pay attention to vehicles behind you and to conditions in the lane you are joining. Merge in such a way that you do not obstruct vehicles in the lane.
3. Your sense of how fast you are traveling becomes distorted on long highway drives. Constantly keep an eye on the speedometer, and maintain a suitable headway distance.
4. During high-speed driving, even a little turn of the steering wheel causes a big movement of the vehicle. Turn the steering wheel slowly.
5. Excessive use of the brake pedal is extremely dangerous because it rapidly wears the brake linings and causes brake fade. Make effective use of the engine brake and (if your vehicle is so equipped) the exhaust brake when you wish to decelerate.
6. When you wish to turn off a highway, use the turn signal lights to indicate your intentions ahead of time. Paying attention to vehicles behind you, turn off the highway smoothly so as not to obstruct other vehicles.

## NOTE

- Frequent use of the brakes can cause the brakes to overheat so that the frictional force of the brake linings decreases and the brakes become less effective than normal. This phenomenon is called brake fade.

---

## DRIVING ON SNOWY OR FROZEN ROADS

### CAUTION

- On slippery roads, never accelerate rapidly, brake hard, decelerate rapidly or make sharp turns of the steering wheel.
- There is a risk of reduced grip between the tires and road surface and of increased braking distances. The danger of icy road surfaces is particularly great on bridges, in shady places and where there are puddles. Keep your speed down and be sure to use tire chains or winter tires on snowy or frozen road surfaces.
- Use lower gears to overcome the retardation effect of the engine. Apply the foot brakes lightly.

### ADVICE

- With a Smoother vehicle, you can make a standing start in the manual-mode 3rd gear if you first hold down the brake pedal and move the gearshift lever to the "+ (upshift)" position.

### NOTE

- For models that are equipped with anti-slip regulator (ASR), when you want to free the vehicle from snow where the tires may slip slightly by increasing the engine speed, you can press the ASR OFF switch to disable the ASR.
- For models that are equipped with electronic stability control (ESC) and the ESC OFF switch, when you want to free the vehicle from snow where the tires may slip slightly by increasing the engine speed, you can press the ESC OFF switch to disable just the anti-slip regulator (ASR).
- For safe driving, it is recommended to disable the retarder/intarder on slippery roads. For this, the outpatient retarder application can be disabled with the "retarder enable" button.

---

## BEFORE DRIVING IN COLD REGIONS

---

### Getting In and Out of the Vehicle

The step can get icy in cold regions. Be careful not to slip when getting in and out of the vehicle.

---

### Before Sitting in the Driver's Seat

Remove snow and ice from your shoes when getting into the vehicle. If you try to drive with snow on your shoes, your shoes would slip on the pedals and you would not be able to press the pedals properly, meaning that your driving would be inconsistent. Also, the cabin could become more humid, causing the glass to fog up.

---

### Starting the Engine

When you start the engine, check that the accelerator pedal works smoothly.

### NOTE

- For Smoother models, when the ambient temperature or the temperature inside the garage is lower than -25°C, the transmission needs to be warmed up in addition to the engine. To start the engine and operate the transmission correctly, warm them up sufficiently.

---

## **DRIVING ON SNOWY OR FROZEN ROADS (FENDERS)**

### **CAUTION**

- On snowy roads, water and snow splashed up by the tires can freeze and accumulate inside the fenders, making the steering wheel hard to turn. From time to time, get out of the vehicle and remove any accumulated snow. Do not use a sharp implement to remove the snow. Sharp edges could damage rubber parts.
- When the vehicle is driven or parked on a snowy surface, ice can form on the brakes, decreasing their effectiveness. From time to time while you are driving, press the brake pedal lightly and check the brake's effectiveness. Pay attention to vehicles both ahead and behind you when checking the brakes in this way.
- Also, check the brake's effectiveness as soon as possible when starting to drive the vehicle after it has been parked. If the brakes do not work well, drive slowly and gently press the brake pedal several times until the brakes dry out and start working normally.

---

## **REMOVING SNOW FROM THE GLASS AND UNDERBODY**

To maintain an adequate field of view, use a plastic scraper to remove snow and frost from the glass surfaces. By using a plastic scraper, you can remove the snow and frost without scratching the glass. At this time, check whether the wiper blades are frozen onto the glass. Also, look under the vehicle and remove any lumps of ice that are stuck to the underbody. Be careful not to damage components.

### **ADVICE**

- Do not use a sharp implement to remove snow. Sharp edges could damage rubber parts.

---

## **DRIVING ON POOR ROAD SURFACES (SAND OR MUD)**

If the vehicle gets stuck in mud, pressing the accelerator pedal more than necessary will simply dig the vehicle deeper into the mud and make it harder to extricate. Either put stones, tree branches or blankets under the tires to gain traction or repeatedly drive forward and backward to use the vehicle's momentum to extricate it.

When you cannot avoid driving through deep mud, using tire chains is an effective way to avoid getting stuck.

### **ADVICE**

- When driving in sand or mud, avoid hard braking, sudden acceleration and sharp turns of the steering wheel. Such actions could get the vehicle stuck and make it impossible to extricate.
- After driving through deep mud, any mud stuck to the vehicle can harm the steering, brakes and powertrain. Wash the vehicle and remove all mud and other incrustation.
- On anti-lock brake system (ABS) equipped model, the vehicle speed sensors are fitted on the wheels. When removing mud and other incrustation, take great care not to damage the components.
- Do not use a sharp implement to remove mud. Sharp edges could damage rubber parts.

### **NOTE**

- For models that are equipped with anti-slip regulator (ASR), when you want to free the vehicle from mud where the tires may slip slightly by increasing the engine speed, you can press the ASR OFF switch to disable the ASR.

## CAUTIONS FOR DRIVING IN HOT REGIONS

The engine will be prone to overheating in an environment where the ambient temperature is high. To prevent the engine from overheating, pay attention to the following points:

### CAUTION

- Do not put well water, river water or other hard water in the engine cooling system. It would hasten the formation of rust and scale.

If foreign matter (insects, mud, etc.) gets stuck in the radiator's air passages, the cooling system's performance will deteriorate. Check the air passages for clogging, and remove any foreign matter using water under low pressure.

### ADVICE

- When the ambient temperature is high, evaporation of battery fluid will become quicker. Frequently check the battery fluid level and, when necessary, add more fluid.

## CAUTIONS FOR DRIVING IN COLD REGIONS

The following cautions apply to snowbound regions and to mountainous regions, ski resorts and other areas of extreme cold and/or snowfall. Please use them also for reference in winter in other regions.

For the sake of your vehicle, have your Isuzu Dealer make the winter preparations described hereafter. Also have these preparations made before driving to a cold region.

### CAUTION

- Do not cover the front of the radiator with newspapers, cardboard or any other flammable material to raise the engine coolant temperature.
- If you allow the engine to warm up but the engine coolant temperature does not rise, have the nearest Isuzu Dealer inspect the thermostat.
- If you park in a place where there is a lot of snowfall, snow accumulating around the vehicle could limit ventilation. Running the engine with the vehicle in such a situation could cause exhaust gases to enter into the cab, resulting in carbon monoxide poisoning. Take preventive action by, for example, clearing the snow around the vehicle.

---

## PROTECTION OF ENGINE AGAINST OVERCOOLING

Overcooling of the engine not only accelerates wear of the vital engine parts but also deteriorates fuel economy.

---

### COOLANT

To prevent the engine damage due to freezing of the engine coolant, mix the coolant and water at a ratio of 50/50. Replace damaged rubber hoses as the engine coolant becomes liable to leak even past minor cracks when the engine coolant solution is used.

---

## REPLACING THE ENGINE OIL

The engine oil tends to harden with lowering temperatures. Use engine oil with a viscosity suited to ambient temperature.

---

## UREA®

### ADVICE

- Urea® freezes at a temperature of -11°C. Since the urea SCR system is equipped with a heating function that utilizes the engine coolant, the engine will start even when urea® is frozen.

### CAUTION

- Do not warm up the urea® tank using burners or heaters.

---

## WHEN ICE PREVENTS YOU FROM OPENING THE DOOR

If you try to force the key into the door, you could bend it. And if you try to pull the door open with undue force, the rubber seal around the door could come unstuck or become damaged. Use warm water to melt the ice, then quickly wipe it away and open the door.

If the wipers, electric door mirrors, or power windows freeze up, also use warm water to melt the ice and then operate the system. Otherwise, you could damage the mechanism and drain the battery. After that, wipe the water away.

---

## WINTER TIRES

Use winter tires of the same sizes as the standard tires. Also, use wheels of the same size as those with the standard tires. A winter tire has reached its wear limit when the tread grooves have worn to half of the depth of the new tire. At this time, platforms indicating that the tire can no longer give adequate performance on snow become visible in the grooves. Replace the tire with a new one.

### CAUTION

- Avoid sharp turns of the steering wheel and hard braking. Use the engine brake to decelerate. When applying the brakes on snowy or frozen road, lightly press the pedal several times rather than giving it one hard press. A single hard press of the pedal would be dangerous because it could cause the vehicle to slip or skid.
- If your vehicle is equipped with an exhaust brake, and you use the exhaust brake on a slippery road when the vehicle is not loaded, the resulting hard deceleration can cause the back of the vehicle to swing sideways. Exercise caution.
- Avoid driving at high speeds on a dry road with winter tires.
- Comply with local legal requirements when using winter tires.

---

## CLEANING THE VEHICLE AFTER DRIVING ON SNOWY ROADS

### CAUTION

- Remove snow that has stuck to the inside of the fenders and to the brake hoses. Otherwise, it may damage components. After driving on a salted road, wash the underside of the vehicle as soon as possible to prevent the salt from causing rust. Spraying water under high pressure is an effective way to get the salt off.
- After washing the vehicle, wipe the door openings dry.

### NOTE

- On anti-lock brake system (ABS) equipped model, the vehicle speed sensors are fitted on the wheels. When removing snow, ice and other incrustation, take great care not to damage the components.
- Do not use a sharp implement to remove snow. Sharp edges could damage rubber parts.

**DRIVE SUPPORT SYSTEMS****TPMS (Tire Pressure Monitoring System)**

Transmits tire pressure information to the driver. TPMS warning,

- If any tire pressure is 20% below the nominal pressure,
- If any tire pressure is 25% above the nominal pressure,
- When a tire without a sensor is installed,
- When the sensor battery level is low,

It informs the driver.

During tire or wheel changes, the sensors on the wheels must be installed on the same wheel. If multiple sensors are replaced, the TPMS sensor registration process must be performed. The battery life is approximately 7 years. Tire changes must be performed at ISUZU authorized service centers. Interventions performed outside of an authorized service center may prevent the TPMS from functioning properly. If there is an error in the sensors or the system, a red warning light will illuminate.

**DDAW (DRIVER FATIGUE DETECTION SYSTEM)**

When the vehicle speed is above approximately 60 km/h, the system calculates the driver's attention level based on their behavior. The system analyzes whether driving has deteriorated and alerts the driver to take a break. It consists of a two-stage warning system:

- A warning is issued recommending that you take a break. This remains on the instrument panel until you cancel it. If you do not take a break and the system continues to detect that your driving has deteriorated, it will permanently display the fatigue icon, which will remain until you turn off the vehicle.

Since the system operates in conjunction with cameras and sensors:

- If the camera and sensors are obstructed or damaged, the system may not function properly,
- The system may not function properly on roads where lanes cannot be read or are uneven,
- The system's performance may vary depending on weather or environmental conditions (rain, light, etc.).

The fatigue detection system can never definitively determine the driver's actual fatigue level. If you feel tired or distracted, you should rest. Vehicle control and safety are always the driver's responsibility.

**ISA (Intelligent Speed Assistant)**

When the specified speed limit is exceeded, the driver is given a visual and audible warning.

- The function works in conjunction with GPS and camera.
- The driver is given information about the speed limit on the route.

**LDWS (Lane Departure Warning System)**

This system alerts the driver with optical and acoustic warnings when the vehicle exceeds the speed limit of approximately 60 km/h and drifts out of its lane.

The system does not function when radar sensors are obstructed (e.g., by snow, mud, or dirt). Sensors do not replace safe driving; they are systems developed to assist the driver during driving. Systems may not function as expected in certain situations. Driving safety and attention requirements are the driver's responsibility.

- On roads where lanes cannot be read properly,
- When the vehicle is traveling below approximately 60 km/h,
- During sudden braking or lane changes,
- In cold, foggy, or severe weather conditions,
- In dense or low light and glare,
- When ABS, ESP, or ASR systems are activated,
- On uneven road surfaces and sharp curves,

The system may not function properly.

**ADVANCED EMERGENCY BRAKING SYSTEM (CMS) - OPTION**

The Advanced Emergency Braking System is a system that automatically detects an emergency situation and activates the braking system to slow down the vehicle in order to avoid a collision or reduce its impact. It provides at least two warnings before braking, at least one of which is acoustic.

The CMS's operating speed range is set at 7-120 km/h. At speeds below or above this range, it will deactivate and enter "Temporarily Out of Service" mode.

The standard sequence of a full CMS reaction is as follows:

- Start of visual and audible warning (FCW)
- Application of haptic feedback (HCW)

CMS will not function properly if the following items are not observed:

- Do not alter the position of the radar or the radar cover.
- Do not paint the radar cover.
- Do not replace the radar cover.
- Do not place objects (plates, labels, bike racks, etc.) on or in front of the radar cover.

If CMS is not deactivated in the following situations, the vehicle may brake on its own, creating a dangerous situation:

- If the vehicle is towed while the ignition is on
- If the vehicle enters a mechanism where the wheels rotate while in a stable position
- If the vehicle is lifted off the ground by the front or rear axle, causing the wheels to rotate

The CMS system may not function properly under the following conditions:

- When the radar cover is muddy, wet, covered with snow, or icy due to weather conditions
- When the radar cover is damaged
- When there are reflections from the surroundings in tunnels
- When the vehicle cannot detect the vehicle ahead while turning

The CMS system does not apply brakes to objects such as toll booths or concrete blocks that do not reflect on the road.

### **MOTION START INFORMATION SYSTEM (MOIS)**

The system becomes active when the vehicle is traveling at approximately 0-15 km/h. In accordance with UN ECE R159 regulations, it only provides warnings for cyclists and pedestrians. The function does not work when the vehicle is in reverse gear.

- The function is active when the vehicle speed is between 0-15 km/h.

When objects enter the scanning area;

- The speed of parallel-moving objects must be between 2-7 km/h,
- The speed of vertically moving objects must be between 0-12 km/h, to be detected.

MOIS may not function properly under the following conditions:

- When in reverse gear (R) or when the vehicle speed is approximately 15 km/h or higher, or when the vehicle is stationary,
- When objects in front of the vehicle are moving too close or too far from the vehicle,
- When objects are stationary or moving too quickly,
- If the sensors are obstructed by dirt, snow, mud, or an external cause, or if they are damaged,

The MOIS warning system should be turned off from the driver's display screen under the following conditions.

- If there is a load attached to the front of the vehicle (bike rack, etc.),
- If the vehicle is towing another vehicle or being towed by another vehicle,

### **BLIND SPOT WARNING SYSTEM (BSIS)**

The blind spot warning system has been developed to detect road users such as pedestrians, cyclists, and vehicles in the field of view of BSIS radars on the side of the truck. In accordance with UN ECE R151 regulations, 2 BSIS (right) and 1 MOIS (front) radars are used as standard in vehicles.

The blind spot warning system detects pedestrians, cyclists, and other road users entering or about to enter the vehicle's blind spot and alerts the driver. By default, it monitors the right side of the vehicle, and if desired, the left-side blind spot area can also be included. Warnings are triggered when the object or vehicle is moving in the same direction.

The system alerts the driver with optical and acoustic warnings from the blind spot warning light on the passenger side. In situations where the system detects a collision risk, the driver is alerted with an icon on the display screen and optical and acoustic warnings.

- The function is active when the vehicle speed is between 0-30 km/h.
- The collision warning is not active when the vehicle is stationary.

When objects enter the radar scanning area;

- Cyclist speed must be between 5-20 km/h,
- Pedestrian speed must be between 2-20 km/h.

The blind spot warning system may not function properly under the following conditions;

- When in reverse gear (R) or the vehicle speed is approximately 30 km/h or higher, or the vehicle is stationary,
- When sensors are obstructed by external factors such as dirt, snow, mud, foil, or a different cover,
- When a vehicle enters the sensor detection area at high speed,
- When sensors or sensor covers are damaged,
- If there is an immobile or very slowly moving vulnerable road user (VRU) in the detection zone,

**PLCA (PASSIVE LANE CHANGE ALERT) - OPTION**

The PLCA function alerts the driver to vehicles (cars, motorcycles, trucks, etc.) approaching from behind in the adjacent lane.

- The LCDA warning is activated when the specified objects are moving in the same direction as the vehicle.
- The minimum vehicle speed required for the function to activate is 43 km/h.

The speed limits required for the function to activate on the target object are:

- Minimum target vehicle speed: 21 km/h,
- Minimum relative speed -22 km/h (example: vehicle speed 43 km/h, target vehicle speed 21 km/h),
- Maximum relative speed 36 km/h (example: vehicle speed 50 km/h, target vehicle speed 86 km/h), must be met.

**FUNCTION - MODULE NAME**

**ACTIA**

**BSIS**

**Only "Audible and Visual Warning" can be selected from the menu, and this selection cannot be turned off.**

**Proximity warnings are indicated by a warning light located on the right A-pillar. (No audible warning.)**

**In the event of a collision, the following warning appears on the vehicle's cluster display. (An audible warning is given as long as the collision warning is active.)**



# MOIS

When "Audible and Visual Warning" is selected from the menu;

Proximity warnings are displayed in the cluster as follows. (The icon makes a sound when it appears and

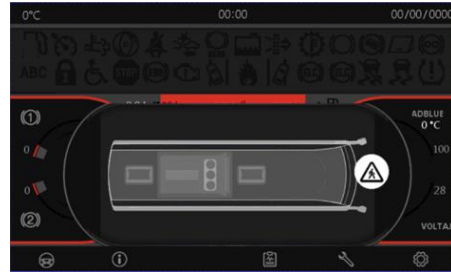

Collision warnings are displayed in the cluster as follows. (An audible warning is given when a collision warning is received.)



When "Alerts Off" is selected from the menu, the MOIS system shuts down and a passive alert appears on the radar screen.



PLCA

N/A

## DDAW

If "Sound On" is selected in the menu, and the vehicle speed exceeds 70 km/h, and lane departure occurs three times within one minute, or the steering angle micro-movement approaches zero continuously for 4.6 seconds or intermittently for 6 seconds,

The coffee icon is displayed for 10 seconds (continuously), and the buzzer sound remains active for 3 seconds from the parking sensor module. If the vehicle speed remains above 0 km/h intermittently or continuously for 3 hours, the coffee icon remains on the screen until the vehicle is turned off.

If "Sound Off" is selected in the menu, the buzzer sound is disabled, and only the coffee icon is displayed.



If there is a fault in the DDAW system (LDWS or steering angle sensor problem), a crossed-out coffee icon is displayed.



## TPMS

If a drop in pressure is detected in one or more tire pressures, the following icon is displayed on the HMI screen.



## CYBER SECURITY

If the Cyber Security System is deactivated in the vehicle, the following icon is displayed on the HMI.



If the Cyber Security System detects a cyber attack on the vehicle, the following icon is displayed on the HMI.



## ISA

If the vehicle speed exceeds the detected speed limit, the visual indicator will blink for 10 seconds and the buzzer will sound continuously for 4 seconds.

If "Mute Audible Warning" is selected in the menu, the buzzer will be muted and only the speed icon will be displayed. If the vehicle speed exceeds the detected speed limit, the visual indicator will blink for 10 seconds and no audible warning will be given.

If "Visual Warning Off" is selected in the menu, the blinking is turned off, and only the speed icon is displayed. If the vehicle speed exceeds the detected speed limit, an audible warning is given for 4 seconds.



If "Turn Off Audible Warning" and "Turn Off Visual Warning" are selected at the same time from the menu, the speed limit information is displayed directly without blinking, regardless of the vehicle speed. No audible warning is given. If there is an interruption in the camera system or GPS data, an exclamation mark is displayed next to the speed limit icon.



If "System Closed" is selected from the menu or there is a malfunction in the camera system, the following icon is displayed.



SERVICE AND MAINTENANCE

BEFORE SERVICE AND MAINTENANCE

PRECAUTIONS FOR CHECKING AND ADJUSTMENTS

WARNING

- Make sure to turn off the engine and remove the key from the starter switch before performing any checks.
- Pull firmly on the parking brake lever and put the transmission in neutral.  
- If your vehicle is equipped with a A/T system, place the gearshift lever in "N" and make sure the shift indicator displays "N" (for Smoother models with P-range, place the gearshift lever in the "P" position and check that the shift indicator displays "P").
- Select a place with a solid and level surface to perform the checking and maintenance work. Make sure to chock the wheels. It would be very dangerous if the vehicle started to move.
- To prevent personal injury, keep hands, tools and clothing clear of the engine cooling fan when the engine is running.
- When raising the vehicle, use a suitable jack, not the one provided on the vehicle.
- After raising the vehicle and before going underneath to perform work, make sure the vehicle is supported with jack stands.
- When performing work on the electrical system, begin by turning the starter switch to the "LOCK" position, wait at least 3 minutes (models with SCR) or 2 minutes (models without SCR), and then disconnect the negative cable from the negative terminal on battery. If the negative cable is disconnected within 3 minutes (models with SCR) or 2 minutes (models without SCR), the engine control module may malfunction.
- The engine, exhaust pipe and radiator will be hot immediately after the vehicle is driven. Be careful around these parts to prevent burns. Perform all checks when the engine is cold.
- Do not perform work near an open flame or other heat sources.
- When working on the fuel line or fuel filter, remove the fuel tank filler cap. The fuel system is under pressure and the fuel will overspill unless the pressure is relieved, possibly leading to combustion or a fire.
- Do not let the engine run in poorly ventilated garages or sheds. This could cause carbon monoxide poisoning.

CAUTION

- Discarded parts, oil, grease and fluids could have an adverse effect on the environment. It is difficult to dispose of these, so have your Isuzu Dealer handle all checks and replacements.

## ADVICE

- Use only appropriate tools.
- Oils, brake fluid, battery fluid and engine coolant have lubrication, cooling and rust prevention functions. If these liquids deteriorate through loss or contamination, it will cause a decline in the performance of the parts and such problems as seizure or malfunctioning. Replenish or change these liquids when performing the checks (daily and periodic checks) as required by the relevant regulations or in accordance with the Maintenance Schedule (when either the specified driving distance or period of time, whichever comes first, has expired).
- Confirm that all systems and components are normal after performing the work.
- Do not leave the removed parts or tools in the engine compartment. They could damage the equipment if caught in the belts or other moving components.
- Dirty water, dirt and other impurities seriously impair the effectiveness of the oil, grease and fluids, and damage the parts. Exercise all due caution to prevent waste or other refuse from coming in contact with parts or materials that have been removed when changing or replenishing them.

---

## DISCARDED PARTS, OILS AND OTHER LIQUIDS

- When changing oils, filters, engine coolant or other liquids, be sure to have a container ready in advance for their disposal.
- Use methods conforming to legal requirements for discarding or disposing of parts, oils, filters or engine coolant after change or replacement.

---

## GENUINE OILS AND GREASE

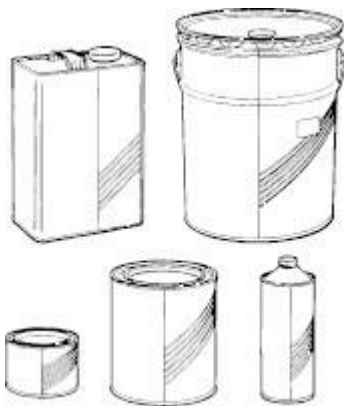

Periodically replenishing and changing the oil and grease is extremely important for maintaining your vehicle's performance and preventing malfunctions.

### CAUTION

- Flames or other heat sources near spilled oil can cause a fire. Make sure to clean up all oil spills.

**DAILY CHECKS**

Check your vehicle for the items listed below before starting the day's operation to ensure safe, trouble-free operation. Also, make note of the distance the vehicle has covered and the conditions under which the vehicle has been operated to be able to determine the inspection intervals most appropriate for your specific vehicle and adequately service it according to inspection results.

If the checks reveal an abnormality or if there are components that showed abnormalities during the previous operation, have the vehicle repaired by your Isuzu Dealer before using the vehicle.

**DAILY CHECKS**

Daily Inspections Check List:

1. Checking components that showed abnormalities during the previous operation
2. Fan belt looseness and damage
3. Engine oil level
4. Transmission oil level
5. Engine coolant level
6. Power steering fluid level
7. Brake fluid level
8. Brake pedal free play
9. Increase in air pressure
10. Operation of meters, gauges and warning/indicator lights
11. Engine start ability, abnormal noise and color of exhaust gases
12. Parking brake lever stroke
13. Windshield washer fluid spray condition and windshield wiper effectiveness
14. Windshield washer fluid level
15. Steering wheel free play and mounting condition
16. Operation of horn and turn signal lights
17. Fuel level
18. Illumination, flashing or damaged lights
19. Battery fluid level
20. Condensation in air tank
21. Leakage of oil, engine coolant, fuel, brake fluid, power steering fluid
22. Water collecting in the fuel filter
23. Air pressure
24. Cracks and other damage
25. Abnormal wear
26. Tread depth of tyres
27. Disc wheel mounting condition
28. Brake effectiveness
29. Checking the engine at low speeds and acceleration

---

## ENGINE-RELATED SERVICE AND MAINTENANCE

---

### ENGINE CONDITIONS

---

#### Checking the Engine for Start ability and Abnormal Noises

1. Make sure the parking brake is securely engaged. Step firmly on the brake pedal.
2. Make sure the transmission is in neutral.
3. Turn the starter switch to start the engine.

Check that the engine starts quickly with no abnormal noises.

#### CAUTION

- If your vehicle is equipped with the A/T system, the engine will not start unless the transmission is actually in neutral.
- For safety, firmly press the brake pedal before starting the engine.

---

#### Checking Condition of the Engine at Low Speeds and during Acceleration



1. Make sure the transmission is in neutral and the parking brake is securely engaged.
2. Turn the starter switch to start the engine, and run it to warm up.
3. Check that the engine is running at a speed within the standard idle speed range.
4. Drive the vehicle, making sure the accelerator pedal does not stick when gradually accelerating, the engine speed rises smoothly and it does not knock.

#### NOTE

- For vehicles equipped with a diesel particulate diffuser (DPF), engine idling speed may rise during DPF regeneration.



---

## ENGINE OIL

### Replacement of Engine Oil

1. Bring the vehicle to a horizontal position
2. Run the engine till the cooling fluid reaches to 60 °C temperature
3. Turn off the engine
4. Remove the oil drain plug, pour the oil to the oil collection container (if the oil draining operation is performed as a service maintenance interval, remove the oil filter and replace it)
5. Replace the oil drain plug with a new sailing washer and tighten it with an 80 Nm torque.



Use a specified engine oil in fluid specifications.

6. Realize the oil filling operation from the oil filling collar on the valve cover
7. Open the cover, fill the amount of oil specified in the fluid specifications
8. After waiting 5 minutes for oil to reach the sump, check the oil level (H level) from the dipstick, close the cover.

### Oil Level Control

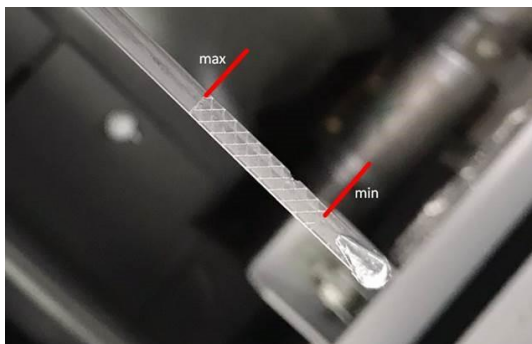

You can reach the oil level dipstick by opening the rear engine cap. For the control of oil level;

- Pull the dipstick
- Wipe with a clean cloth
- Replace the dipstick and pull again
- Check the oil level, fill it up to H level



If the oil level is slightly above the L level, supplementation must be done surely (in the vehicles which do not have oil complement system). The oil level should not reduce below L.

### AUTOMATIC ENGINE OIL REFILL SYSTEM (OPTIONAL)

Engine oil refill system is a system which completes the engine oil of the vehicle when it reduced. There is a 6 lt capacity oil tank in the engine area of the vehicle. When the ignition switch turned on after turned off for a time of 3 hours, the system controls the oil level automatically. When the engine oil of the vehicle reduces, the pump connected to the oil tank provides 0.5 lt oil supply to the engine.

There is a warning light  on the information display which alerts in the event of a failure during the supplementation of engine oil.

---

## ENGINE COOLANT

The engine cooling system is a device for keeping the engine temperature at an appropriate level.

The engine coolant must be changed according to the Maintenance Schedule.

### WARNING

- Check, replenish or change the engine coolant only after the engine has sufficiently cooled down.
- Do not loosen or remove the cap of the radiator or reserve tank cap when the engine coolant is still hot. Hot vapor or boiling water may burst out and cause a burn. Cover the cap with a cloth, etc. and remove it gradually after the engine is fully cooled down and the temperature of the engine coolant becomes low.
- When removing the reserve tank cap, use a thick cloth to cover the cap and turn it slowly.
- Engine coolant is toxic and must not be ingested. If the engine coolant is mistakenly ingested, immediately vomit it and seek prompt medical attention.
- If the engine coolant gets in your eyes, rinse it off immediately with a large amount of water for 15 minutes or longer. Also, if still abnormality such as irritation is felt, seek medical attention.
- If the engine coolant gets on your skin, rinse it off using a soap with a large amount of water. Also, if abnormality is seen, seek medical attention.
- Engine coolant is flammable, and therefore, it must be kept away from flames and other heat sources. Engine coolant also could ignite if it comes in contact with a hot surface, such as the exhaust manifold. Exercise caution to prevent this from happening.

### ADVICE

- Replace the engine coolant periodically.  
If the engine coolant is not replaced periodically, rust is generated due to degradation of the engine coolant, which may cause a failure such as water leakage, clogging of the radiator or heater core, or damage to the urea SCR system.

### NOTE

- Engine coolant is fluid which is made by mixing coolant and water at an appropriate concentration.

---

### Preparing Engine Coolant

To prevent the engine damage due to freezing of the engine coolant and to protect the cooling system from corrosion, mix the Isuzu recommended coolant and water to be at 50% concentration.

Cummins Filtration ES Compleat EG Premix 50/50 product is used in vehicles with Cummins and FPT engines.

## ADVICE

- Isuzu does not guarantee the use of the engine or vehicle at the outside temperature of -25°C or below.

## WARNING

- Coolant is toxic and must not be ingested. If the coolant is mistakenly ingested, immediately vomit it and seek prompt medical attention.
- If the coolant gets in your eyes, rinse it off immediately with a large amount of water for 15 minutes or longer. Also, if still abnormality such as irritation is felt, seek medical attention.
- If the coolant gets on your skin, rinse it off using a soap with a large amount of water. Also, if abnormality is seen, seek medical attention.
- For storage, close the cap securely and keep it in a place inaccessible to children.
- Coolant is flammable, and therefore, it must be kept away from flames and other heat sources. Coolant also could ignite if it comes in contact with a hot surface, such as the exhaust manifold. Exercise caution to prevent this from happening.

## CAUTION

- Use only an Isuzu recommended coolant.
- Using any coolant other than that Isuzu recommended could cause damage to the engine, radiator or heater core. In particular, use of coolants containing borate salts or silicates may result in engine, urea selective catalytic reduction (SCR) system, or radiator corrosion, causing engine coolant leaks and other problems.

## ADVICE

- To dilute the coolant, use distilled water or deionized water.
- Do not use the coolant at any coolant concentration other than that specified. If the coolant concentration is 60% or higher, overheating is likely to occur, while if it is 30% or lower, anti-corrosion function is not provided sufficiently.
- Using coolant at any coolant concentration other than that specified may reduce anti-freezing performance, and engine coolant may freeze.
- If the engine coolant decreases rapidly, go immediately to the nearest Isuzu Dealer for a check or repair.

---

## Checking the Engine Coolant Level

### Left Side Radiator Cap



Cooling unit, expansion tank water filling collar and level surveillance window can be reached by opening left side radiator cap.

---

## Adding the Engine Coolant

When the engine coolant level in the reserve tank is below the "MIN" line, open the tank cap and fill to near the "MAX" line with engine coolant. Tighten the cap securely after the engine coolant has been replenished.

### WARNING

- Check, replenish or change the engine coolant only after the engine has sufficiently cooled down.

### ADVICE

- Do not overfill the reserve tank.
- Check the reserve tank to determine engine coolant level. In situations, however, where the level in the reserve tank rises or falls suddenly, open the radiator cap and check the level within the radiator itself.
- When the engine is still hot, take care to prevent engine coolant from contact with the exhaust manifold. Any such contact could result in exhaust manifold damage.
- If the level of engine coolant changes rapidly, have your vehicle inspected at your Isuzu Dealer.



---

## Changing the Engine Coolant

9. Position the vehicle on a flat ground.
10. When there is a situation in which it is not necessary to run the cabin heater and A/C system, servicemaintenance is required, and the vehicle must be transferred to a place to start immediately, processes stated in the 12<sup>th</sup> and following articles must be applied.
11. Open the manual valves and air relief valves on the waterlines tied to cabin heater and A/C units (in the engine water Inlet and outlet).
12. Open the top and side caps of expansion tank.
13. Starts filling the engine cooling system fluid with the mixture of 50% antifreeze and 50% diluted water from the cap on the side surface of expansion tank.
14. When the expansion tank is full, stop filling. Wait for 1-2 minutes before starting the engine to make sure that air which entered in the system from natural ways is discharged and cooling fluid level is balanced. Then add water to the tank again.
15. Start the engine and open the entire heating system in the maximum position. Take the controller to manual maximum heating mode, quickly press the degree increasing key on the control panel to take to shocking mode and make sure that electronic three-way cock is open. System pump and heated A/C pump will be operating thus and there will be an "operating" signal on the A/C controller screen.
16. As the vehicle runs, keep adding engine cooling system fluid up to the maximum level of the expansion tank.
17. After starting a cool engine, gradually increase the engine speed to make sure that sufficient amount of oil goes to engine bearings and oil pressure is balanced.
18. For air relief, start the engine in raised idling speed and release the air from air release valves on the cabin heaters (System's air must also be relieved from the air relief valves on the heated cabin heater).
19. Check whether the cabin heater temperatures have risen. Total air relief for cabin heater and A/C system lasts for about 15 minutes. Make sure that air relief is completed.
20. Close the manual valves on the waterlines tied to cabin heater and A/C units (engine water inlet and outlet).
21. Restart the engine and run the engine at high speed until cooling water temperature has reached the thermostat opening temperature values. Radiator grille may be covered with a cloth (linoleum etc.) to reach the high temperature quicker.
22. It must be continued to run the engine at raised idle speed for 5 minutes and keeping the engine cooling water thermostat opening temperature (90-95°C) range once these temperatures have been reached.
23. Run the engine in low idle for 1 minute before shutting off, which enables components such as piston, cylinder, bearings and turbocharge to cool adequately.
24. Shut off the engine and keep adding cooling fluid up to the maximum level of the expansion tank.
25. Restart the engine at raised idling speed and increase the engine cooling water temperatures to thermostat opening temperature values 90-95°C range and keep this temperature level for 1 minute.

- 26.** Run the engine in low idle for 1 minute before shutting off, which enables components such as piston, cylinder, bearings and turbocharge to cool adequately.
- 27.** Shut off the engine and fill the cooling fluid if it is possible to fill from expansion tank. If 1 lt or more cooling fluid can be added to the system, repeat the operations from the 17th article.
- 28.** Check whether there is cooling fluid leakage in layout and main components during filling and air relief processes.
- 29.** It is the customer's responsibility to daily check the cooling fluid level and fill if required.

#### CAUTION

- Do not start the engine when engine coolant has been drained from the radiator. This could cause the engine to seize up.

#### ADVICE

- Tighten the radiator drain plug by hand. Tightening with pliers or some other tool could damage it.

#### AIR CLEANER

---



The air filter can be reached by opening the left rear side cover of the vehicle. The rubber dust valve below is used to discharge the accumulated dust by squeezing the edges in order to clean the air filter.

#### Air Filter Elements

The replacement of air filter elements must be realized every 30000 km, for replacement the steps below must be followed:

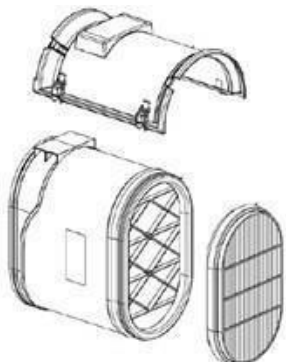

- 1.** Open the clips
- 2.** Remove the cap
- 3.** Remove the filter
- 4.** Separate the filter element
- 5.** Clean the air filter and cap
- 6.** Mount the new filter element
- 7.** Replace the filter and close the cap.

## FUEL FILTER

Change the fuel filter (both the chassis-side and engine-side fuel filters for vehicles with a pre-fuel filter) in accordance with the Maintenance Schedule. Drain the water when the water separator (fuel filter) warning light comes on.

### Water Separator (Fuel Filter) Warning Light



When a certain amount of water has collected in the water separator (the engine-side fuel filter), the water separator (fuel filter) warning light comes on. When this happens, drain the water and make sure that the warning light has gone out.

### CAUTION

- Water remaining that is not discharged from the water separator could freeze and damage the vehicle.
- If the warning light comes on while the engine is in operation, immediately drain the water from the water separator (fuel filter). Continuing to drive with the light remaining on could damage the fuel injection system. If this happens, have the vehicle checked and serviced by the nearest Isuzu Dealer.

## STEERING WHEEL HYDRAULIC TANK

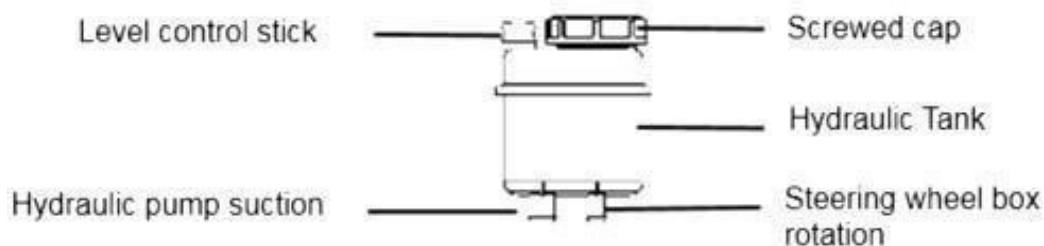

It is located at right side of the engine when the engine rear maintenance cap was opened. There is a screw cap and a dipstick available on the tank. Oil level control must be realized in every 3000 km. For oil level control, level dipstick of the tanks is removed, there is a minimum and a maximum line on the dipstick, the oil level must be between these two lines. The oil specified by the manufacturer of the vehicle must be used for the working of hydraulic steering wheel without problems. The vehicle must not be started if there is not enough oil in the steering wheel system, the steering wheel pump may damage. If the oil is reduced, it is supplied with oil up to the maximum line of the dipstick.

---

## AIR CONDITION COMPRESSOR BELT

---

Air condition compressor belts is V belt banded. When the belts damage or break, apply to the authorized service for change.

EXAMPLE IMAGE

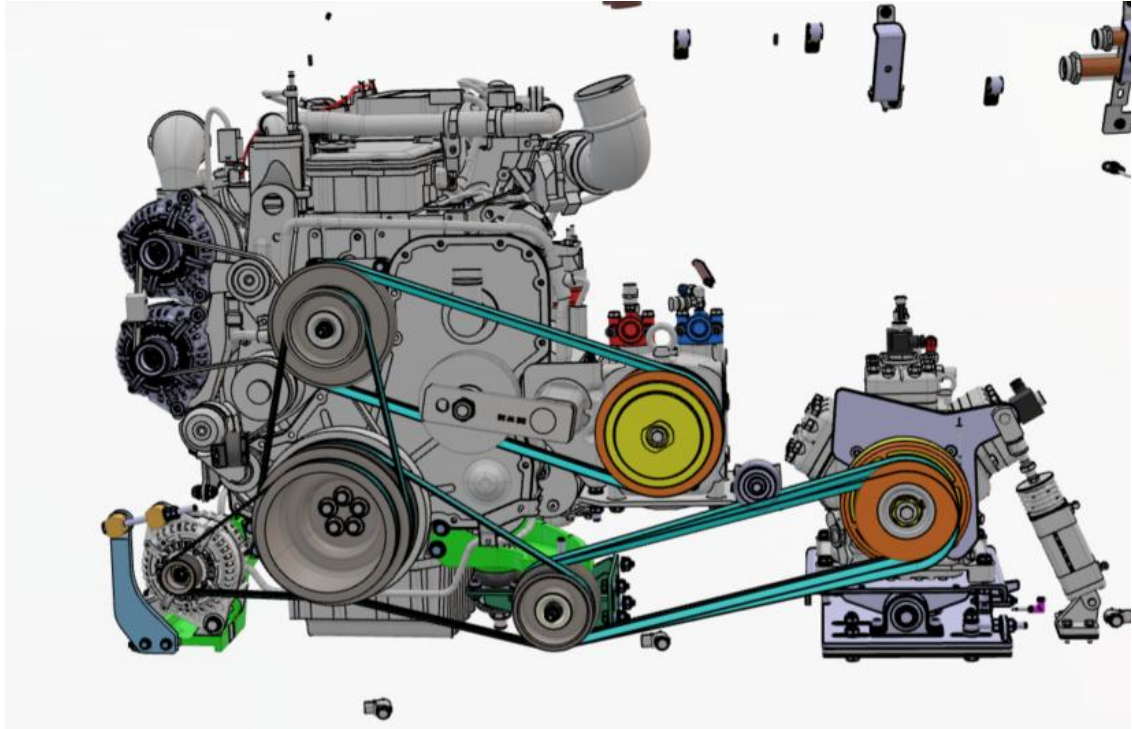

---

## CHASSIS-RELATED SERVICE AND MAINTENANCE

---

### BRAKES

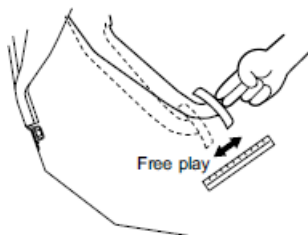

Shut off the engine and depress the brake pedal about 10 times strongly, then check the brake pedal for free play by lightly pushing it by hand until you feel resistance.

Run the vehicle slowly on a dry road and apply the brakes. Check that the brakes fully work and the vehicle does not pull on one side.

### CAUTION

- A brake performance check should be performed on a wide road with good visibility while paying adequate attention to the traffic behind and the surroundings.

---

### PARKING BRAKE

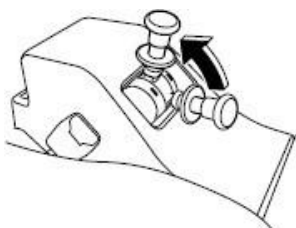

Pull the parking brake lever from the fully released position to the lever locked position to check that the air exhaust sound is heard and the lever stays in position. Also, on a dry sloping road, check that the parking brake can hold the vehicle stationary.

## WHEELS AND TIRES

The wheels have a major influence upon the safety and comfort of driving. Should any wheel fall off the vehicle, it not only causes the vehicle to break down on the road and block other traffic, but it may also lead to a serious accident. We strongly recommend that you check the wheels and tires daily and maintain them in satisfactory condition.

### WARNING

- Do not drive the vehicle unless the tires are properly inflated and in safe condition.
- If you find anything abnormal with wheel bolts, wheel nuts or disc wheels when you check them, avoid driving the vehicle and contact the nearest Isuzu Dealer as soon as possible.
- If you find anything abnormal on the left wheels, check the right wheels carefully for similar defects. A defect on a wheel may be a sign of defects on other wheels.

### Checking Tires

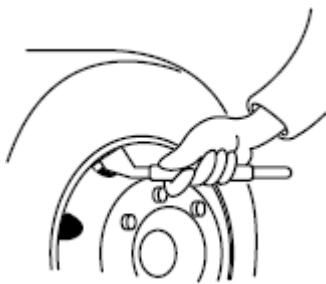

Too low or too high a tire air pressure not only affects the ride or causes damage to the cargo but also causes abnormal heat buildup, premature wear, a tire puncture, or may even cause the tire to burst.

Use an appropriate tire air pressure gauge when measuring the air pressure of a tire. Tire air pressure should be measured when the tire is cold, or before the vehicle is driven.

### WARNING

- Insufficiently inflated or worn-out tires are highly dangerous as they easily skid and can even burst. Should they burst, the tires may burn and this could cause a fire in the vehicle.
- If you drive on under-inflated or flat tires, the wheel bolts will be placed under excessive stress. Under such conditions, the bolts may break and the wheel may detach from the vehicle, possibly causing an accident.

### ADVICE

- There should not be a difference in air pressure between the inside and outside tires on a dual-tire wheel.
- It is not easy to visually identify an under-inflated dual-wheel tire or low aspect ratio tire (aspect ratio at 70% or 75%). Always use a tire air pressure gauge to check the air pressure of any tire.
- If your vehicle is equipped with aluminum wheels, use an extension attached to the inner tire valve together with a standard tire air pressure gauge or use a special air pressure gauge when checking the air pressure of a dual-wheel's inner tire. This facilitates checking.

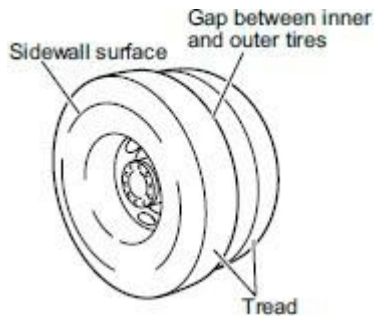

Check the tread and sidewall surfaces of each tire for cracks or other damage. Especially check the tread for nails or other metal pieces embedded in grooves and also the gap between the inner and outer tires of a dual-tire wheel for pebbles lodged in it.

**ADVICE**

- When checking tires, pay attention to: low air pressure; pebbles or nails in tread grooves; cracks or other damage on tiresurfaces; uneven wear; and pebbles lodged in the gap between

tires of dual-wheel tires.

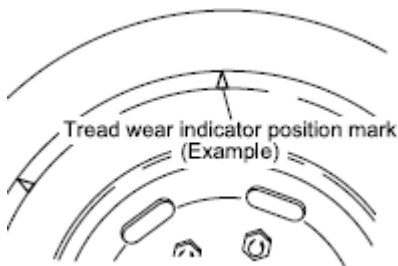

Using worn-out tires is dangerous because they might have an increased chance of getting punctured or bursting while driving. Check all tires to see if tread wear indicators appear on their treads and also check their entire tread for its depth with a depth gauge to make sure that the grooves are deeper than the specified depth.

A tire with tread wear indicators appearing must be changed. Also, check the tires for uneven or otherwise abnormal wear.

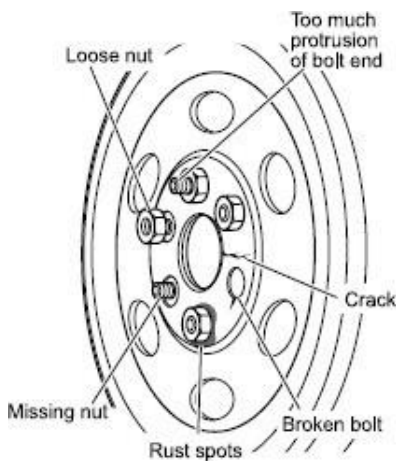

Visually check the condition of installation of each disc wheel.

1. Check that there are no missing wheel bolts and wheel nuts.
2. Check each disc wheel to see if there is any rust seepage from wheel bolts or nuts. Also check the disc wheel for cracks or other damage.
3. Check the end of each wheel bolt for proper length of protrusion from the wheel nut. The protrusion should be uniform among all bolts on a wheel and among all wheels.

---

## TIRE ROTATION

Tires at different locations wear differently. For uniform tire wear and longer tire life, you should rotate the tires on your vehicle regularly.

Make sure to use tires of the same type on the same axle. If you install tires of different types on the same axle, the vehicle may drift right or left when you apply the brakes. New tires are more likely to build up heat and wear faster than old tires, so they should be installed on the front axle where the load is smaller.

### CAUTION

- Your vehicle may be equipped with special tires whose direction of rotation is specified. A tire of this type has a set of arrows on the sidewall. The larger arrow shows the direction of rotation for forward movement of the vehicle. When installing the wheel assembly consisting of a tire of this type and a disc wheel, install the assembly so that the larger arrow points in the direction of rotation when the vehicle moves forward. (If the tread depth is 5 mm (0.20 in) or less when measured, it is possible to install the assembly so that the smaller arrow points in the direction of rotation when the vehicle moves forward. The tread depth can be checked with a depth gauge in either of the two center grooves among the four.)

---

## STEERING WHEEL

### Checking the Steering Wheel



While the engine is idling, place the steering wheel in the straight forward position, then gently turn it to the left and right by hand, and check the play in the steering wheel as the peripheral distance to the point where the tires start moving.



Grasp the steering wheel with both hands, and move it in the axial direction and also up and down, and left and right to see if there is any looseness.

Also, drive the vehicle and check for abnormal shaking of the steering wheel, steering pull, sluggish steering, or inability to return to the straight forward position.

---

## POWER STEERING FLUID

The power steering fluid level must be checked and it must be changed according to the Maintenance Schedule.

---

## HUB BEARING GREASE

As disassembly and reassembly will be required in order to replace front and rear bearing grease, have these operations performed by your Isuzu Dealer.

---

## GREASING CHASSIS COMPONENTS

The type (characteristics) of the grease specified for use with a chassis component differs from that of the grease specified for use with another component. Be sure to use only the specified grease for each component and perform greasing according to the Maintenance Schedule.

---

## AIR DRYER

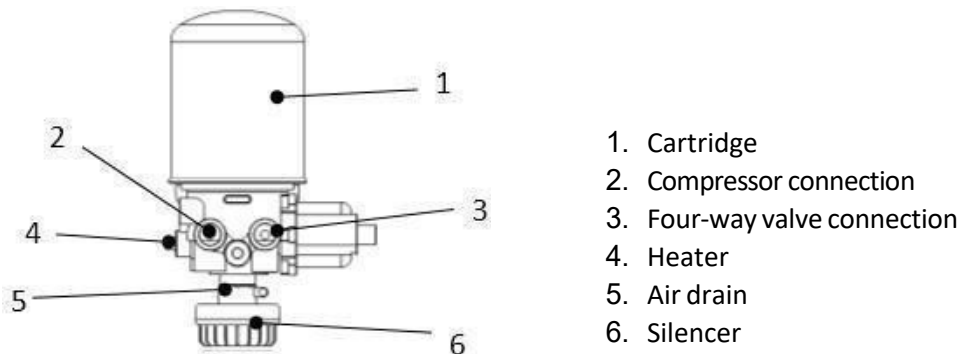

The air dryer is located on the front region of right rear wheel. The mission of the air dryer is to adjust the air pressure and to reduce the humidity and oil in the air pumped from the compressor. The dryer has the heater specification which prevents itself to freeze in cold weathers, this qualification activates in low temperatures, and breakdowns in high temperatures. The air dryer pumps air to the system at 9.8 bars until cut-off drain. After the filling has completed, the dryer throws out the accumulated water and oil from the silencer located under it. Thus, it cleans itself. The cartridge of the air dryer must be replaced after the usage of **1 year or 30000 km**.

---

**CORROSION & PREVENTIVE METHODS**

**What is Corrosion?**

Corrosion is a state of deterioration in metals (steel, copper, zinc, aluminum and their compounds) caused by oxidation or chemical action.

**Observation**

- Red rust in steel parts,
- White maculation on zinc parts,
- White maculation on Dacromet / Geomet coated parts,
- Green rust on copper parts,
- White maculation on aluminum parts.

**Causes of Corrosion**

**1- User Faults**

Nonobservance to the rules stated in user, workshop warranty & service manuals may cause corrosion.

- Noninterference to the scratches on the painted areas of the vehicle on time,
- Nonobservance to the preventive maintenance procedures,
- Nonobservance to the preventive actions before winter season

**2-Environmental Factors**

Environmental and geographical factors determine the corrosion factors.

- Hot and humid regions (e.g. seaside)
- Cold and snowy regions (road deicing)
- Cold and rainy regions,
- Industrial zones
- Additional applications to open the public roads (solid or liquid salt)

**Corrosion Zones**

Corrosion preventive methods can be applied into three main zones on the vehicle;

- A** ZONE A (Engine Compartment)
- B** ZONE B Chassis (Including luggage comp.)
- C** ZONE C Side Panels, and the rest of the vehicle



---

## CORROSIONS MAINTANENCE PROCEDURE

Each vehicle should be checked every 6 months. If the vehicle is not checked then it goes to out of warranty. If there is damage on vehicle, it must be repaired to avoid rust problem.

 CAUTION

Internal profiles should be checked annually, if wax has been removed, polishing<sup>one</sup> must be applied to the required structure of the hull with service approval.

 CAUTION

It is recommended to wash the vehicle at least once a week and to wash the underbody with low pressure water at least once a month in order to prevent the contamination from damaging the chemicals. High pressure water causes wear on the underbody lining.  
If any signs of corrosion are confirmed, should be rescheduled without delay.

 CAUTION

In winter, peeling and shedding should be checked 3 times on the underbody coating. Before the start of the winter season, at the end of January (when the high winter season is at the end of October), at the end of the winter season If there is wear, the coating<sup>2nd</sup> should be renewed where necessary

- 1: Candle: EFCOAT WH 492 A1
- 2: Underbody Coating HENKEL MS9320

 CAUTION

Vehicle should be check in 3 times a year.  
1st: Autumn maintenance should be done in October  
2nd: Winter maintenance should be done in January  
3rd: Spring maintenance should be done in April

## OTHER SERVICE AND MAINTENANCE

### HANDLING THE JACK

#### WARNING

- Raising the vehicle with a jack could lead to an accident when carried out on soft or inclined surfaces. Ensure that you always carry out this operation on flat, solid surfaces.
- Always apply the parking brake fully and correctly chock the wheels before jacking the vehicle. Applying only the parking brake is insufficient to prevent the vehicle from moving; when a rear wheel is jacked up, the vehicle blocked only by the parking brake could move, creating a very dangerous situation.
- Ensure that there are no people or objects present in the vehicle before it is jacked up.
- In order to ensure safety, doors should never be opened and the engine should never be started during a jack-up operation. In addition, you should never have any part of your body below the vehicle at this time, nor allow anybody else to do so. Failure to observe this precaution could lead to an accident if the jack were to slip.
- If the underside of the vehicle is to be worked on after jacking up, jack stands must be used to support the vehicle.
- The jack must only be used at one of the specified jacking points. In addition, you must confirm that it makes good contact with the specified point.
- In order to provide extra safety should the jack slip, once a spare tire has been removed, it should be placed under the vehicle near the jack.
- Before starting a jacking operation, ensure that the jack and the jacking point to be used are clear of dirt, oil and grease. Failure to observe this precaution could lead to an accident should the dirt or oil cause the jack to slip.
- If your vehicle is equipped with a differential lock system or limited slip differential (LSD), it might start moving when the engine power is transmitted to the rear axle even when one of the wheels on the axle is raised clear of the ground. Do not start the engine with any rear wheel in contact with the ground.
- The jack provided with your vehicle must be used only for changing tires and fitting or removing tire chains. In order to ensure safety, furthermore, only one wheel should be jacked up at a time.
- If using a two-stage, extension type jack and the stop mark (yellow) becomes visible, stop raising the vehicle. Failure to observe this precaution can result in jack breakage.
- Do not use more than one jack at any one time.
- The jack supplied with your vehicle is specifically for that vehicle. Do not use it on another vehicle and never use another vehicle's jack.
- Turn the bleeder screw slowly. Turning it quickly will cause the vehicle to drop and the jack may slip off.

---

## Jacking Points

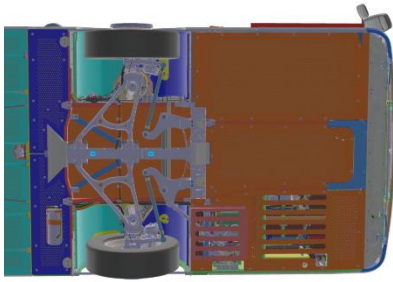

Apply the jack to the jacking point of the bracket.

### WARNING

- Do not jack up or lift up except at specified locations.
- Do not work on or leave the vehicle supported only by a jack.

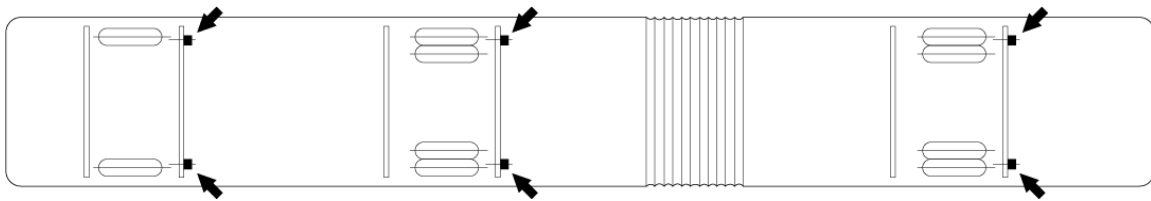

---

## WINDSHIELD WASHER FLUID

Check the level of fluid in the windshield washer tank. In addition, spray windshield washer fluid and operate the windshield wipers to check for any areas not properly wiped. At this time, also check the windshield washer's spraying condition.

---

### Refilling Windshield Washer Fluid

1. The windshield washer fluid tank is located under the instrument panel on the passenger side.
2. Open the cap and fill the tank with windshield washer fluid to the opening.

### ADVICE

- Upon factory shipment, new vehicles contain only tap water in the washer fluid tank. Adjust the concentration of the fluid to suit your own usage.
- Follow the instructions provided with the windshield washer fluid regarding the ratio for mixing with tap water.
- Poor quality products, engine coolant, and soapy water must not be used. Failure to observe this precaution can result in nozzle blockage or damage to painted surfaces.
- The washer should never be used while the tank is empty. Operating the washer with the tank empty can result in motor damage.

## WINDSHIELD WIPER BLADES

### Windshield Wiper Blade Replacement

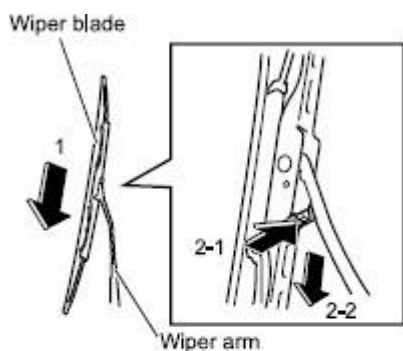

1. Pull the wiper arm up to the vertical position.
2. While pressing the wiper-blade hook towards the arm, slide the blade downwards (towards the base of the arm).

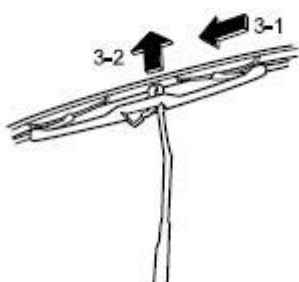

3. With the blade and arm almost perpendicular, remove the blade from the arm.



4. Insert the blade while holding it almost perpendicular to the arm.

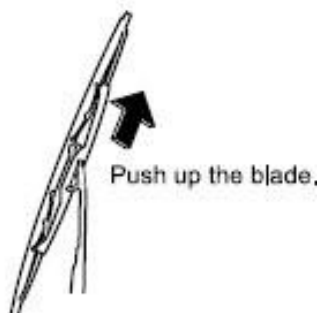

5. Then, with the blade and arm oriented in the same direction, push up the blade until it locks into place on the arm.

---

## Replacement of Wiper Rubber Insert

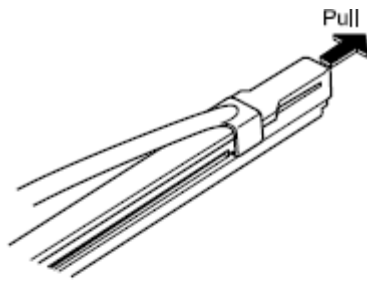

1. Remove the wiper blade from the wiper arm.
2. Pull the wiper rubber insert in the direction indicated by the arrow and extract it from the wiper blade.

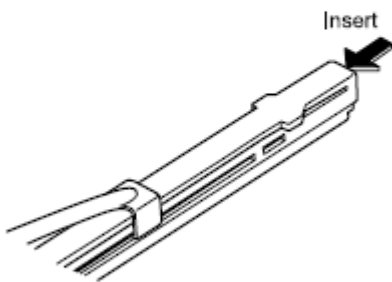

3. Insert a new wiper rubber insert into the wiper blade.

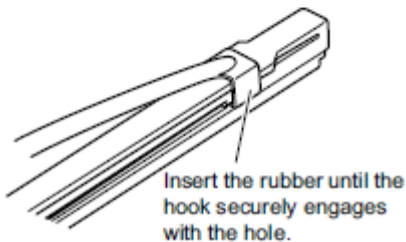

4. Continue pushing in the wiper rubber insert until the wiper blade's hook engages with the hole in it, and then confirm that the rubber insert is securely held in place.
5. Attach the wiper blade to the wiper arm.

---

## HEADLIGHTS AND TURN SIGNAL LIGHTS

Turn the starter switch to the "ON" position, and then check the way in which the headlights, turn signal lights, and other exterior lights come on and flash.

In addition, depress the brake pedal to confirm whether the stop lights come on, and shift the transmission to "R" position to confirm whether the backup lights come on.

Also examine the lights for discoloration, damage, and looseness.

## HANDLING THE BATTERY

### DANGER

- Usage or charging of the battery when the battery fluid is below the "LOWER LEVEL" line can accelerate deterioration and give rise to dangerous situations such as the generation of heat and even explosion.
- If battery fluid should come in contact with an eye, immediately wash away using a large amount of water and continue washing for at least 5 minutes. Following this, you should seek medical assistance.
- When using tools or other metal objects in the vicinity of the battery, take care to prevent them from coming into contact with the positive terminal. As the vehicle itself will conduct electricity, any such contact can result in a short-circuit and a highly dangerous electric shock.
- A vehicle battery generates extremely flammable hydrogen gas. For this reason, operations producing sparks or requiring the usage of an open flame must never be carried out near a vehicle battery. Failure to observe this precaution can result in explosion if the hydrogen gas ignites. Whenever wiping up battery fluid, a damp cloth should be used.

### WARNING

- Always stop the engine whenever the battery is to be inspected.
- Dilute sulfuric acid is used as the battery fluid. Special care must be taken to ensure that this fluid does not come into contact with skin, clothing, or metal surfaces.
- When disconnecting cables, turn the starter switch to the "LOCK" position, wait at least 3 minutes (models with SCR) or 2 minutes (models without SCR), and then disconnect the cables starting with the negative cable from the terminals. If the negative cable is disconnected within 3 minutes (models with SCR) or 2 minutes (models without SCR), the engine control module may malfunction. When reconnecting them, the negative cable should be reconnected last.

---

## REFRIGERANT

The air conditioning system will not be able to cool the cab interior effectively if the refrigerant level is low. Accordingly, the refrigerant level must be topped up whenever necessary.

Please contact your Isuzu Dealer whenever refrigerant must be added.

### ADVICE

- Operating the air conditioning while the refrigerant level is too low leads not only to poor cooling performance but also to air conditioning system damage.

## INTERIOR AND EXTERIOR MAINTENANCE

### EXTERIOR MAINTENANCE

#### Washing

If the vehicle is operated with foreign material adhering to the exterior, this material may react chemically with paint or plating, resulting in staining, discoloration, rusting or corrosion of components. Also, the material may become trapped within mechanical components, adversely affecting their functions or forming an aerodynamic resistance. In the following cases, therefore, the vehicle must be washed and all foreign matter removed.

- When soot, iron powder, dead bugs, bird droppings, tree sap or oily matter from coal tar and smoke has adhered to painted surfaces.
- When the vehicle has been driven in coastal areas.
- When the vehicle has been driven on roads where road chemicals have been applied.
- When a large amount of mud or dirt has adhered to the exterior.
  1. Fully turn on the tap, and wash out the undercarriage and suspension.
  2. Close all openings and wash the cab and cargo body panels using a neutral detergent.
  3. Clean wheels and tires using a brush and detergent.
  4. After washing away all remaining detergent, use a shammy or other clean cloth to fully remove all moisture and water droplets.

#### CAUTION

- Do not apply water directly in order to clean the cab interior. Failure to observe this precaution can result in malfunction or breakdown of electronic control units and electrical components, or in rusting of the cab floor.
- Do not apply water from a high-pressure washer nozzle directly to the electric connectors. Failure to observe this precaution can lead to faulty operation of the electrical system.

## ADVICE

- If an automatic car or truck-wash is used with vehicles having dark or metallic coating, the painted surfaces can be damaged by the brushes, lose their luster or be very noticeably scratched.
- Do not direct a large amount of water at the air inlet openings.
- Do not apply water to the engine compartment or at electrical components. Failure to observe this precaution can lead to a poorly starting and operating engine and problems in the electrical system.
- Ensure that mirrors and the antenna are retracted before washing the vehicle.
- If an automatic car or truck-wash must be used, avoid a high-temperature, high pressure type machine. Failure to observe this precaution can lead to heat deformation and breakage of plastic components, or to water leaks into the cab.
- When using an automatic car or truck-wash, ensure that a distance of at least 0.4 m is maintained between the nozzle and the vehicle, and when washing door windows, that the spray is perpendicular to the surface of the glass.
- Ensure that all detergent is fully washed and wiped away. Particularly in the case of strong alkaline detergents (typically those for industrial uses), there is a danger that hairline cracks can develop in lighting-cluster lenses if the vehicle is operated without detergent being fully wiped away. Always read the detergent manufacturer's instructions carefully before use.
- Airborne dirt that adheres to plastic front bumpers as a result of rain, for example, can be difficult to remove.

In such a case, use a commercially-available cleaner to clean away the dirt, and then apply a wax for use with plastic components.

---

## Vehicle Storage

In order to maintain your vehicle's attractive appearance as long as possible, special consideration must be given to its storage location.

If the vehicle is stored or kept for an extended period of time in any of the following locations, a chemical change may occur in the paintwork, resulting in staining, discoloration, rusting, and corrosion of components.

- Locations where a large amount of oily matter, soot, heavy smoke or metal powder can adhere to the vehicle.
- Areas around pharmaceutical plants and other facilities that discharge chemical matter.
- Coastal areas
- Locations where a large amount of dead bugs, bird droppings or tree sap can adhere to the vehicle.

---

## Waxing

Painted and chrome-plated surfaces should be waxed once or twice a month, or whenever water is being poorly repelled on the surfaces. Ensure that wax is not applied in direct sunlight, and that the temperature of the painted surface is no more than 40°C.

Always follow the instructions provided with your wax product.

### CAUTION

- Wax must not be applied to the windshield. Failure to observe this precaution can result in irregular reflection of light, impairing your view.

### ADVICE

- Do not use wax containing abrasive material. Failure to observe this precaution can lead to scratching of painted surfaces or plastic components.
- The application of wax to rubber component surfaces can result in permanent whitening.

### NOTE

- Wax must not be applied to the windshield. A layer of wax can impair your view in rainy weather and can also lead to rough movements of the windshield wiper.
- If engine oil or grease comes into contact with the windshield, staining or discoloration may result. It must be immediately cleaned away.

---

## Windshield Care



If not fully cleaned by the windshield wipers, the windshield should be cleaned using Isuzu genuine glass cleaner.

## INTERIOR MAINTENANCE

Remove dust and dirt from the interior of the cab using an automotive cleaner or vacuum cleaner, and gently wipe surfaces clean using a cloth wet with warm or cold water.

### WARNING

- Petroleum ether, gasoline and other organic solvents should not be used to clean seat belts. In addition, seat belt webbing should be neither bleached nor redyed. Failure to observe these precautions can lead to the performance or strength of the seat belts being impaired. In the case of a collision, therefore, the belts could be insufficiently effective, and serious life-threatening injuries could result. When cleaning, use warm water in which a small amount of neutral detergent has been dissolved to gently wipe the seat belts.

### CAUTION

- The interior of the vehicle must never be cleaned using acidic or alkaline solvents, or petroleum ether, gasoline, and other organic solvents. Failure to observe this precaution can result in discoloration and staining. It should be noted that certain types of cleaning products contain these compounds. Be sure to read cleaning product labels carefully.
- Air fresheners (liquid, solid, gel or plate types) must not come into direct contact with, or spill onto, interior components such as the air conditioning or audio system. Compounds contained in these products can cause discoloration, staining or peeling of paint.
- Glass cleaners that contain these compounds must not be used to clean the inside of the windshield or window glass. To clean the glass, wipe using a cloth wet with warm or cold water.

---

### Seat Belt Care

A dirty seat belt can develop retracting problems, and for this reason, regular inspection and upkeep are required.

### CAUTION

- Seat belt webbing can lose its strength when bleached or redyed, or when cleaned using gasoline, paint thinners or other volatile substances.
- Do not disassemble the seat belt mechanism in order to remove any foreign material or objects that may have entered the buckle. Instead, arrange for inspection and maintenance to be carried out by your Isuzu Dealer.

---

### Fabric Seat Covering and Carpet Care

Remove dirt and dust using a home-use electric vacuum cleaner.

Do not remove the carpet. Use standard household cleaning products and methods to remove stains from food, drink and the like.

Be sure to use neutral detergents or cleaning products indicated as higher alcohol based detergents.

## MAINTENANCE DATA

For safe and economy driving, we recommend that you have your vehicle inspected and serviced regularly according to the schedule indicated in this chapter.

### DAILY MAINTENANCE

- Check the tires
- Check the brakes
- Check the engine coolant level
- Check the engine oil level
- Check the transmission oil level
- Drain the condensed water from the air tanks especially in winter months
- Check the diesel exhaust emission fluid level
- Check whether the external lights work appropriate to the safe driving
- Check the belts
- Check the air levels
- Check bus accident and original parts situation.

### WEEKLY MAINTENANCE

- Check the wheel pressures
- Check the level of the steering wheel hydraulic tank
- Check the level of window washing water
- Visually inspect chassis and body parts for corrosion

### CAUTION

- Should not use water jet cleaning machine inside of the bus
- Should not use corrosive material on the bus surface
- Should not use wash the vehicle with hand wash brush
- Informing the authorized service in case of accident
- Regular maintenance in authorized service

### MAINTENANCE SCHEDULE

---

To drive your vehicle safely and at minimum cost, it is essential to have your vehicle regularly inspected and serviced at your Isuzu Dealer as per the specified maintenance schedule.

Letters Used to Indicate Maintenance Service Types:

I: Visual Inspect then clean, adjust, repair, or replace as

necessary  
A: Adjust

R: Replace

T: Tighten to the specified torque

L: Lubricate

### ADVICE

- When inspecting the items listed below, also inspect the routine inspection items as well.

Service Interval (x1000 km)	15	30	45	60	75	90	105	120	135	150	165	180	195
Diagnostic control of engine failures	I	I	I	I	I	I	I	I	I	I	I	I	I
Engine oil	<b>R (90.000 km / 1500 h / 6 months)</b>												
Engine oil refill (Optional)	<b>R (90.000 km / 1500 h / 6 months)</b>												
Valve gap setting	<b>A (240.000 km / 5000 h / 48 months)</b>												
Oil filter	<b>R (90.000 km / 1500 h / 6 months)</b>												
Fuel filter	<b>R (90.000 km / 1500 h / 6 months)</b>												
Fuel water separator filter (reference interval for optimum fuel quality)	I	I	I	R	I	I	I	R	I	I	I	R	I
Fuel water separator filter: water level	<b>Check water level every 15.000km</b>												
Air filter element (reference interval for optimum fuel quality)	I	I	I	R	I	I	I	R	I	I	I	R	I
Air Filter restriction	<b>I: 15.000 km / 250 h / 3 months</b>												
Fuel pipes and hoses	I	I	I	I	I	I	I	I	I	I	I	I	I
Draining of condensation tank	I	I	I	I	I	I	I	I	I	I	I	I	I
Cooling system leakage control	I	I	I	I	I	I	I	I	I	I	I	I	I
Hydrostatic fan driving oil and filter	<b>R (60.000 km / 2000 h / 24 months)</b>												
Hydrostatic fan drive oil level, leakage and function control	I	I	I	I	I	I	I	I	I	I	I	I	I
Radiator Pressure Cap		I		I		I		I		I		I	
Coolant Filter	<b>R (30.000 km / 500 h / 6 months)</b>												
Crankcase Breather Filter	<b>R (90.000 km)</b>												
Urea tank filter						R						R	
DEF system leak control	I	I	I	I	I	I	I	I	I	I	I	I	I
Urea dosing unit filter	<b>R (330.000 km / 6500 h)</b>												
Crankcase Ventilation Filter	<b>R (90.000 km)</b>												
Exhaust treatment particulate filter cleaning	<b>I: Every 30,000 km - Cleaning every 90,000 km - R:450,000 km</b>												
External cleaning of honeycomb radiators		I		I		I		I		I		I	
Belt tension and damage*			I			I			I			I	
Pulley and belt alignments	<b>Every 60.000km - Damage check</b>												
Grease lubrication	I	I	I	I	L	I	I	I	I	L	I	I	I
Auto greasing oil fill (Optional)					L					L			
Transmission oil and filter	<b>R (180.000 km / 36 months)</b>												
Transmission ventilation valve cleaning		I		I		I		I		I		I	
Transmission oil leakage control	I	I	I	I	I	I	I	I	I	I	I	I	I
Transmission connecting bolts torque control		I		I		I		I		I		I	
Front axle pins and bushings	I	I	I	I	I	I	I	I	I	I	I	I	I
Differential oil	<b>R (180.000 km / every 36 months) (Hot Country: 120.000 km or every 24 months)</b>												
Rear axle and brake calipers connection bolts visual check	I	I	I	I	I	I	I	I	I	I	I	I	I
Rear axle breather tube	I	I	I	I	I	I	I	I	I	I	I	I	I
Hydraulic steering oil	<b>R (120.000 km / every 24 months)</b>												
Hyd. Str. Sys. leakage	I	I	I	I	I	I	I	I	I	I	I	I	I
Hyd. Str. Sys. Connections visual check	I	I	I	I	I	I	I	I	I	I	I	I	I
Hydraulic steering hose visual check	I	I	I	I	I	I	I	I	I	I	I	I	I
Tire bolts	I	I	I	I	I	I	I	I	I	I	I	I	I
Wheel air pressure	I	I	I	I	I	I	I	I	I	I	I	I	I
Wheel hub bearing	I	I	I	I	I	I	I	I	I	I	I	I	I

Service Interval (x1000 km)	15	30	45	60	75	90	105	120	135	150	165	180	195
Brake pipes and hoses leakage	I	I	I	I	I	I	I	I	I	I	I	I	I
Brake pads and disc control	I	I	I	I	I	I	I	I	I	I	I	I	I
Caliper adjusting bolt	<b>Check when you change caliper pad</b>												
Measuring caliper gap													
Caliper piston blowers													
Measuring caliper control movement													
Looseness in shock absorbers and connectors	I	I	I	I	I	I	I	I	I	I	I	I	I
ECAS settings	<b>Every 60.000 km</b>												
Air bellows	I	I	I	I	I	I	I	I	I	I	I	I	I
Function control of headlights, signals, parking lights, fog lights and brake lights	I	I	I	I	I	I	I	I	I	I	I	I	I
Internal illumination control	I	I	I	I	I	I	I	I	I	I	I	I	I
Function control of wipers and window washing system	I	I	I	I	I	I	I	I	I	I	I	I	I
General control of fuse panel, electric cables and sockets	<b>Every 60.000 km</b>												
Gas, brake and clutch pedal	I	I	I	I	I	I	I	I	I	I	I	I	I
Battery connection	I	I	I	I	I	I	I	I	I	I	I	I	I
Starter electric connections			I			I			I			I	
Pneumatic door adjustment	I	I	I	I	I	I	I	I	I				
Function control of the safety gear of all doors	I	I	I	I	I	I	I	I	I	I	I	I	I
Air leakage, damage, tightness and door function control of door elements	I	I	I	I	I	I	I	I	I	I	I	I	I
Compressor pressure line	I	I	I	I	I	I	I	I	I	I	I	I	I
Control of rearview connectors	I	I	I	I	I	I	I	I	I	I	I	I	I
Corrosion control of chassis and parts of body			I			I			I			I	
Replacement of additional heater fuel filter				R				R				R	
Air condition compressor oil	<b>I: every 5000 hours or every 36 months</b>												
Air condition gas and oil	<b>I: every 4000 hours or every 24 months</b>												
Antifreeze		R		R		R		R		R		R	
Real time clock battery	<b>R: every 24 months</b>												
Underbody wax checking and repairing	<b>I: every 15.000 km</b>												
Washing the entire bus, making sure to remove all road chemicals	<b>I: Winter period monthly</b>												
Air dryer filter	I	R	I	R	I	R	I	R	I	R	I	R	I
*W1-Check folding bellows	<b>I: at 15.000 km only once</b>												
**W2-Check folding bellows							I						
Lubrication of the folding bellows bearing							L						
***W3-Check folding bellows	<b>I: each 1.000.000 km at least every 10 years</b>												

## NOTE

- Wheel air pressure must be inspected daily.
- External cleaning of honeycomb radiators must be done every 6 months. The air condition air suction filters must be cleaned every 1 month. It must be replaced with a new filter every year.
- The air conditioner antiviral pollen filters must be replaced with a new filter every year.
- Make a visual inspection of the tube for the first 5 years, referring to the maintenance label on the fire extinguisher. At the end of 5 years, do the maintenance of the tube. In addition, the label on the fire extinguisher will be marked after each control.
- For fire extinguishing system; extinguishing fluid must be replaced every 5 years, tanks must be replaced every 10 years.
- Hot Country: The average temperature exceeds 25°C during 2 months in a year or the temperature exceeds 40°C during 7 days in a year.
- Check official ZF website for up to oil catalogue.
- Crankcase ventilation hoses must be controlled every 60000 km. Crankcase ventilation filter must be replaced every 90.000 km.
- The antifreeze must be replaced once a year.
- Wheel hub bearings must be greased, with grade 12H, every 500.000 km or 4 years.
- Air dryer filter must be replaced every year or 30000 km
- Suspension bushings (stabilizer and other) should be replaced if 15,000 km wear control is required.

\*The tension of the belt should be measured, if the tension is outside the limits, only the belt should be changed, and the tension measured again. If it is still outside, this time the belt tensioner should be replaced.

- When driver and bus back to fleet\parking – don't stop engine and give to him to work a few minutes until Consep will drop water from self body.

\*For W1 the following will be checked.

- Articulation
- Folding bellows
- Center hoop stabilization
- Energy guidance in roof section
- Energy guidance in lateral area
- Checking and aligning suspension wheels

\*\*For W2 the following will be checked.

- Cleaning the articulation system
- Articulation system
- Emergency damping check (only for articulation systems with ACU control unit)
- Lubrication
- Center hoop stabilization
- Energy guidance in roof section
- Energy guidance in lateral area
- Checking hose assemblies (articulation area)
- Checking and aligning suspension wheels

\*\*\*For W3 the following will be checked.

- Complete maintenance W2
- Check all fastening bolts
- Visual inspection of the load bearing structure (casting)

## IN CASE OF EMERGENCY

### TROUBLESHOOTING

Performing regular inspections and maintenance prevents damage. Be sure to perform inspections and maintenance at regular intervals. Also, quickly rectify any fault in the vehicle (even a small fault) to prevent it from becoming more serious.

If a symptom shown in the following table occurs, perform inspections and take corrective action in accordance with the table. If you are unable to perform a repair, the corrective action shown in the table does not eliminate a symptom or you cannot locate a fault, contact the nearest Isuzu Dealer.

### WHEN THE VEHICLE BREAKS DOWN DURING DRIVING

1. Operate the hazard warning flasher and pull the vehicle immediately over to a safe place that does not impede traffic (shoulder, verge). Place the triangle reflectors to alert other traffic to the presence of your vehicle.
2. Have the other passengers get out and wait in a safe place.
3. Walk to a safe place and take appropriate measures by using the closest telephone, etc.

#### WARNING

- Leaking fuel from the vehicle is dangerous due to possible combustion or explosion. Stop the engine immediately.

### WHEN THE TIRE GOES FLAT

When the tire gets flat while driving, avoid hard braking, hold on to the steering wheel firmly and stop the vehicle.

The tire should be changed on a flat space to prevent obstructing other vehicles or pedestrians.

#### WARNING

- If you continue to drive on a flat tire, undue force will be applied to the wheel bolts, possibly causing the bolts to break and the wheel to come off.

### WHEN THE ENGINE STOPS WHILE DRIVING



For full-air brake models, the brake air pressure will not rise, so immediately stop the vehicle at a safe place. Do not panic.

Press the brake pedal to reduce speed, head immediately for a safe place, stop the vehicle and perform an inspection. If the engine cannot be started, promptly have the vehicle inspected and repaired by the nearest Isuzu Dealer.

If the engine stopped because the vehicle ran out of fuel while driving, refueling alone will not be enough to restart the engine. Bleed the fuel system after refueling the vehicle.

**WHEN THE ENGINE STALLS AND CANNOT BE RESTARTED**

Place the gearshift lever in the "N" position, and if the shift indicator shows "N", push the vehicle to a safe place. If the shift indicator displays a shift position other than "N", place the emergency switch to "ON" and the gearshift lever into the "N" position. Then, make sure that the shift indicator displays "N" and push the vehicle to a safe place.

**NOTE**

- For vehicles with hill start aid (HSA), cancel the HSA by pressing the HSA OFF switch.
- For vehicles with Hill Hold Assist, cancel the Hill Hold Assist by pressing the Hill Hold Assist OFF switch.
- In A/T model vehicles, after removing the shaft, the vehicle must be pushed and pulled to a safe area.

**WHEN THE BRAKES DO NOT WORK**

If the brakes become ineffective unexpectedly, reduce speed by quickly shifting down. Gradually pull the parking brake lever while firmly holding on to the steering wheel. Stop the vehicle on the side of the road.

**CAUTION**

- It is very dangerous to suddenly pull the parking brake lever all the way while moving at high speed. Reduce speed first by shifting down and then gradually pull the parking brake lever.

**NOTE**

- In worst case conditions on a mountain road or similar situations, stop the vehicle by scraping along a guardrail or cliff, or drop the front and rear wheels of one side into a ditch at the side of the road.

**WHEN THE BATTERY GOES FLAT**

Use a jumper cable (sold separately) and the batteries of another vehicle to start the engine in this sequence.

1. Check the battery fluid level in the disabled vehicle.
2. Use a vehicle that has a charged battery with the same voltage.
3. Remove the battery cover and connect the jumper cables in the numbered sequence in the drawing.
4. After connecting the cables, start the engine of the vehicle with the booster battery.
5. Slightly rev up the engine of the vehicle with the booster battery and start the engine of the disabled vehicle.
6. If the engine in the disabled vehicle starts, remove the jumper cables in the reverse sequence as they were connected.

## CAUTION

- For safety and the protection of the vehicle, do not push-start the vehicle.
- Make sure that the booster batteries in the vehicle providing the charge have the same voltage as the disabled vehicle.
- Under no circumstances should the battery's positive and negative terminals be put in contact with one another.
- When connecting the cables, under no circumstances should the clips be allowed to touch each other.
- Ask the nearest Isuzu Dealer to recharge the battery.
- Do not disconnect a battery terminal with the engine running. It could cause a breakdown in the electrical system.

## WHEN THE FUEL RUNS OUT



When the fuel runs out, air will enter the fuel system, so refueling alone will not be enough to restart the engine. Ask the nearest Isuzu Dealer to bleed the fuel system.

### WARNING

- Wipe off any fuel that adheres to the vehicle body or the engine compartment below the cab. This could cause a fire.
- To remove air from the fuel, it is bled using the pump on the fuel filter. After refueling, the pumping process starts before the engine is started and continues until the pump hardens. In the meantime, engine start attempts are made and pumping continues until the engine starts.

## WHEN THE WARNING LIGHT COMES ON

### BRAKE SYSTEM WARNING LIGHT



The brake system warning light comes on while the engine is running (after startup) in the following situations:

- Drop in the level of brake fluid (due to brake lining wear or fluid leakage, etc.)
- Abnormality in the charging system (such as a generator malfunction, etc.)
- On an anti-lock brake system (ABS) model, abnormality in the ABS.

## CAUTION

- If this warning light comes on while the engine is running, immediately stop the vehicle in a safe place well clear of traffic and promptly contact the nearest Isuzu Dealer for inspection.

---

## AIR PRESSURE WARNING LIGHT



When this warning light comes on, there is insufficient air pressure in the air tank and the brakes will not work properly. A warning buzzer will sound at this time.

Immediately stop the vehicle in a safe place, perform checks and take corrective action. The warning buzzer will stop when the parking brake lever is pulled.

---

### Check and Corrective Action

- Run the engine at idle and raise the air pressure until the warning light goes out.
- When the warning light does not go out or when it takes longer than the specified time for the light to go out after an air pressure of 0 kPa (0 kgf/cm<sup>2</sup>/0 psi) is reached, repair is required.  
Contact the nearest Isuzu Dealer.

### WARNING

- Do not drive the vehicle when the warning light is on. Brakes are not fully functional, so the vehicle is in a dangerous condition to operate.

---

## GENERATOR WARNING LIGHT

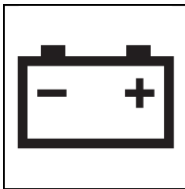

When this warning light comes on, the charging system may have failed.

Immediately stop the vehicle in a safe place, perform checks and take corrective action.

---

### Check and Corrective Action

1. Check to see if the fan belt is broken or loose.
2. If the fan belt is loose, adjust the tension.
3. If there is no abnormality in the fan belt, contact the nearest Isuzu Dealer.

### CAUTION

- Do not drive the vehicle when the warning light is on. The battery can be discharged.

### NOTE

- Since disassembling is required to replace the fan belt, have it performed by the nearest Isuzu Dealer.

---

## ENGINE OIL PRESSURE WARNING LIGHT

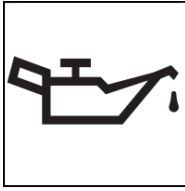

When this warning light comes on, the oil pressure is too low.

Immediately stop the vehicle in a safe place, stop the engine, perform checks and then take corrective action.

---

### Check and Corrective Action

1. Check the engine oil level.
2. If the engine oil level is too low, check for leaks and add oil.
3. When the oil level is normal and there are no oil leaks, the oil filter may be clogged.  
Replace the oil filter.
4. When the oil level is normal and the oil filter is not clogged, but there are oil leaks, contact the nearest Isuzu Dealer.

### CAUTION

- Do not drive the vehicle when the warning light is on. It could damage the engine.

### NOTE

- In winter, when the engine oil temperature is low and the oil viscosity is high, the light might come on for a time. It will go out when the engine warms up.

---

## CHECK ENGINE WARNING LIGHT

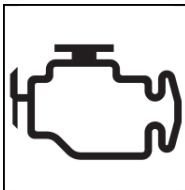

If this warning light comes on while the engine is running, there may be a problem with the engine electronic control system. Since checking and repairing the control system is required, immediately contact the nearest Isuzu Dealer.



## WHEN THE ENGINE OVERHEATS



If engine power drops and the needle on the engine coolant temperature gauge goes up above the upper limit of the safety zone and enters the "H" zone, the engine is overheating. The engine overheats warning light will come on and the warning buzzer will sound. Either steam or boiling water will squirt out of the radiator. Take the following corrective actions immediately.

1. Operate the hazard warning flasher and pull the vehicle immediately over to a safe place that does not impede traffic (shoulder, verge) and park it.
2. Lower the temperature of the engine for a while with the engine idling. While running at idle, the heating system is activated at the same time and it is tried to be lowered. Make sure that the hydraulic fan turns.
3. When the needle of the engine coolant temperature gauge returns to the middle of the safety zone, stop the engine.
4. Check the engine coolant level in the reserve tank and radiator after the engine has sufficiently cooled. If the level is insufficient, add engine coolant. Also, check to see if the fan belt is loose or has been damaged.
5. Inspect to see if there is any dirt, etc. attached to the front surface of the radiator and intercooler. Also, inspect to see if there is anything blocking the core. If there is anything attached, clean and remove it.

## WHEN THE BULB DOES NOT COME ON

1. Check each bulb for blowout.
2. If a bulb has blown out, replace it. Always place the starter switch in the "LOCK" position and place all the other switches in the off position before replacing the blown bulbs.
3. If the bulb has not blown out, the fault may be in the wiring. Contact the nearest Isuzu Dealer.

### CAUTION

- Using bulbs with a wattage other than that specified could cause the bulb or the wiring to become hot. This could result in the warping of the lens and case, and it could also lead to the outbreak of fire.
- Bulbs are hot immediately after they go out. When replacing the bulbs, avoid being burned by making sure they are fully cooled.
- Never drive the vehicle with the bulbs not working. This could result in an accident.

## WHEN YOUR VEHICLE IS INVOLVED IN AN ACCIDENT

Stay calm and take the following steps:

1. Avoid a chain of accidents  
Operate the hazard warning flasher, pull the vehicle immediately over to a safe place that does not impede traffic (shoulder, verge) and stop the engine.
2. Aid the injured  
Render whatever first aid is possible to injured people until a doctor or ambulance arrives. In particular, do not move people with head injuries. If there is a danger of a series of accidents, move them to a safe place.
3. Contact the police  
Contact the police, give them the information on the location of the accident, the conditions, injured people and the extent of their injuries, and then receive instructions.
4. Confirm information from other parties (name, address and telephone number) and the conditions of the accident.
5. If necessary, contact the insurance company or the dealer you purchased the vehicle from.

### ADVICE

- Make sure to notify the police and consult a doctor even for small accidents and light injuries. When receiving a blow to the head in particular, it is possible for symptoms to develop later even if there are no external wounds.

## WHEN DRIVING ON BAD ROADS

Pressing the accelerator pedal will dig the vehicle deeper into the mud and make it harder to extricate. Either put stones, tree branches or blankets under the tires to gain traction, or repeatedly drive forward and in reverse and use the vehicle's momentum to extricate it.

## WHEN TOWING

To move a disabled vehicle, it is best to rely on someone in the wrecker or tow truck business. If that is not possible, follow these procedures.

When towing, use appropriate equipment and comply with local legal requirements. Do not try to start the engine by towing or pushing the vehicle.

### WARNING

- Be sure to chock the wheels when disconnecting the propeller shaft. The vehicle could start to move and cause a serious accident.
- In A/T model vehicles, after removing the shaft, the vehicle must be pushed and pulled to a safe area.

When it is possible to operate the steering wheel, the vehicle can be towed with all wheels on the ground. However, the power steering will not be able to provide any power assist when the engine cannot be started.

If the engine of a full-air brake vehicle cannot be started, the air pressure will be low and the brakes will not work. If the engine cannot be started, use a tow truck to move the disabled vehicle. If the transmission is damaged, disconnect the propeller shaft at the rear axle flange and secure it to the frame.

If the rear axle fails or rear axle failure is suspected, remove the axle shaft and plug up the opening of the hub to prevent differential gear oil from leaking, or to prevent dirt or foreign objects from entering the axle.

**MAIN DATA**

**MAIN DATA AND SPECIFICATIONS**

<b>Dimension (mm)</b>	
Max. Length	18200
Max. Width	2550
Max. Height	3161
Wheelbase 1	5850
Wheelbase 2	6170
Front Overhang	2700
Rear Overhang	3480
Front Track Width	2152
Middle Track Width	1888
Rear Track Width	1872
<b>Mass (kg)</b>	
Gross Vehicle Mass	28000
Curb Weight	26536
Front Axle Capacity	6929
Middle Axle Capacity	6881
Rear Axle Capacity	12726
<b>Engine</b>	
Model	Cummins L9E6E370B
Type	Diesel EGR Turbocharged
Number of Cylinders	6
Engine Volume (cm <sup>3</sup> )	8900
Max. Power (kW/rpm)	276 kW/2100 rpm
Max. Torque (Nm/rpm)	1600 Nm/1400 rpm
Exhaust Emission Class	Euro VI E
<b>Gearbox</b>	
Model	ZF ECOLIFE 6AP1700B
Number of Gears, Type	6+1
Final Gear Ratio	6,19
Steering System	Hydraulic
<b>Bellow System</b>	
	Hubner HNGK 19.5
<b>Tyres</b>	275/70 R22,5
<b>Gradeability (at GVM)</b>	33%
<b>Suspension</b>	
Front	2 air bellows, 2 hydraulic shock absorbers
Middle	4 air bellows, 4 hydraulic shock absorbers
Rear	4 air bellows, 4 hydraulic shock absorbers
Kneeling System	ECAS
<b>Brake System</b>	
Front / Middle / Rear	Disc / Disc / Disc
Brief Explanation	Full Air Brake System with ABS (EBS) and ASR (EBS), Dual Circuit,
Parking Brake	Air Actuated, Operating on Middle and Rear Axle
Auxiliary Brake	Intarder
<b>Fuel Tank (Lt)</b>	535
<b>Urea Tank (Lt)</b>	43 +/-2 lt
<b>Generator</b>	3 x 180 A
Nominal Voltage	24V
Battery	24V (2x12V) 240 Ah main battery 24V (2x12V) 50 Ah its battery

## FLUID SPECIFICATIONS

Description	Capacity	Norm	Class
Engine Oil	23.5 Lt	SAE15W 40	CES-20086, API CK-4 or CES-20081, ACEA E-9
Auto. Oil Filling System*	6 Lt	SAE15W 40	CES-20086, API CK-4 or CES-20081, ACEA E-9
Transmission Oil and Filter	17.5 Lt	ZF TE-ML 04D, 14A	CASTROL TRANSMAX DEX III MULTIVEHICLE
Differential Oil and Rear Axle	16,5 Lt	SAE80W 90	ZFTE-ML12-EcofluidX, 12M
Presuspension Greasing	-	DIN51825: KP2K-20 ISO-L-XBCEB2	ZFTE-ML12G
Steering Wheel Hydraulic Oil	8 Lt	ISO VG 46 OR VG 68	RDE 90245 – BOSCH REXROTH FLUID RATING LIST
Hydrostatic Fan Oil	9,5 Lt	ISO VG 46 OR VG 68	RDE 90245 – BOSCH REXROTH FLUID RATING LIST
Folding bellows oil	200 gr	Gleitmo 585 K	FUCHS LUBRITECH
Air Condition Compressor Oil	1,5 Lt	Viscosity ISO 46	ZXL 100PG POE oil
Antifreeze and Water 50/50	55±5 Lt	CES 14603	Petrol Ofisi EXTENDED LIFE COMPLEAT
Air Condition Gas	12 kg	R134a	Linde
Air Condition Compressor Oil (FKX50-775K)	2.5 Lt	Solest 68	2030762
Air Condition Compressor Oil (QPS55)	TBD	Solest 120	2030515
Air Condition Compressor Oil (Compressor of SR10)	0.290 Lt	PVE (FVC68D)	2030548

\* If your vehicle has Complement of Engine Oil

## PRESSURE VALUES

Name	Description	Pressure
Four Way Protector Valve	Static Closing Pressure	≥ 5,5 Bars
Air Dryer	Minimum Opening Pressure	8,1 Bars
Air Dryer	Maximum Closing Pressure	10,45 Bars
Wheels	Cold Mixed Inflation Pressure	9 Bars / 131 Psi

**SERVICE NETWORK**

COUNTRY	STORE NAME	STORE ADDRESS	CONTACT NUMBER
ALGERIA	Spa Elsecom	Rue Baha H'med, BP 200 Bab Ezzouar - Alger	+213 (0)23 85 30 86
AZERBAIJAN	AZ Auto LLC	2207 Nobel avenue AZ1006 - Bakü	+(994) 124964598
BOSNIA	Sejari d.o.o. Sarajevo	Blažuj 78, 71215 Blažuj - Sarajevo	+387 33 770 306
BULGARIA	Isubus Ltd.	Botevgradsko Shose Blvd. 1839 Sofia	+(359) 28182929
CROATIA	Presečki grupa d.o.o.	Frana Galoviča 15 49 000Krapina	+385 (0)49 328 000
CZECH REPUBLIC	Turancar CZ. s.r.o.	Bavorská 856/14 155 00 Praha 5	+420 776 111 113
FRANCE	Fast Concept Car	Z.I La Ribotiere 85170 Le Poire Sur Vie	+33 25 13 41 034
GERMANY	Omnicar Fahrzeughandel GmbH	Weinbrennerstrasse 10 77815 BÜHL	+49 (0)7223 8061930
GREECE	Petros Petropoulos S.A.	96-104 Iera Odos 122 10 Athens	+(30) 210349 92 00
HUNGARY	Anadolu Rom Hungary	1135 Budapest Robert Karoly Ket. 96-98	+36 703730637
ISRAEL	Universal Trucks Israel Ltd.	Industrial Area Segula, P.O. Box 4599 Petach-Tikva 49145	+972-3-9120010
ITALY	Midi Europe SRL	Via Crosaron, s.n. 37053 Cerea VR	+39 0442 328 212
LITHUANIA	UAB Saločiai Ir Partneriai	Mokyklos str. 1B, Bukiskės LT-14182 Vilniaus raj.	+370 5 2793000
MOROCCO	Maroc SDAMA	Route principale de Rabat 1, km 6,3 Ain Sebaa - Casablanca	+212 (0) 529 029 300
POLAND	Busimport PL Sp. z.o.o.	Gierlatowo 10A 62-330 Nekla Wielkopolskie	+48 61 43 86 905
ROMANIA	Anadolu Automobil Rom. Srl	Soseaua Bucuresti- Ploiesti Nr. 110 Comuna CiolPani	+4021-266 8300
SERBIA	Auto Cacak Komerc Doo	Bore Stankovica 16 11 030 Belgrade, Makiš	+381 32 376 228
SLOVAKIA	Turancar	Bratislavská 29 94901 Nitra	+421 37 6555 777