

CITIVOLT

INTRODUCTION AND USER'S GUIDE

ANADOLU ISUZU

Revision No: 06

i

GENEL / PUBLIC



Symbolic image of the Citi Volt vehicle

PREFACE

This owner's manual has been prepared to provide general information about the efficient and most economical use of your Citi Volt vehicle. We strongly recommend that you read the information provided carefully and follow all warnings. We would like you to know that our company will not be responsible for material and moral problems and damages that may occur in case of non-compliance with the specified.

When you need more detailed information about your vehicle, you can contact the authorized dealer and authorized service.

Keep the user manual in the vehicle at all times.

Due to our continuous effort to improve our vehicles, changes can be made in form, equipment and technique. The information, illustrations and specifications herein are based on the latest product information available at the time of publication of the manual and are provided by Anadolu Isuzu A.Ş. reserves the right to change without prior notice.

Thank you for choosing this product. We wish you good driving.

Anadolu Isuzu Automotive Industry and Trade Inc.

Center: Fatih Sultan Mehmet neighborhood, Balkan Street, No: 58 Buyaka E Block
Tepeüstü 34771 Ümraniye / İSTANBUL

Factory: Şekerpınar neighborhood, Otomotiv Street, No: 2 41435 Çayırova / KOCAELİ

Phone Number: 0850 200 1900

E-mail: isuzu@isuzu.com.tr

CONTENTS

SAYFA

1. INTRODUCTION	1
Chassis number	3
Identity Plate	3
Vehicle Warranty	5
Options	5
Suggestions / Warnings	6
2. GENERAL INFORMATION	9
Before Driving	10
Starting the Vehicle	12
Stopping the Vehicle	12
Opening and Closing Doors	13
Emergency exit	13
3. CONTROLS AND INDICATORS	14
Front Control Panel	15
Side Control Panel	22
Indicator and Warning Lights Panel	23
Line Board Control Panel	30
4. VEHICLE EQUIPMENT	31
Driver Seat	32
Passenger Seats	33
Digital Clock	33
Windscreen Roller Blind (Option)	34
Driver's Side Roller Blind (Option)	34
DVD Player	34
Heating and Cooling System	35
Digital Tachograph (Option)	42
Diagnostic Socket	43
Mirrors	44
Dash Camera (Option)	44
Rear View Camera System (Option)	45
Mobile DVR (Digital Recorder-Option)	45
Digital Line Board	45
Handles	46
Stop Buttons	46
Wheelchair Space	47
Disabled Passenger Ramp	47
Steering Adjustment	48
Horn	48
Pedals	48

Electrical Electronic System And High Voltage Components	49
Electrical System (Option 1-2)	50
Electrical System (Option 3-4)	51
Battery System	51
Charging Station System , Filling	54
Cluster Charge End Warning	54
Charging Time	55
Using Cable And Socket For Charging	55
Driver Rating System	55
PDU (Power Distribution Unit)	56
Quick Charge Control Unit (VCCU)	56
DC/DC converter	56
Charging Socket on Vehicle (CCS2)	57
Cooling System Radiator	57
High Voltage Heaters (Hv Heater)	58
Electric Axle	58
Engine Control Unit (MCU)	59
Batteries	61
Tire Inflator Set	61
Electronic Brake System (EBS)	62
Electronic Stability Control (ESC)	63
Electronic Brakeforce Distribution (EBD)	69
Acoustic Vehicle Alert System (AVAS)	69
Regenerative Braking	70
Engine Room Fire Detection System	70
Engine Room Fire Detection System And Control Unit	71
5. SERVICE AND MAINTENANCE	75
Cleaning the Vehicle	76
Cooling System and Antifreeze Filling	77
Heating and Air Conditioning Systems Line Filling and Air Bleeding Operations	78
Battery Cooling System Antifreeze Refill	79
Towing the Vehicle	80
Oil Change (portal stage)	85
Checking Brake Discs and Pads	87
Steering Hydraulic Tank	87
Smart Air Dryer	88
Emptying the Water Accumulated in Air Tanks	88
Electric Air Compressor	89
Glass Fountain Water Tank	89
Replacing Windshield Wipers	90
Fuse/Relays	91
Precautions for Battery Usage	91
Jack Use and Tire Change	93
Easy Serviceability	95
Corrosion & Preventive Methods	95
Vehicle Recovery Information	97
Periodic maintenance	98
6. TECHNICAL INFORMATION	103
7. AUTHORIZED SERVICES	107

1. INTRODUCTION



Symbolic image of the Citivolt vehicle

CHASSIS NUMBER



The chassis number of the vehicle is located on the profile behind the right front wheel.

IDENTIFICATION PLATE

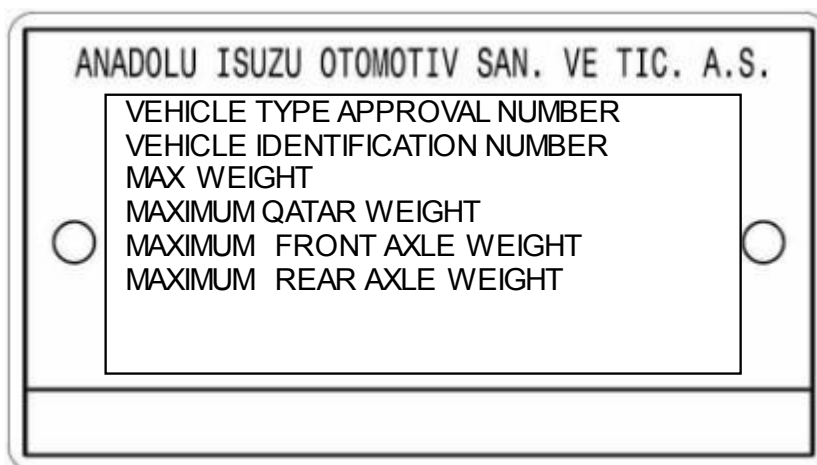

The identification plate is on the driver's seat platform at the front door entrance. It contains information on the identification plate such as VIN number, maximum axle load total, maximum front axle load and maximum rear axle load, vehicle model, engine type, drive system, wheelbase, manufacturing site

VEHICLE IDENTIFICATION NUMBER SYSTEM																
1	2	3	4	5	6	7	8	9	1	1	1	1	1	1	16	17
N	N	A	M	0	B	H	L	B	0	2	0	0	0	0	0	1
(SAMPLE)																
1-3	PRODUCER INTERNATIONAL IDENTITY CODE					NNA:	(AIOS) ANADOLU ISUZU AUTOMOTIVE INDUSTRY AND TRADE JOINT STOCK COMPANY									
4	MODEL					M:	BUS GROUP									
5	MAX LOAD WEIGHT	N:	14 PASSENGER SEAT													
		H:	17 PASSENGER SEAT													
		8	18 PASSENGER SEAT													
		F	19 PASSENGER SEAT													
		G	20 PASSENGER SEAT													
		L	21 PASSENGER SEAT													
		B	22 PASSENGER SEAT													
		C:	23 PASSENGER SEAT													
		4:	24 PASSENGER SEAT													
		E:	25 PASSENGER SEAT													
		M:	26 PASSENGER SEAT													
		D:	27 PASSENGER SEAT													
		R:	28 PASSENGER SEAT													
		P:	29 PASSENGER SEAT													
		T:	30 PASSENGER SEAT													
		K:	31 PASSENGER SEAT													
		S:	32 PASSENGER SEAT													
		U	33 PASSENGER SEAT													
		V	34 PASSENGER SEAT													
		5	35 PASSENGER SEAT													
6	36 PASSENGER SEAT															
7	37 PASSENGER SEAT															
Z:	38 PASSENGER SEAT															
9	39 PASSENGER SEAT															
A:	43 PASSENGER SEAT															
0	INDEPENDENT OF THE NUMBER OF SEATS															
6	MODEL EXTENSION	S:	STANDARD													
		A	AIR SUSPENSION													
		Z	AIR SUSPENSION (EXPORT TO EUROPE)													
		L:	SPRING													
		B:	PUBLIC TRANSPORT TYPE													
		H:	STANDARD TYPE WITH ACTUATED DOORS													
		E:	PUBLIC TRANSPORT (ALGERIAN EXPORT TYPE)													
2	INTERURBAN TYPE															
7	ENGINE MODEL	D:	CUMMINS ISB6.7E5 300B													
		E	CUMMINS ISB6.7E6 280B													
		G:	CUMMINS ISLG 6B 300													
		C:	CUMMINS ISLG 6C 300													
		F:	CUMMINS ISB6.7E6C280B													
H:	CUMMINS ISB6.7E6C300B															
8	DRIVING SYSTEM	L:	LEFT HAND DRIVE													
		R:	RIGHT HAND DRIVE													
9	WHEEL BASE	B:	5850mm													
10-11	MANUFACTURING PLANT	GB	AIOS GEBZE FACTORY													
12-17	PRODUCTION SEQUENCE NO															

VEHICLE WARRANTY

The warranty period and conditions of the vehicle are specified in the "Warranty Certificate" supplied with the vehicle. For detailed information about the warranty conditions and situations out of warranty, please refer to the "Warranty Certificate".

OPTIONS

Apart from the standard features of the vehicle, the following options can also be applied to the vehicle at any time. These features may vary.

- Windshield roller blind (Electric control or Manual control)
- Driver's side roller blind
- Driver's cabin (Closed)
- USB Charging Socket for Passengers
- Radio&MP3 player
- Microphone (Swan&swan type) & Amplifier
- Multimedia Set (Torpedo)
- DVD player
- CD player
- Monitor / LCD
- Front anti-roll bar
- Preheater
- Cruise control
- ESC/ESP
- Driver hanger
- First-aid kit
- Engine Room Fire Detection and Automatic Fire Suppression System
- Automatic Front Axle Lubrication System

SUGGESTIONS / WARNINGS

- For the spare key or in cases where the key is lost, you must report the serial number information on the ignition key to the authorized service, so make a note of the serial number information.
- Do not load your vehicle above the passenger capacity, do not change the seats. Our factory is not responsible for the problems that may arise due to the change in the load balance in the vehicle.
- Check the tire pressures frequently, always make sure they are at the correct value.
- Check the high and low beam settings, do not travel at night with defective headlights.
- Check the brake, parking and license plate lights frequently, do not set off with defective or mud-covered brake, parking and license plate lights.
- In order to ensure maximum performance in your vehicle, take care to have all maintenance done on time and regularly at authorized services.
- Liquids such as waste oil, brake fluid, antifreeze, waste filters and scrap batteries that you use in your vehicle cause great harm to the environment when they are thrown away indiscriminately. Pay attention to the fact that such hazardous wastes can be disposed of in accordance with environmental regulations.
- It is extremely dangerous to have empty cans, empty bottles or other items rolling on the floor, make sure the floor is clean and tidy, especially around the driver's seat.
- Before starting the engine, make sure that there are no flammable materials under or around the vehicle. The presence of similar materials may cause a fire.
- Before driving; Be sure to adjust the seat, steering wheel and mirrors to positions that provide the correct driving position for you.
- Make sure to wear your seat belt.
- Make sure that the windshield and side windows are clean. Keep the curtains in such a way that they do not hinder your vision and driving.
- Drive your vehicle by paying attention to traffic rules and road condition.
- If you feel any abnormality in a tire while driving, stop immediately in a safe place. If you drive with a flat tire, too much force can be applied to the wheel studs, causing the bolts to break and the wheel to come off.
- Drive at a constant speed as much as possible.
- DO NOT SWITCH OFF THE ELECTRIC MOTOR BEFORE YOU STRAIGHTEN THE STEERING WHEEL.”**

- If a warning light comes on, do not ignore it and continue driving. Note that you must take corrective action by referring to the description of meters, warning lamps and indicator lights.
- When the vehicle malfunctions while driving, turn on the hazard warning flashers and immediately pull the vehicle to a safe place where it will not interfere with traffic. Install warning triangles to alert other vehicles of your presence. Get other passengers out of the vehicle and have them wait in a safe place. Inform the nearest authorized service.
- Do not use water to wash the rear compartment, side compartment and radiator directly.
- It is strictly forbidden to use high pressure water to wash the rear electrical component room.
- Only the outer part of the vehicle body can be washed with a low pressure water gun.
- High Voltage must be disconnected before working on high voltage components.
- Before working in high voltage systems, it is necessary to wear safety equipment against all kinds of situations.
- Safe isolation from high voltage must be verified before work.
- Always pay attention to high and low voltage cables during operation.
- The work area should be isolated from normal areas.
- Always follow instructions and labels to avoid undesirable results.

Electrical works in HV systems of vehicles

- Electrical work cannot be started without taking protective measures against electric shock, short circuit and fault arcs.
- Generally, electrical systems and moving parts of equipment may not be worked on. To this end, these systems and equipment must be rendered inactive before and during operation.

Before starting work in case of any malfunction:

- Disconnect power from the system.
- Turn off the ignition.
- Remove the service/maintenance plug and/or turn off the main battery switch
- Remove the fuse.
 - Make sure the system cannot be reactivated.
- Keep the ignition key safe to prevent unauthorized access.
- Keep the service/maintenance plug secure to prevent unauthorized access and/or use a lockable cover to ensure that the main battery switch cannot be reactivated.
 - Make sure the devices are de-energized using a suitable voltage tester (note the voltage range!).
 - Ground and short-circuit the system.
 - Secure or insulate adjacent moving parts.

- These five rules are vital for safe working. The rules must be followed in the order usually specified.
- The five safety rules are general to all electrical power systems, regardless of the actual voltage level. Certain lower restrictions may apply for systems with rated voltages up to 1000 V. The first three rules must be followed when working on a high voltage system. Whether the fourth and fifth rules will also be applied should be determined on a case-by-case basis.

The following safety equipment must be used in cases where operations are to be carried out on the vehicle..

Safety equipments				
				
Protective Glasses	Protective Gloves	Protective Headphone	Protective shoes	Protective clothing

2. GENERAL INFORMATION

BEFORE DRIVING

Proper maintenance and driving are important not only in extending the service life of your vehicle, but also in the battery and electric motor.

Check Daily

For safe and comfortable driving, record the distances traveled and the condition of the vehicle while driving. Perform inspections at appropriate intervals and perform maintenance according to inspection findings. If an inspection reveals an abnormality or the vehicle has had an abnormality from previous driving, take the vehicle to the nearest Isuzu Dealer before being driven again.

Daily Control Checklist:

1. Checking components that showed abnormalities during previous driving
2. Electric axle coolant level
3. Hydraulic steering fluid level
4. Fan hydraulic fluid level
5. Brake system air pressure level
6. Brake pedal release
7. Exhaust noise from brake valve
8. Increase/decrease of air pressure level
9. Operation of meters, indicators and warning/indicator lights
10. Parking brake
11. Windshield washer fluid spray status and windshield wiper activity
12. Windshield washer fluid level
13. Steering wheel clearance and mounting condition
14. Operation of horn and turn signal lamps
15. Battery charge level
16. Lighting, flashing or damaged lights
17. Battery fluid level
18. Condensation in the air tank
19. Electric engine coolant, brake fluid, power steering fluid, fan hydraulic fluid leak
20. Air pressure
21. Cracks and other damage
22. Abnormal wear
23. Tread depth of tires
24. Disc wheel assembly status
25. Brake efficiency
26. Checking the engine at low speeds and accelerations

Keep The Floor Above The Driver's Seat Clean And Tidy



- It is extremely dangerous for empty cans, empty bottles or other items to roll on the floor, as they can get caught under the brake pedal and prevent the brake from being applied. It is also important to properly lay the mats for the pedal to work properly. Incorrectly installed mats prevent free movement of the pedals.
- Do not use the instrument panel pocket or top as a place to store items that could roll over or hinder your ride.

Choose Your Suitable Shoes for Driving

Choose shoes that allow the pedals to work properly while driving. The use of shoes suitable for riding may cause an accident.

Stop And Parking

- Choose a flat place where stopping and parking is allowed and the vehicle will not interfere with traffic. Firmly pull the handbrake and make sure the vehicle does not move.
- Remove any dirt from the vehicle's light lenses and reflectors to ensure the vehicle is visible from other vehicles.

Applying the Parking Brake

Do not apply the parking brake until the vehicle has come to a complete stop, except in an emergency. Applying the parking brake before the vehicle comes to a stop could cause the tires to lock or the vehicle to spin, resulting in an accident.

Parking Safely on a Slope

Avoid parking your vehicle on slopes as much as possible and choose a flat place. If it is unavoidable to park your vehicle on a slope, make sure that you apply the parking brake fully, that the vehicle does not move, and support the underside of the wheels with chocks for added safety. Release the steering wheel so that the vehicle is stopped by an obstacle (e.g. curb) in the event of movement.

STARTING THE VEHICLE



The marked button acts as a contact in the vehicle. When the button is pressed once without pressing the brake pedal, only the ignition is turned on, and when it is pressed again, the contact is closed.

If the button is pressed by pressing the brake pedal, the ignition and high voltage systems will be active and the vehicle will switch to Drive Ready mode, when pressed again, the ignition and system will turn off.

Please start the vehicle by pressing the brake pedal.

The main switch must be in the "ON" position. The green "Drive Ready" text on the instrument screen indicates that the vehicle is ready for action. Afterwards, the desired gear is selected and action is taken.



If the green "Drive Ready" text does not appear on the display screen, the vehicle will not start, contact the authorized service.



The vehicle must be started by pressing the brake pedal. If it is not started in this way, the compressor in the vehicle will not be activated. Please start the vehicle by pressing the brake pedal.

STOPPING THE VEHICLE



The marked button acts as a contact in the vehicle.



Do not turn off the main switch within 70 seconds when the ignition switch is on and after the ignition switch is turned off.



If the vehicle will be parked for a long time (more than 1 days), turn the main switch off.

If the vehicle will not be started for more than 30 minutes after the ignition is turned off and the instrument panel is closed for 1 minute, the switch must be turned off. If this is not done, an ECAS warning appears in the cluster.



DO NOT SWITCH OFF THE ELECTRIC MOTOR BEFORE YOU STRAIGHTEN THE STEERING WHEEL."

OPENING AND CLOSING THE DOORS

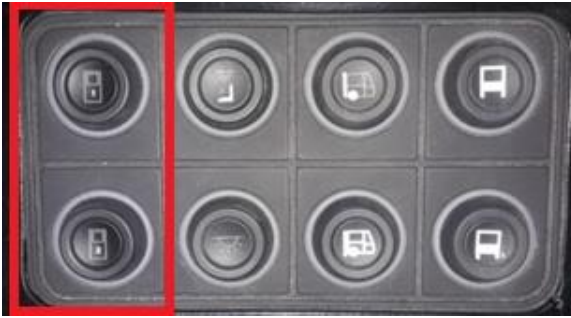

There are on/off switches on the front control panel for opening/closing the doors from the inside. The doors close automatically when the vehicle speed exceeds 5 km/h. Front door opens/closes from outside with remote control.

Opening Doors in Emergency Situations



There are air release valves on the doors for emergencies. If necessary, evacuate the air by turning the valve clockwise and open the doors by pulling inward.



There are air release valves on the sides of the doors for opening the doors from the outside when necessary. Turn the valve clockwise and push inward to open the doors.



It also has a red on/off lock on the door to open the door when the vehicle is locked from the outside with the key or there are passengers inside. When necessary, this lock is turned in the direction of the arrow, the air release valve on the door is turned to release the air and the door is opened by pulling inward.

EMERGENCY EXIT



In emergency situations, an emergency exit can be provided by breaking the windows on the right and left sides of the vehicle with the help of the emergency hammer.

3. CONTROLS AND INDICATORS

FRONT CONTROL PANEL



KEYS ON THE LEFT SIDE

Exterior Mirror Heating Switch



The outside rear view mirror heating is activated when the lower part of the key is pressed. It is deactivated when pressed a second time

Line Plate Switch



The line plate is activated when the lower part of the switch is pressed, deactivated when the upper part is pressed.

LCD Display Switch



Pressing the lower part of the switch turns on the LCD screen. The LCD screen turns off when the top of the switch is pressed.

Interior Light Switch



When the switch is pressed, the interior lighting sends a command to turn on stages 1 and 2.

Driver Light Switch



When the key is pressed, the driver lamp is activated.

Windshield Heating Switch



When the switch is pressed, the windshield heating is activated. Heating works as 8 minutes of operation - 4 minutes of standby. During this 4-minute waiting period, the driver cannot operate the system again, even if he wishes.

Steering Switch



Steering adjustment is activated when the key is pressed.

Air Conditioning Switch



The A/C setting is activated when the button is pressed.

Flasher Switch



Pressing the lower part of the switch turns on the flasher, pressing the upper part turns the flasher off. When the flasher is on, the indicator lamps on the instrument panel and the function lamp in the key come on and an audible warning is given along with all the vehicle's turn signal lamps.

Headlight switch



Auto: Automatically activates/deactivates the dipped beam headlights in dark/light environments.

Park: Sends the command to activate the parking lights.

Dipped Beam: Sends the command to activate the dipped beam.

Front Fog: Sends the front fog activation command.

Emergency Key

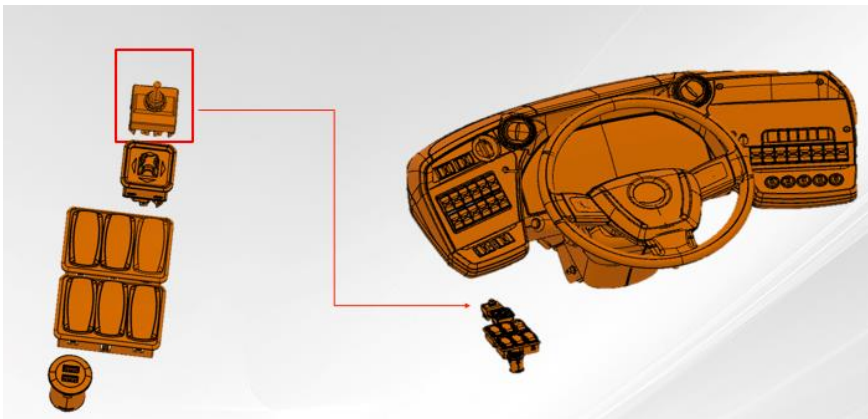

If the emergency key is activated:

- Ceiling lighting II. step becomes active.
- Door step lighting is active.
- Quads become active.
- Driver lighting is active.
- Stewardess lighting is activated.
- Cluster gives audible and visual warning.
- The vehicle's HV system is deactivated.

SWITCHES ON THE RIGHT SIDE



Front Door Button



The front door opens/closes when the key is pressed.

Middle Door Button



The middle door opens/closes when the key is pressed.

Rear Door Button



The rear door opens/closes when the key is pressed.

Middle/Rear Door Button



The middle/rear door opens/closes when the switch is pressed.

Front Door Wing Selection Button

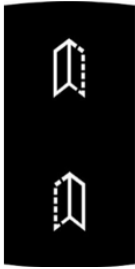

When the key is pressed, it sends the front door leaf selection command.

Kneeling Wrench



The vehicle tilts to the right when the key is pressed.

Vehicle Lowering Lift Switch



When the key is pressed, the vehicle moves up and down.

Stall Brake Switch



If the automatic mode is active, the parking brake will be active in the following conditions;

- Vehicle speed must be below 3 km/h,
- If any door is open,
- If any tailgate is open,
- If the rear engine cover is open,
- If the key is active,
- If the lift is open, the stall brake is active.

The parking brake is disengaged by pressing the accelerator pedal after all doors and covers are closed.

If manual mode is active;

- If the key is active,

- If the lift is open and the vehicle speed is below 3 km/h, the parking brake is activated.
- Automatic or manual selection of the Stall Brake System can be made from the cluster.

Hill Start Assist Switch



It activates or deactivates the hill start system when the key is pressed.

ASR (ESP/ESC) Revocation Key



It is used to activate and deactivate the ASR system.

Retarder Deactivation Button



Sends the command to deactivate retarder function.

Gear Selector (Electric vehicles)



The vehicle can be used in automatic and manual mode. The gear selector features are as follows:

D: Forward gear

N: Neutral

R: Reverse gear

Mode: Performance/economy mode selection

Signal and Wiper Arm



The lever signals to the left when it is down and to the right when it is up. The first turn will activate the intermittent wipers, the second turn the wipers at normal speed, the third turn the high speed wipers. The sprinkler works when pushed towards the steering wheel. The horn is activated when the button on the end is pressed

Signal functions:

1. For the lane change signal, the lever is moved slightly towards the relevant direction.
2. If the right or left signal lights are active and the quad button is pressed, the quads will be active.
3. If the right turn signal light is active and the quad button is pressed, the quads will be active (without turning the quads off), then the right turn signal arm will be active, then the right turn signal light and the right side marker lights will be active.
4. If the left signal lamp is active and the quad button is pressed, the quads will be active (without turning off the quads), then the left signal arm will be passive, then the right lamp and right side marker lamps will be active.
5. If the quads are active and then the right or left turn signal lever is activated, the right or left turn signal lights will be active.



Regenerative Brake Lever

This lever activates the Regenerative brake. The arm consists of 4 stages. You can adjust the braking amount by pulling the lever towards you.



SIDE CONTROL PANEL

Handbrake

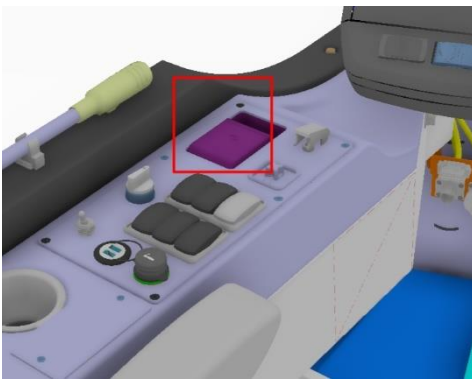

The handbrake system is electronic. The handbrake button is on the left side of the control panel. When the vehicle is stopped, the handbrake button is pressed. Press the button again to release the brake. There is a warning light on the instrument panel that indicates whether the parking brake system is active.

When the handbrake system is activated, the gear shifts to the N position automatically and the gear selector on the LCD screen starts to flash. The gear will stay in the N position even when the handbrake is deactivated. The Drive/Reverse position must be selected again to drive the vehicle. For driving (vehicle active), if the brake air is insufficient (below 6 bar) when the parking brake is disengaged, the warning light turns red. Wait for this light to go out before moving.

Emergency Emergency Brake Release Valve



It is located on the side control console, to the left of the driver. In the event that the vehicle is left without air due to a breakdown on the road, it is held by turning it without releasing the valve with the left hand (it returns to its original position when the handle is released because it is spring loaded), and the vehicle is pulled to the safety lane by holding the steering wheel with the right hand. When the handle is turned, the air reserved in an additional tank is sent to the hand brake bellows, thus releasing the handbrake.

Usb Phone Charger



There is a USB socket charger on the side control panel where the driver can charge his mobile phone. There are two sockets, normal and fast charging.

INDICATOR AND WARNING LIGHTS PANEL

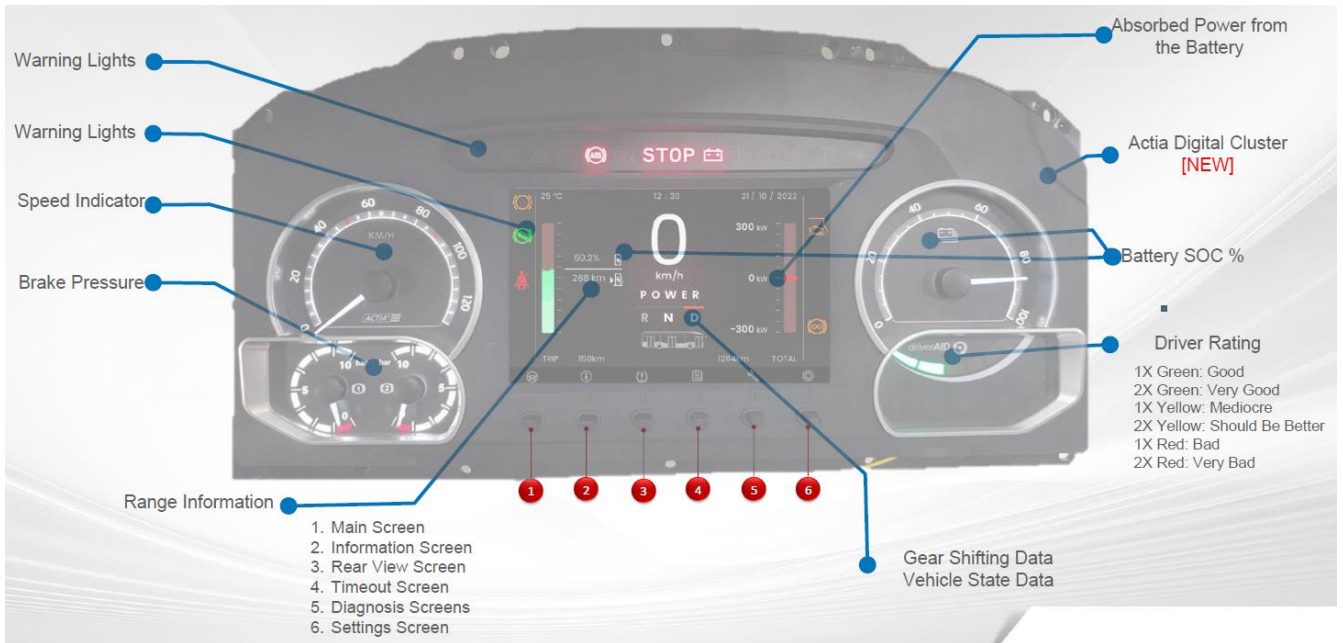











Warning









The vehicle mechanical switch **MUST** be turned off after the cluster sleeps. The shutdown time is specified on the cluster.







Cluster program installation should **DEFINITELY** be done with the ignition off and the parks open.

Cranking is allowed 4 seconds after the ignition is switched on.

	ASR Off	Amber	If the ASR system is disabled, the alert is active.
	ASR On	Amber	If the ASR system is active, the warning is active.
	Brake Lining Warning	Amber	When the thickness of any of the brake pads is low, the warning is active.
	Route Panel Activated	Amber	When the line sign is active, this warning is also active.
	CC Activated	Green	Cruise Control is activated when the on button is pressed.
	ELC Warning	Amber	Orange notice coming from the ELC is a warning. Errors need to be checked from ELC diagnostics. Besides it blinks when the ELC system moves, it is not a breakdown.
	ELC Warning	Red	Red notice coming from the ELC is a warning. Errors need to be checked from ELC diagnostics
	Hillholder Aktivated	Green	If the hill start assist system is activated to be used, the warning is active.
	Battery Management System Amber Warning	Amber	It is active when there is a fault in the high voltage system.
	Battery Management System Amber Warning	Red	It is active when there is a fault in the high voltage system.
	Wheelchair Ramp Open	Red	This warning is active on the screen when the disabled ramp is opened.
	ABS Orange Warning	Amber	It's an amber warning which comes from the brake module. If the warning is activated, the engine must be stopped immediately and errors need to be checked from the ABS diagnostics.
	Electric Motor Warning	Red	Indicates a trouble in the electric motor. The vehicle must be stopped immediately.
	Fire Warning	Red	If the fire detection system is active, it gives a warning. When the warning is active, the vehicle must be stopped immediately.
	Seatbelt Warning	Red	It's a seat belt warning. If the vehicle is under 20km/h, only visual; If it is above, both visual and audible warning will be active.
	Door Valve Warning	Red	If the door emergency valve is open or there is not enough air in the door air system, the warning will be active.

	Steering Wheel Pump Trouble	Red	It is active when a steering pump failure occurs.
	ECAS Red Warning	Red	It is active when there is an error in the ECAS system.
	Engine Lid is Open Warning	Amber	Informs when the engine cover is open.
	EBS Orange Warning	Amber	It is the orange warning alert from the EBS. EBS diagnostics should be checked for errors.
	Air Conditioner is Open Warning	Blue	Gets activated when air conditioner is on.
	Retarder is Activated	Amber	When the foot or arm retarder is active, the warning is active.
	Bus Stop Button	Red	Indicates that passengers want to get off at the next stop. If the back door is open, the stop buttons will not work.

Tell-tale	Icon	Color	Function
1		Amber	It is active when there is a fault in the high voltage line.
2		Red	It is the red warning warning coming from the engine control unit.
3		Green	When the left signal is given, the warning is active.
4		Green	When the right signal is given, the warning is active.
5		Red	When the handbrake is active, the alert is active.
6		Blue	When the high beams are active, the warning is active.
7		Green	When the door brake (Station brake) is active, the warning is active.
8		Green	When the dipped beam headlights are active, the warning is active.

9		Amber	Gets activated when the back fog lights are on.
10		Green	Gets activated when the front fog lights are on.
11		Red	Gets activated when the vehicle is getting charged.
12		Red	It's a driver warning which comes from the motor control unit. Errors must be checked from the motor diagnostic.
13		Red	It's a red brake warning from the brake module. If it is active, motor must be stopped and the errors should be checked from the ABS diagnostic.
14		Red	It's a warning for motor water temperature. If it is active, motor must be stopped and the errors should be checked from the motor diagnostic.
15		Amber	It's activated if the fuel level is low. The vehicle needs to be refueled as soon as possible.

Engine Speed Indicator



The engine rev counter measures the engine revolutions per minute. Starts when the engine is started.

Speed (km/h) Indicator



Shows the speed of the vehicle in kilometers / hour, starts to work after the vehicle moves.

Brake Pressure Gauges: It shows the value of front brake and rear brake air pressures.



- 1- Front brake pressure indicator
- 2- Rear brake pressure indicator

Main Monitor

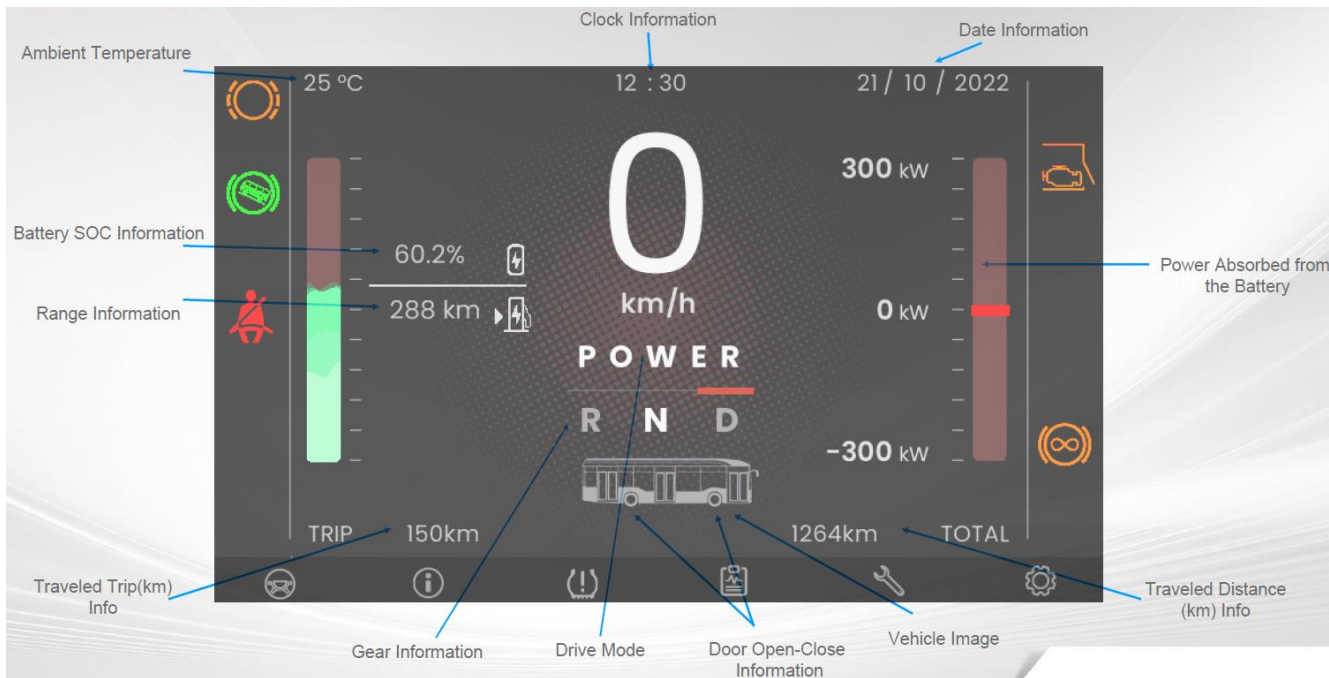

Information Display

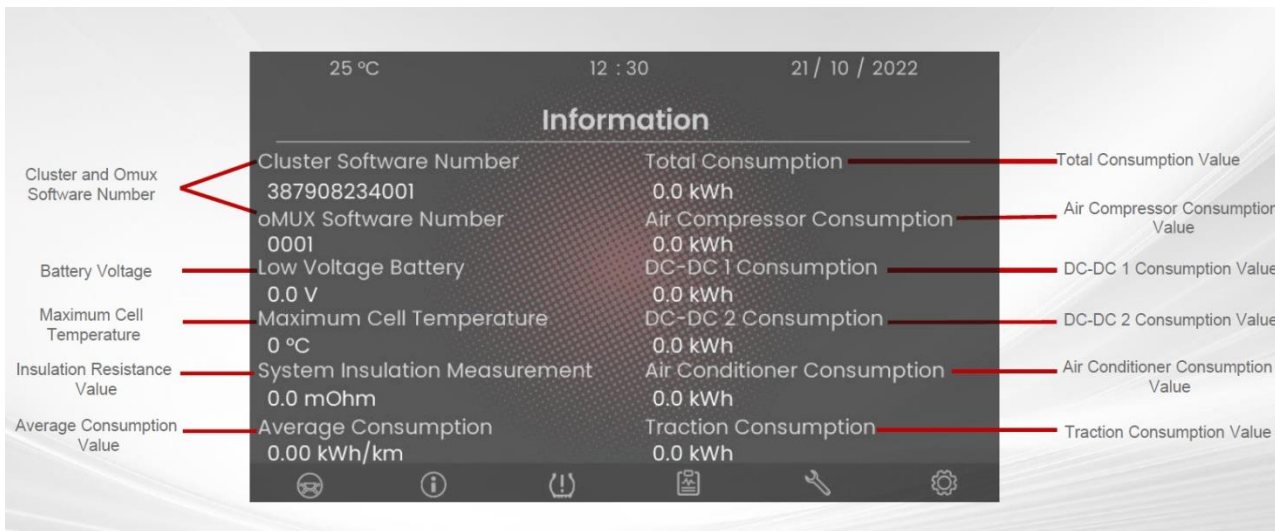

Rear View Camera Screen

The backup camera screen will be on the cluster screen.

If the driver wishes, he can activate the rear view camera by pressing the button.



Timeouts Screen

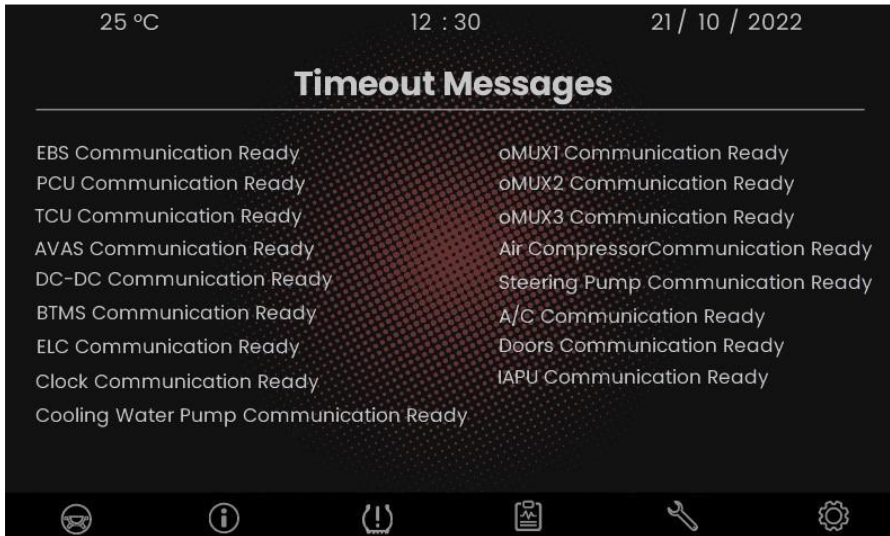

If there is a problem in the canbus line with the systems specified in the vehicle, it gives a warning. (Systems that are not in the vehicle will not appear on the timeout page.)

Bakım Ekranı

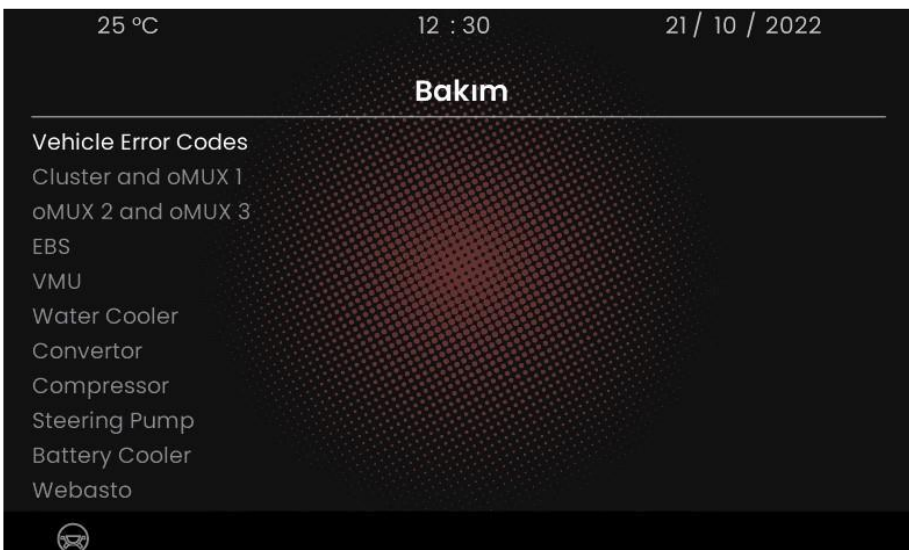

Vehicle Error Codes
Cluster and oMUX1
oMUX2 and oMUX3
EBS Error Codes
VMU Error Codes
Water Cooler Error Codes
DC/DC Converter Error Codes
Compressor Error Codes
Steering Pump Error Codes
Battery Cooler Error Codes
Webasto Error Codes

Setting Screen

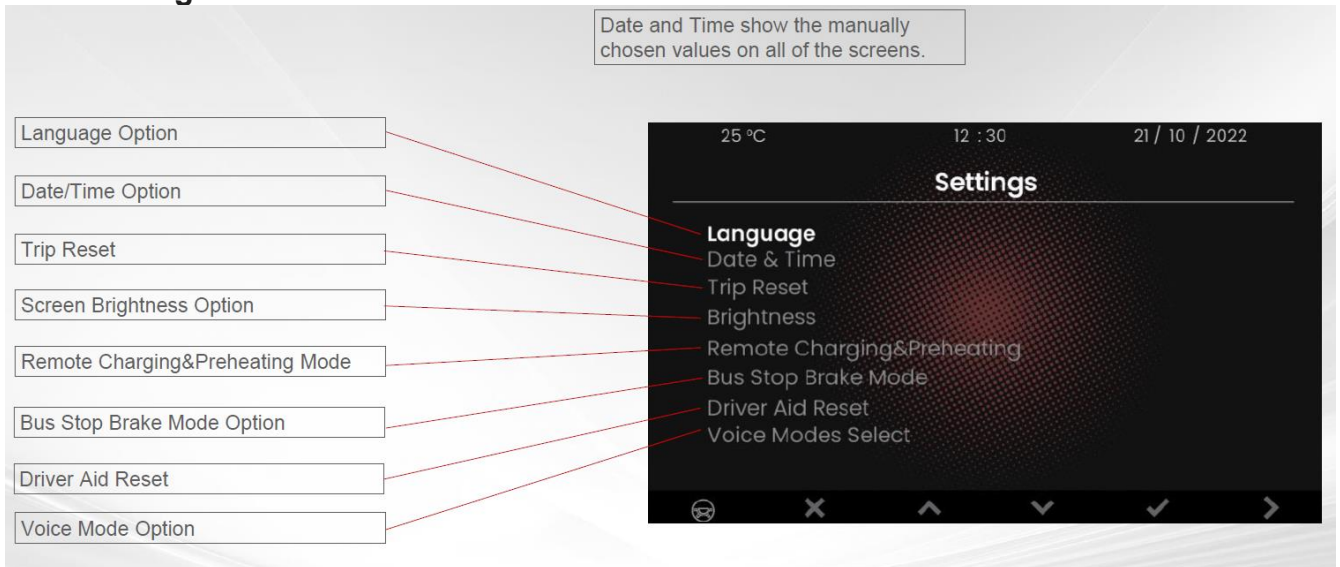

LINE BOARD CONTROL PANEL



The line plate control panel is located in the driver's compartment upper console. The route information to be displayed on the line plate is selected/changed via the control panel.

4. VEHICLE EQUIPMENT

DRIVER SEAT

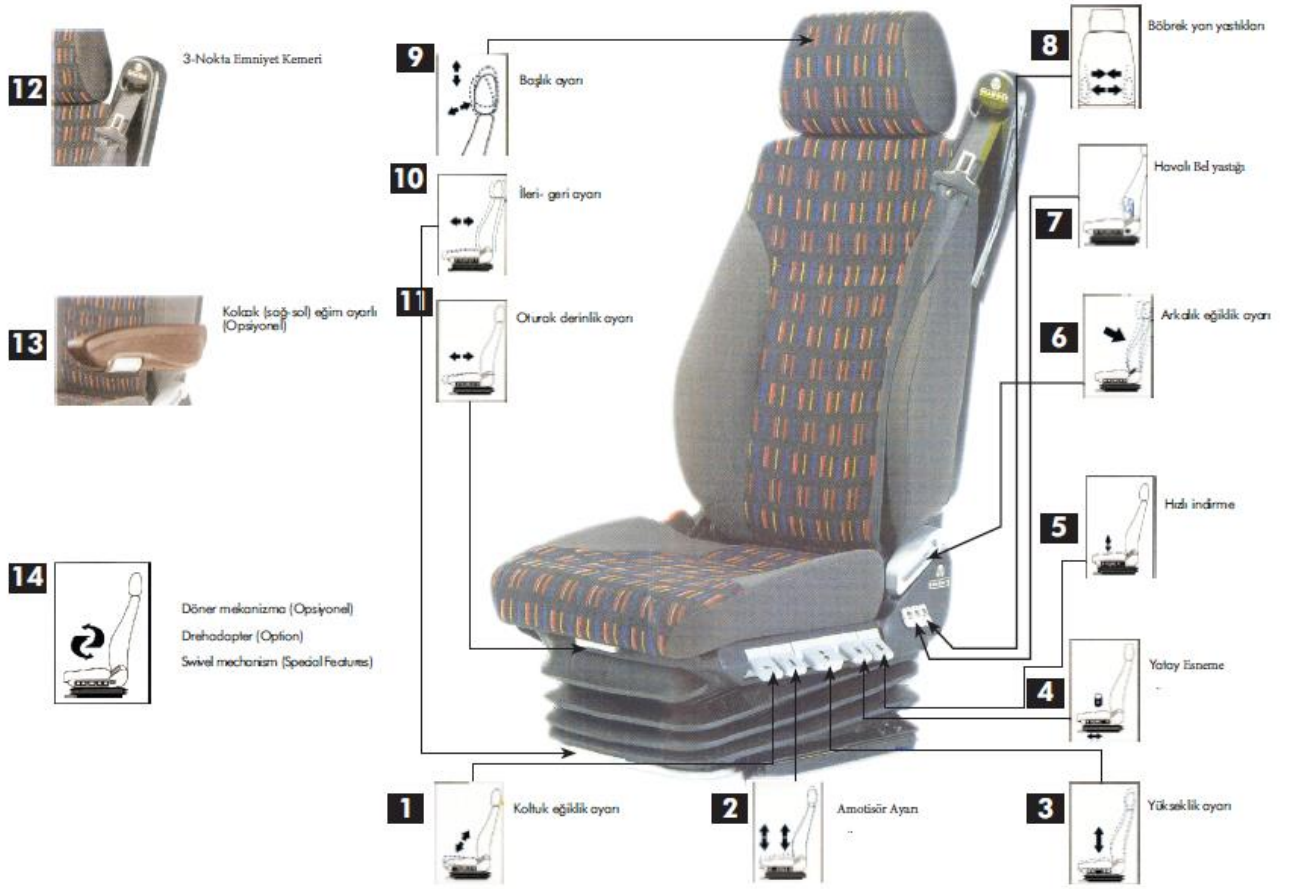

- 1- **Seat Tilt Adjustment:** Seat tilt can be adjusted between 2° and 12°.
- 2- **Shock Absorber Adjustment:** It can be adjusted in 4 steps from soft to hard with the damper adjustment button. It changes to hard position upwards and soft position downwards.
- 3- **Height Adjustment:** With the height adjustment button, it can be adjusted more or less steplessly with in 100 mm.
- 4- **Horizontal Stretch setting:** The button changes to “open” up and “locked” down.
- 5- **Fast Download Setting:** It provides ease of getting on and off.
- 6- **Backrest Tilt Adjustment:** Lean against the backrest. Pull the lever up and move the backrest to the desired position and release the lever.
- 7- **Air Lumbar Pillow:** It can be adjusted to the desired position steplessly.
- 8- **Kidney Side Pads:** The kidney pad can be adjusted according to the user's request. With the (+) button, the pillow is filled with air. With (-) the air in the pillow is discharged.
- 9- **Head Adjustment:** Its height and inclination can be adjusted as desired.
- 10- **Forward - Backward Adjustment:** It can be adjusted back and forth within 210 mm with 10 mm intervals.
- 11- **Seat Depth Adjustment:** It provides 5-stage adjustment within 60 mm.
- 12- **3-Point Seat Belt:** Always wear your seat belts.
- 13- **Armrest (Right - Left) Tilt Adjustable:** By turning the adjustment button, its inclination can be adjusted steplessly. It can be easily folded up when getting on and off.
- 14- **Rotating Mechanism:** Provides ease of getting on and off.

PASSENGER SEATS

There are 28 passenger seats in the standard of the vehicle. Passenger seats must be upholstered in fabric. For disabled passengers, there is a wheelchair area opposite the middle door.

28 (S)

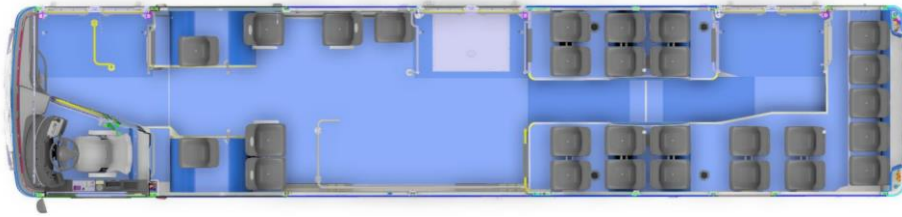

34 + 3 (O)

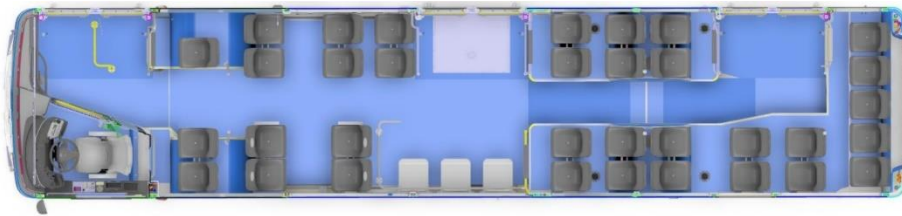

DIGITAL CLOCK



There is a digital clock at the front of the vehicle. Time and air temperature are displayed alternately on the screen. In addition, when the stop button is pressed, the text "TO STOP" is displayed. Hour adjustment can be made from the left buttons, and minute adjustments can be made from the right buttons.

WINDSCREEN BLINDS (Electric Controlled) (Option)

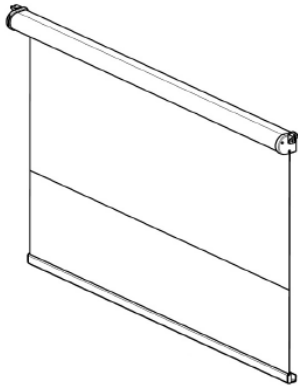

On the windshield, there is an electrically controlled roller blind on the driver's side. There is an electrical connection cable on the left side of the roller blind. Up and down movement of the curtain is provided with the motorized curtain button on the left side of the driver's cabin.

DRIVER'S SIDE ROLLER BLINDS (Option)

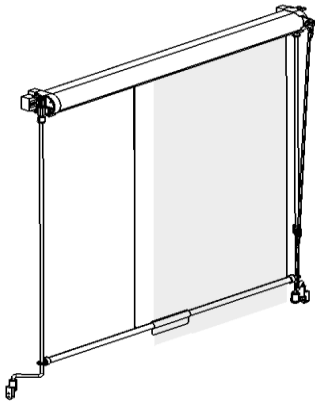

There is 1 roller blind with manual control on the left window on the driver's side. Up and down movement of the curtain is provided with 1 rope on the roller blind.

DVD Player



There is a radio & MP3 player in the vehicle, it has USB and AUX inputs. 30 radio channels can be stored in memory. There is an external remote control in the vehicle.

HEATING AND COOLING SYSTEM



Driver seat

Passenger Compartment

1. Fresh air/ recirculation button
2. Air direction control
3. Fan speed control
4. Temperature control
5. Fresh air / air recirculation button (optional)
6. Fan speed button (optional)
7. Heater button
8. Timer button heater
9. Reheat (dehumidify) button (optional)
10. Auto mode button
11. Temperature button
12. UP/DOWN button
13. Display

The driver operates the device via the keyboard (for operating programming of the air conditioner) and numeric display (for fault status visualization) on the control panel (SC1000).

Enable/Disable System

The control panel opens automatically when the user activates the ignition switch. When enabled, the screen is illuminated.

Temperatures

By pressing the button, the Display can show different temperatures (depending on whether the temperatures are available). The user, can switch from one temperature to another by pressing. The temperature type can be seen on the left side of the screen (see Figure 3). First press will display "outside temperature" and second press will display "inside temperature".





Figure 3 Outside Temperature



Figure 4 Internal Temperature

Adjustment points

Passenger

Yolcu odası için ayar noktası doğrudan  veya  düğmesine basılarak ayarlanabilir. Ayar noktası 1°'lik adımlarla ayarlanabilir.

Driver

It is not displayed because there is no drive setpoint temperature. This means that the setpoint adjustment knob for the driver sets the opening of the hot water valve, not a temperature. This causes an uncontrolled temperature output. There is no algorithm that limits the outlet temperature and sets it to a comfortable value. The driver is fully responsible for his or her own “feel good”. If the passenger room is also in cooling mode, the driver can only activate the cooling mode for the front box. Since there is only one compressor and priority is in the passenger room, the passenger room control algorithm decides whether the compressor will be activated or not. Therefore, without a cooling mode for the passenger room, there is no cooling mode for the front box either.

Fan Speed

Passenger

There is an automatic mode and a manual mode for the passenger fan, with some general restrictions for both modes:

- If the motor is not running, the fan speed of the fans is limited to a configurable value.
- Opening the vehicle's doors also causes the fan speed to be limited while the doors are open.
- It is not possible to set the speed of the blowers to zero during cooling (with the compressor running). The minimum fan speed is set automatically.

Manual variation: The fans,  be set to manual mode by pressing the button. The actual speed of the blowers is now shown on the display and the value can be adjusted by pressing the and buttons. Values change from 0% to 100% in 10% steps. If the

system is in cooling mode, the minimum blower speed is set to a minimum value, not 0% (configuration dependent). There is no other limitation for manual blower speed change.

The red light on the fan button () indicates that the blowers are operating in manual mode and the blower speed is stable (not controlled by the control algorithm).

Press for a few seconds to disable  manual ventilation, then the red light of the button will disappear.



Automatic variation: The automatic variation of the blower speed is calculated from the control algorithm according to various temperature and parameters. There are several limitations to the blower speed described below.

Driver

Front box fan speed is always set manually, there is no automatic mode. Below you can find some restrictions for fan speed:

- Without a running motor, the blower is off
- Minimum fan speed is 15% if compressor is running
- Fan speed is set to maximum if defrost is active

Auto Mod

 Buton üzerindeki kırmızı led otomatik modun aktif olduğunu gösterir. "Otomatik" modu düğmesine  basılarak ayarlanabilir/kaldırılabilir. "Otomatik" modu devre dışı bırakılırsa yolcu odası için yalnızca havalandırma sağlanır.  Düğmeye uzun basılırsa sistem kapanacak ve hiçbir işlem gerçekleştirilmeyecektir.

Compressor Activation

The compressor is activated when all of the following conditions are met:

- The set point of the outlet temperature is equal to or lower than the room set point
- Setpoint of outlet temperature is equal to or less than -1K outdoor temperature
- Outside temperature equal to or higher than 8°C
- The engine is running
- No high pressure fault, no low pressure fault and no icing fault

The compressor is disabled when one of the following conditions is met:





- Setpoint of outlet temperature equal to or greater than room setpoint + 2K
- The set point of the outlet temperature is equal to or higher than the outside temperature + 5K
- Outside temperature equal to or lower than 8°C
- The engine will not start

- High pressure fault, low pressure fault or icing fault

If the compressor is activated continuously for 1 hour, the clutch is released for 1 minute to prevent clutch failures.

Driver's Air Direction

The driver can select the air outlet direction for the front air conditioner. The driver can set the following output directions:

Air Direction	
	To floor
	To floor, driver and windshield
	Only windshield
	Defogger: Maximum blower speed Maximum heating Only windshield
	

Actual air distribution may vary and is dependent on optional front box.

Drive Temperature Setting

The outlet temperature of the front box is not controlled, which means the driver has to adjust the temperature however he feels comfortable. Via the knob, the driver can only adjust the opening of the water valve. Depends on the cooling system state. If the passenger room is in cooling mode, the front box is also in cooling mode

Fresh Air Recirculation

Driver

Driver fresh air is always on and can be manually adjusted to recirculated air by pressing the left side.  The red led on the button indicates that the front box is indeed in circulation mode (led on) or fresh air mode (led off). Recirculation air for the driver is not

limited by time.

Passenger





The fresh air opening is automatically controlled based on the set point, the duct set point and the outside temperature. Cycle air can be activated manually by pressing  the right side. The maximum time for recirculating air in the passenger room is limited to 10 minutes. At the end of this period, the fresh air inlets are controlled automatically.

Error

In case of malfunction, the icon on the display flashes. All faults must be followed by CAN messages from the Vehicle.



Error symbol

The user can enter the error screen by long pressing (button 1) . The following screen will appear on the screen and the user will need to enter the password [1 1 1 1]. The digits can be increased or decreased with  or  (button 12) and move to the next number with (button 11) .



Error Screen

After entering the error screen, the user has the opportunity to see 2 different error types:

- **Active Error:** There is still a malfunction in the system. If there is a dot symbol "." If it is between the 3rd and 4th digits, the error is active, otherwise the error is inactive. Figure 12 is an active sample error.
- **Passive Error:** Failure does not exist, but has occurred in the past. It can be seen how many times the error occurred with the counter in the lower right part of the screen.



Figure 5 Errors

There are two groups of errors in this system: RTU (Roof Top Unit) & Frontbox Errors. They can be seen in the table below.

ErrorCode (Display)	Name	CAN Name (VTB_RTU_ERR)	Description
01.01	Inp_bError_ApplicationType_Adressing	Error_ApplicationAddressing	
01.02	Inp_bError_HVACTypeAdressing		
01.03	Inp_bError_CANOff	Error_CAN	Vehicle CAN Error
01.04	Inp_bError_EmergStop		
01.05	Inp_bError_T_Ambient	Error_AmbientTemperatureSensor	Ambient (Outside) Temperature Sensor Error
01.06	Inp_bError_T_Duct	Error_DuctTemperatureSensor	Duct Temperature Sensor defect
01.07	Inp_bError_T_Room	Error_RoomTemperatureSensor	Room temperature sensor Error
01.08	Inp_bError_T_Ice	Error_IceTemperatureSensor	Evaporator Temperature Sensor Error
01.09	Inp_bError_P_High	Error_HighPressureSensor	Yüksek Basınç Sensörü hatası
01.10	Inp_bError_P_Low	Error_LowPressureSensor	Low Pressure Sensor defect
01.11	Inp_bError_Heater		
01.12	Inp_bError_CompressorALimitInfo		
01.13	Inp_bError_CompressorBLimitInfo		
01.14	Inp_bError_Motor1	Error_Motor1	Fresh Air Flap Left motor error
01.15	Inp_bError_Motor2	Error_Motor2	Fresh Air Flap Right motor error
01.16	Inp_bError_Motor3	Error_Motor3	Roof Heating Valve motor error
01.17	Inp_bError_Motor4	Error_Motor4	Floor Heating Valve motor error
01.18	Inp_bError_SLIVTooHigh		
01.19	Inp_bError_Undervoltage	Failure_UndervoltageSLI	
01.20	Inp_bError_CompressorACommonEDS	Failure_Compressor1Feedback	
01.21	Inp_bError_CompressorBCommonEDS		
01.22	Inp_bError_CompressorAInverter	Failure_Inverter1	

01.23	Inp_bError_CompressorBInverter		
01.24	Inp_bError_CompressorHighPressure	Failure_HighSystemPressure	
01.25	Inp_bError_CompressorLowPressure	Failure_LowSystemPressure	
01.26	Inp_bError_CompressorALimit		
01.27	Inp_bError_CompressorBLimit		
01.28	Inp_bError_CompressorIcing	Failure_Icing	
01.29	Inp_bError_HVTooHigh		
01.30	Inp_bError_UndervoltageHV	Failure_UndervoltageHV	
01.31	Inp_bError_T_Floor_1		Floor Temperature Sensor 1 defect
01.32	Inp_bError_T_Floor_2		Floor Temperature Sensor 2 defect
01.33	Inp_bError_T_Coolant_1		Coolant (water) Temperature sensor 1 defect
01.34	Inp_bError_T_Coolant_2		Coolant (water) Temperature sensor 2 defect
01.35	Inp_bError_PTCAOvertemp		PTC 1 Overtemperature
01.36	Inp_bError_PTCBOvertemp		PTC 2 Overtemperature
01.37	Inp_bError_Slave		
01.38	Inp_bError_Tice_local		
01.39	Inp_bError_Undervoltage_local		
01.40	Inp_bError_T_InnerHX		Co2
01.41	Inp_bError_T_OuterHX		Co2
01.42	Inp_bError_SwitchingValve		Co2
01.43	Inp_bError_HVACCAN		internal CAN Error

Ön Isıtıcı Hata Grubu

ErrorCode (Display)	Name	CAN Name (VTBS_FB_ERR)	Description
03.01			Not implemented
03.02	Room Sensor Error	FB_Error_RoomTempSensor	Not implemented
03.03	Coolant Valve Error	FB_Error_WaterValve	
03.04	Lower Duct motor Error	FB_Error_FeetDuctFlapMotor	
03.05	Upper Duct motor error	FB_Error_HeadDuctFlapMotor	
03.06	Fresh Air motor error	FB_Error_RecirculationFlapMotor	
03.07	Defrost motor error	FB_Error_DefrostFlapMotor	
03.08			Not implemented
03.09			Not implemented

DIGITAL TACHOGRAPH (Option)

The tachograph records the speed of the vehicle, the time traveled, the distance and other information. Tachograph can assist in achieving economical driving and optimal management of operations.

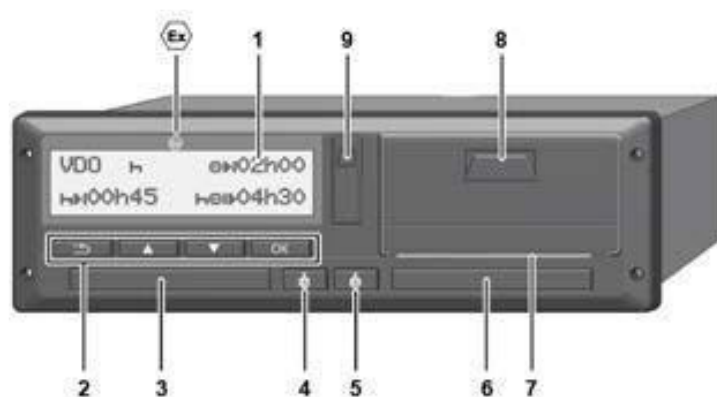

No.	Name
1	Screen
2	Menu buttons
3	Card slot 1
4	Driver combination button - 1
5	Driver combination switch-2
6	Card slot 2
7	Cutting edge
8	Printer slot
9	Front interface
	Label for ADR version (old)

Led Screen

The contrast and brightness of the screen cannot be changed.

Menu Buttons

Please use the buttons below to enter, view or print data;

/ Press the button of the desired direction several times. Scroll to the desired function at the menu level.

Press and hold button: Automatically scroll.

OK Press the button briefly. Confirm function / selection.

Return Press the button briefly. Return to the previous entry field, cancel the country entry or exit the menu levels step by step.

Card slot 1

Driver 1 to drive the vehicle inserts the driver card into card slot 1.

Driver combination button - 1

Driver combination button - 1 Press the button briefly. Change the activity. Press and hold the button. (a least 2 seconds) Open the card slot.

Drive combination switch - 2

Drive combination switch - 2 Press the button briefly. Change the activity. Press and hold the button (at least 2 seconds). Open the card drawer.

Card slot 2

Driver 2, who is not currently driving, places the driver card in drawer 2 (crew operation).

Cutting edge

You can tear the printer's paper output from the tear-off edge.

Printer slot.

Printer drawer for placing the paper roll.

Front interface

Downloading of data and parameterization is done via the front interface (workshop). The front interface is located under a cover. Access rights to the functions of this interface depend on the inserted tachograph card.

DIAGNOSTIC SOCKET

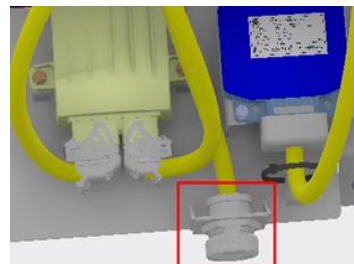
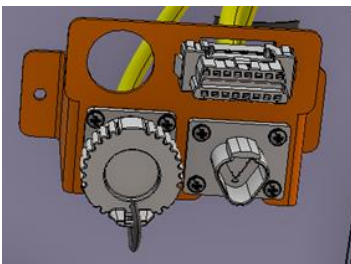

The diagnostic socket is positioned in two different places, one at the front and one at the back. It is located in the lower left part of the front diagnostic glove box, at the driver's knee level. On the rear side, it is located on the left rear side of the vehicle, in the area where the control units are located. This socket is used to connect to the lifelines in the vehicle and to load, change and diagnose parameters to the engine control unit.

MIRRORS

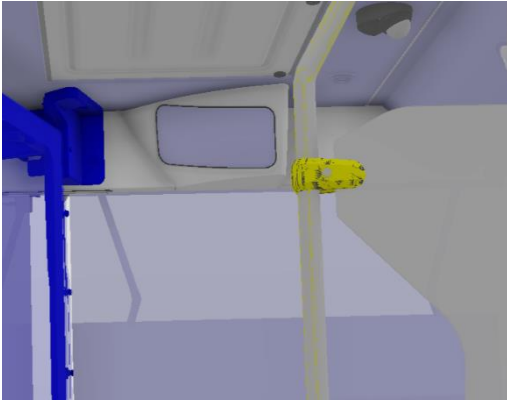

There is one interior rear view mirror inside the vehicle.

Outside, there are two outside rear view mirrors, one on the right and one on the left.



Left Outside Rear View Mirror



Right Outside Rear View Mirror

DASH CAMERA (OPTION).

There are 8 cameras in total in the vehicle. On the right side of the driver, there is a monitor on the front panel, thanks to this monitor, the driver can follow the entrance and exit of the passengers with the images reflected from the cameras.

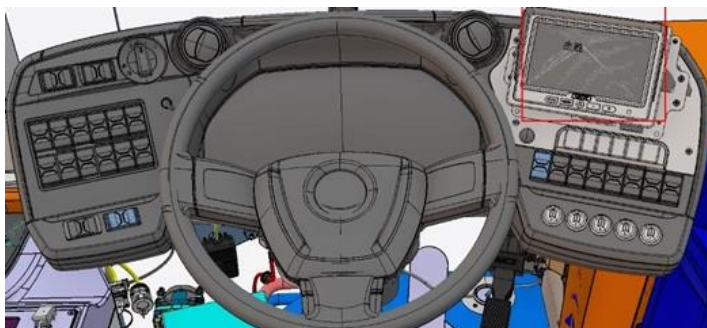

REAR VIEW CAMERA SYSTEM (OPTION)



There is a closed circuit camera system that monitors the rear of the vehicle when parking or reversing. Images from the camera can be viewed on the LCD screen on the front control panel.

MOBILE DVR (Digital Recorder-OPTION)



The DVR is top mounted in the driver's compartment. The DVR allows recording of audio and video captured with the camera. Mobile DVR (Digital Video Recorder) provides powerful monitoring functions, including audio and video encoding and decoding, 2G, 3G and Wi-Fi wireless network transmission,

satellite positioning service. Safe data storage, hard disk vibration damping. It can work both as a stand-alone recorder or collaborate with other devices to create a comprehensive surveillance system.

DIGITAL LINE PLATE

There is 1 digital line plate in the front, side and rear of the vehicle.

HANDLES

There are grab handles on the pipes for the passengers in the vehicle to hold on.



STOP BUTTONS

There are three types of stop buttons in the vehicle.

Standart



For disabled passengers



For priority passengers



Passengers who want to get out of the vehicle inform the driver by pressing these buttons. The relevant door button lights up and the digital clock displays "STOP". In addition, the audible warning is also activated. When the doors are opened, the word "STOP" and the warning lights on the door turn off.

WHEELCHAIR SPACE



There is a special area opposite the middle door so that the passenger in a wheelchair can travel safely.

DISABLED PASSENGER RAMP

There is a manual opening/closing ramp at the rear door for comfortable vehicle entry/exit for disabled passengers in wheelchairs.

Using the Ramp

When a disabled passenger who wants to get into the vehicle

presses the  button, the  warning is given. In this situation,

Stop the vehicle at a point where traffic is convenient.

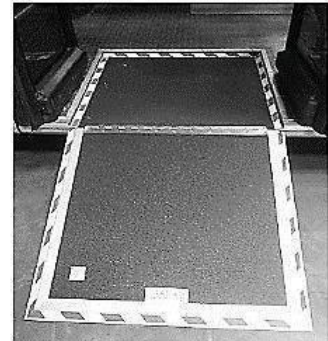
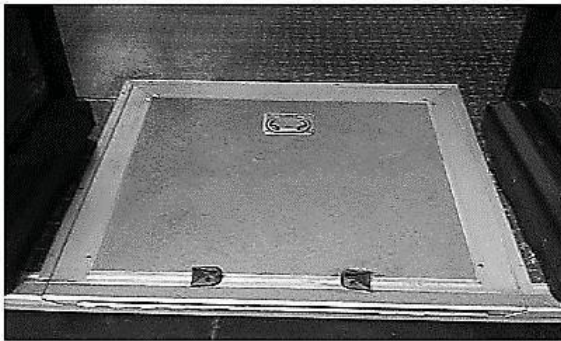

- Open the back door.
- Open the ramp by holding the handle and push it out of the vehicle.
- Have the disabled passenger get on/off.
- Close the ramp by folding it towards the inside of the vehicle.

When the ramp is open,  (back door open) warning light comes on. Disabled passenger symbol is seen on the information screen. In addition, an audible warning is heard



STEERING ADJUSTMENT

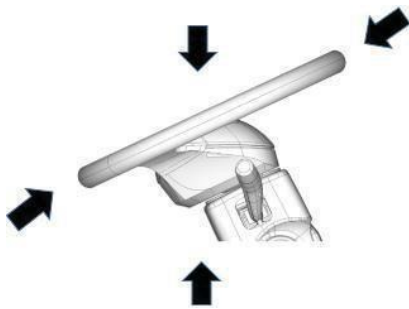

Steering is inclined and telescopic. For this adjustment, pull the lever on the left under the steering wheel towards you. When the desired position is reached, the lever is pushed back.

HORN

The horn sounds when the center of the steering wheel and the horn button on the turn signal lever are pressed.

PEDALS

In electric motor vehicle;

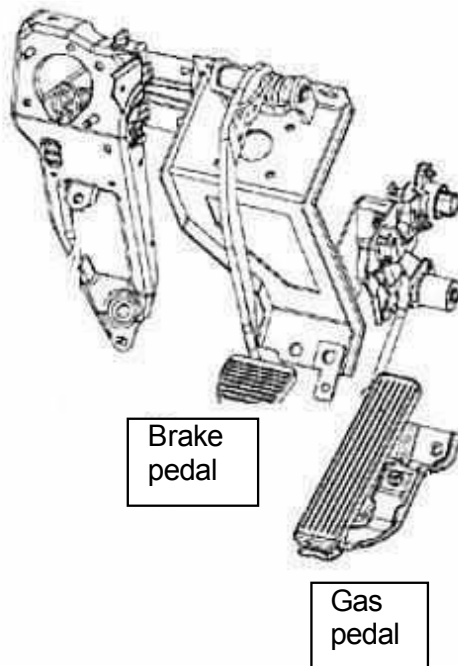

Brake pedal

When the brake pedal is pressed, an electrical signal is given to the respective control units and air is distributed to the brake elements. It is integrated into the vehicle's brake system and will operate when the brake pedal is pressed.

Gas Pedal

The pedal on the right is the accelerator pedal. The electronic signal sent by the position sensor connected to the accelerator pedal is evaluated by the ECU (Electronic Control Unit) and the signal going to the electric motor and the vehicle speed vary.

ELECTRICAL ELECTRONIC SYSTEM AND HIGH VOLTAGE COMPONENTS

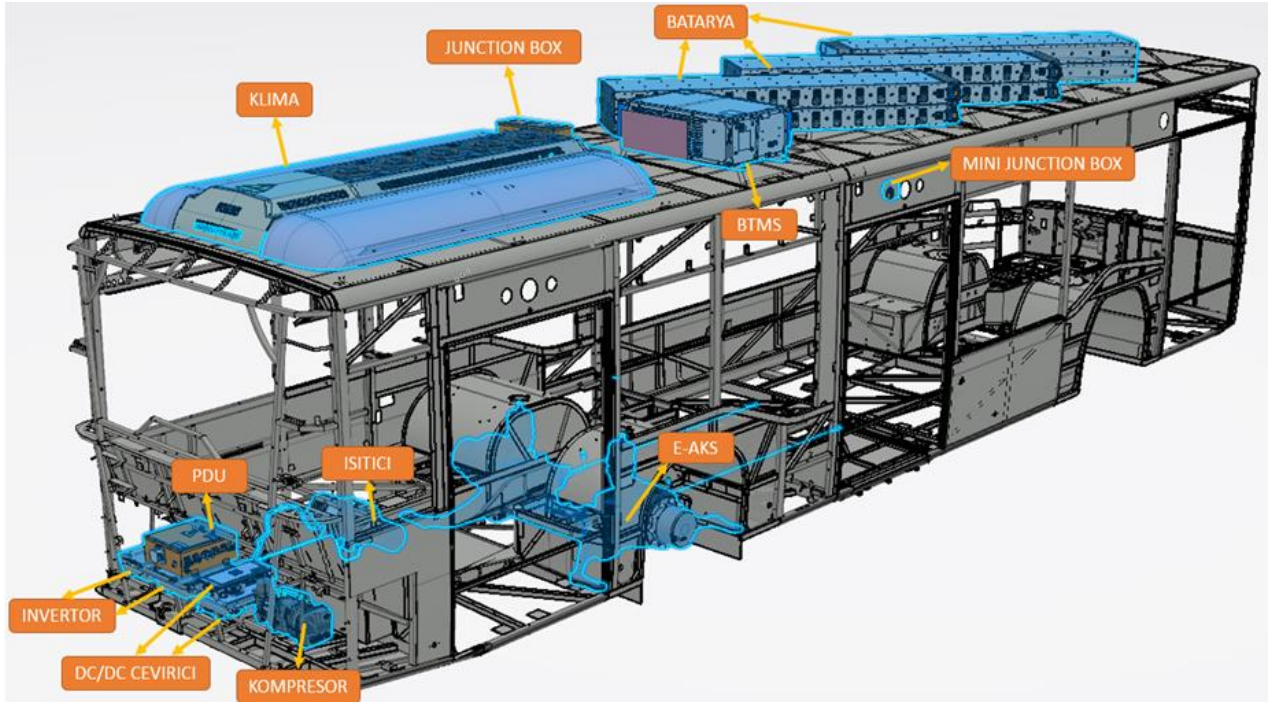

The locations of the electronic and power group components on the vehicle are as follows.

ATTENTION!

No intervention should be made on the electrical electronic system and high-voltage components, except by authorized personnel / service.

High voltage!

Vital danger!

- Never touch the HV cables or HV connections without first making sure that there is no voltage!
- The device may only be connected by a qualified electrician!
- Security installations should never be bypassed or bypassed! Any malfunction that occurs can lead to life-threatening consequences!
- Never connect the device to a socket without a protective earth conductor!

When working on an HV system, the following 5 safety rules must be strictly followed:

- Disconnect the system from power.
- Turn off the ignition.
- Remove the service/maintenance plug and/or turn off the main battery switch.
- Remove the fuse.
- Make sure that the system cannot be reactivated.
- Keep the ignition key safe to prevent unauthorized access.
- Keep the service/maintenance plug secure to prevent unauthorized access and/or use a lockable cover to ensure that the main battery switch cannot be reactivated.
- Make sure the devices are de-energized using a suitable voltage tester (note the voltage range!).
- Ground and short-circuit the system.
- Secure or insulate adjacent moving parts.

ELEKTRİK SİSTEMİ (OPSIYON-1)

Rated Voltage: 660 V

Battery Type: NMC

Battery Capacity: 225 kWh

Range : 240 km'ye kadar (A/C olmadan)

160 km'ye kadar (w A/C)

ELEKTRİK SİSTEMİ (OPSIYON-2)

Rated Voltage: 660 V

Battery Type: NMC

Battery Capacity: 300 kWh

Range: 320 km'ye kadar (A/C olmadan)

210 km'ye kadar (w A/C)

ELECTRICAL SYSTEM (OPTION-3)

Rated Voltage: 660 V

Battery Type: NMC

Battery Capacity: 375 kWh

Range : 400 km'ye kadar (A/C olmadan)
260 km'ye kadar (w A/C)

ELECTRICAL SYSTEM (OPTION-4)

Rated Voltage: 660 V

Battery Type: NMC

Battery Capacity: 450 kWh

Range: 480 km'ye kadar (A/C olmadan)
310 km'ye kadar (w A/C)



BATTERY SYSTEM

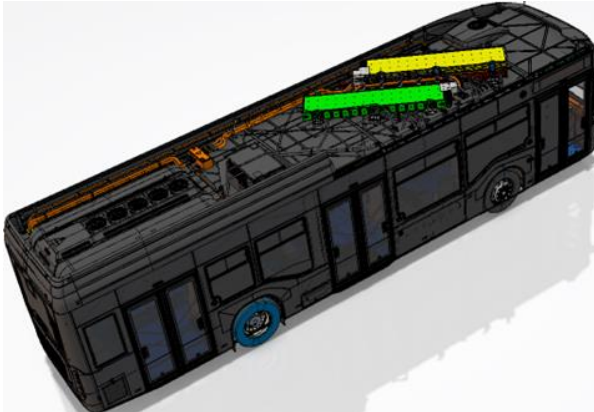

Battery Capacity: 225 kWh

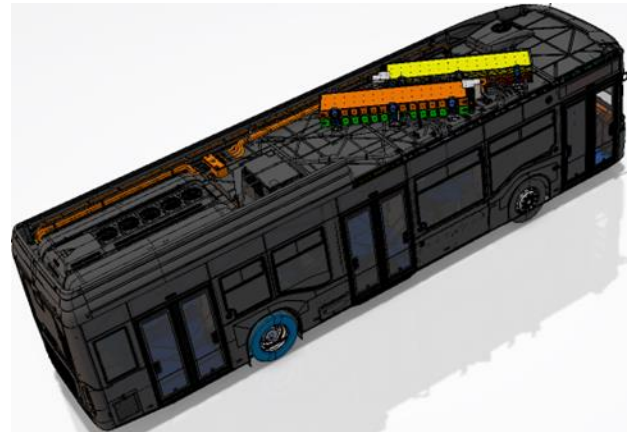

Battery Capacity: 300 kWh

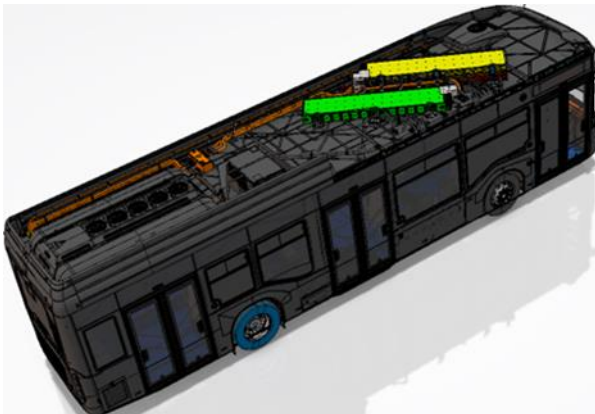

Battery Capacity: 375 kWh

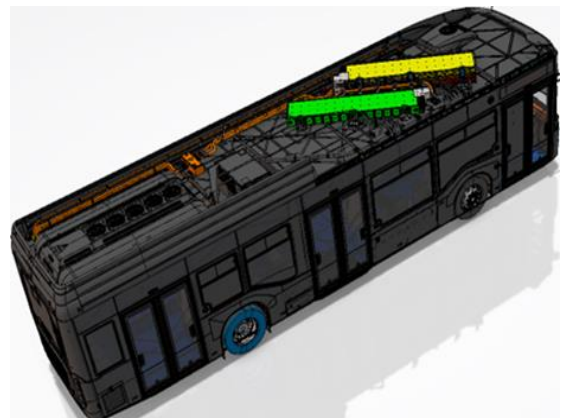

Battery Capacity: 450 kWh

CITI VOLT is extremely safe with its technological battery system.

The high voltage battery unit is the energy storage device for the electric motor. The high voltage battery is charged when the electric machine is operated as an alternator. The high-voltage battery in the vehicle can also be partially charged during braking energy regeneration. However, it is mainly charged using energy from an external power grid. However, this is primarily used to maintain the state of charge when the high voltage battery is already extremely discharged. The range of the vehicle can be increased.

The high-voltage battery of an electric vehicle is equivalent to the fuel tank in an internal combustion engine vehicle. It is energy storage device for electric motor. The amount of energy to be stored in order for the vehicle to reach the desired range is accordingly high, so the volume and weight of the energy storage device are also high. However, some vehicle features were positively affected by the installation of the high-voltage battery pack in the vehicle's Drive module.

- The passenger compartment is not constrained by the high voltage battery pack.
- The high voltage battery pack is easily accessible in the Service, reducing repair costs.
- Insulated and professional tools, insulated gloves and shoes will be used for installation and maintenance.
- Please clean the tools after installation and maintenance, do not put metal objects inside or on the battery system components.
- Before connecting or disconnecting the cable, please make sure that all high and low voltage is disconnected.
- The battery system must be operated with professional tools and protective equipment.
 - Maintenance should be performed by professionals with battery expertise and safety training.
 - The connection between packages should be made with anti-loosening device to prevent loosening, aging and jamming.
 - Avoid any short circuit during the connection process.
 - All connections must be made under clear instruction, any guesswork and vague attempts are strictly prohibited.
 - Important ports: Correct and reliable connection, good contact, no short circuit.
 - All ports must be free of contact or short circuit with other package.
 - Consult ISUZU authorized services for other uncertain factors.

Cable Connections

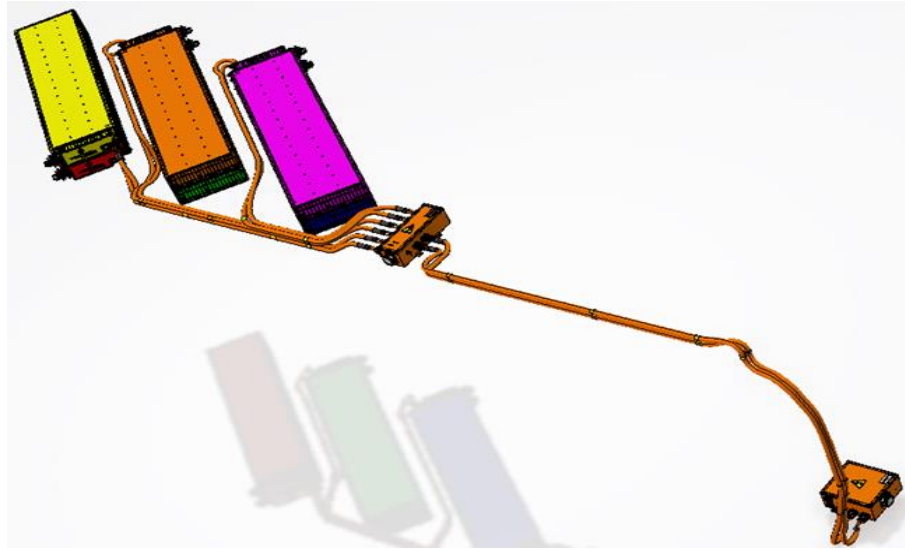

WARNING!

For High Energy type package, the power output is blocked only in one pipe, unused pipe molding stage. When installing the cables, please make sure that the cable label corresponds to the individual package label.

CHARGING STATION SYSTEM , FILLING



Charge Type: DC Tip 2

Charging Power: DC Fişi - 150 kW

	Opsiyon-1	Opsiyon-2
Charging Time: 150 kW –	2.1 saat	2,5 saat

	Opsiyon-3	Opsiyon-4
Charging Time: 150 kW –	3 saat	3.4 saat

NOTE:

DC (Fast) charging is possible through a single socket.

It provides a 10-minute fast charge, up to 30 km without damaging the battery life.

Intelligent energy management provides remote control for charging.

CLUSTER CHARGE END WARNING

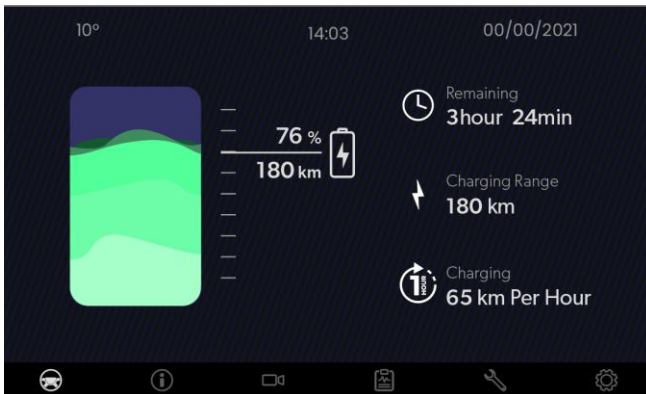

When the charge level drops to 10% and below, the red warning on the side is displayed. In such a case, charge your vehicle at the nearest charging station.

CHARGING TIME

Users can follow the estimated time remaining on the digital display screen during the charging period



USING CABLES AND SOCKETS FOR CHARGING



During the charging process, the CCS type 2 DC charging cables are locked in place electromechanically via a locking actuator integrated into the vehicle charging port. The charging cables comply with the IEC 62196-3 standard and are VDE certified. The charging cable you will use to charge your vehicle must comply with IEC 62196-3 and DIN EN 50620 standards.

DRIVER RATING SYSTEM



The driver will be rated based on his fuel consumption performance.

- 1X Green:** Good
- 2X Green:** Very Good
- 1X Yellow:** Moderately good
- 2X Yellow:** Should be better
- 1X Red:** Bad
- 2X Red:** Awfull

PDU (POWER DISTRIBUTION UNIT)

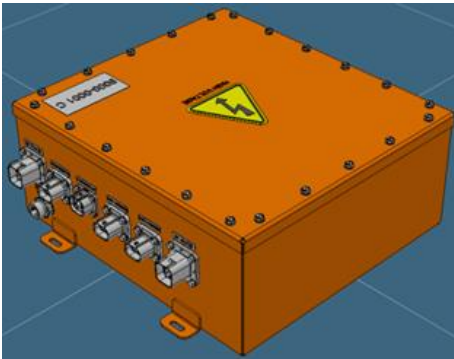

High voltage distribution unit for EV, hybrid power, commercial vehicle, low speed vehicles for current distribution and control of PDU, battery, electric motor, Fast charge, slow charge, air conditioner, heater, DC/DC converter, and more equipment.

QUICK CHARGE CONTROL UNIT (VCCU)

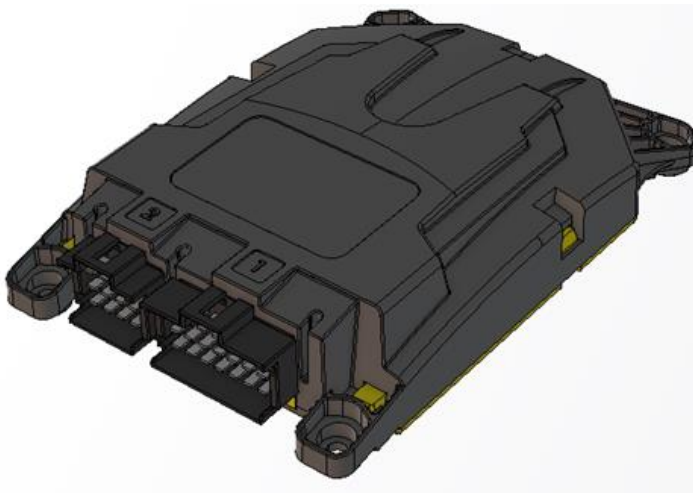

It is the unit that not only controls the high speed charge in the vehicle but also manages the batteries.

DC/DC CONVERTER

It is the unit that converts high voltage (600V) to low voltage (24V) for the supply of 24 Volt batteries in the vehicle. DC/Dc charges the energy from the vehicle's HV battery pack by sending it to the vehicle's 24V battery pack. The DC/Dc will be controlled by the VMU by following the energy capacity of the vehicle's 24V battery pack.



CHARGING SOCKET ON VEHICLE (CCS2)



Input that allows the vehicle to be charged with DC and AC power.

Vehicle Input for charging with alternating current (AC) and direct current (DC), for installation in electric vehicles (EV), CCS type 2, Combined Charging System, IEC 62196-3, 200 A / 1000 V (DC), 32 A / 1000 V (AC), 24 V Charging socket with locking actuator.

COOLING SYSTEM RADIATOR



The cooling system provides cooling of the electric motor driven axle, inverter, DC/DC converter and air compressor components with coolant.

HIGH VOLTAGE HEATERS (HV HEATER)

They are high voltage heaters that feed the heating system that heats the interior of the vehicle and there is 1 on the standard vehicle.

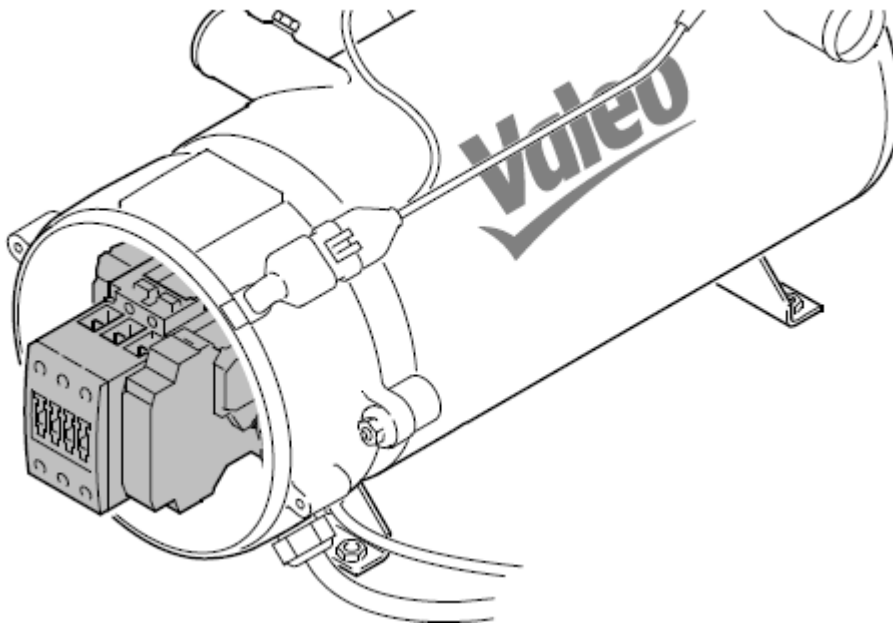

ELECTRIC AXLE

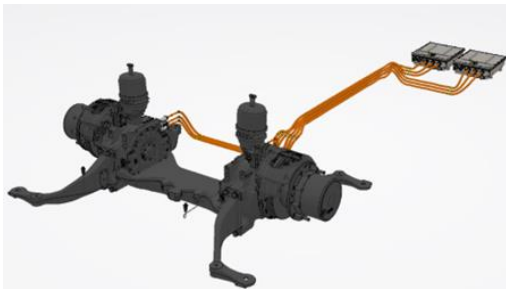

Drive Type	Battery Electric Vehicle
Type	Electric Traction Motor
Model	AVE130
Max Power	250 kW
Max Torque	22000 Nm

AVE 130	
Engine Technology	Two asynchronous motors, three phases
Motorized Model	ZF AVE 130
Drive Type	Direct Drive
Max. Power (kW)	2 x 125 kW
Max. Torque (Nm)	2 x 11,000 Nm
Cooling Type	Liquid Cooling
Brake	Internally ventilated disc brake
Degree of protection	IP6K9K per ISO 20653

Safety instructions

This motor must be installed and operated by qualified personnel who are fully aware of the types of hazards involved in working with electrical circuits and are familiar with standard practices for preventing accidents.



General/Irritant/Operational: This warning symbol indicates that you are in a potentially hazardous situation which could result in damage to the product or in some cases, bodily harm or death.



Electrical: This warning symbol indicates that you are in a potentially hazardous situation which is electrical in nature and which could result in the product or, in some cases, bodily harm or death.

To remind you of the potential hazards involved, this manual and procedures contain appropriate safety warnings that, if done incorrectly, could cause harm to you or the product.

ENGINE CONTROL UNIT (MCU)



The electric motor system is operated via the CAN message exchange between the Motor Control Unit (MCU) and the Vehicle Management Unit (VMU). The VMU is responsible for the user interface and also interfaces with the Battery Management System (BMS) / Power Distribution Unit (PDU) and all other components involved in the vehicle architecture.

Typical VMU and BMS/PDU operations involved in the engine system include:

- Powering the system from the auxiliary battery.
- Acknowledgment of the activation signal (VMU or vehicle ignition).
- Performing high voltage battery precharge (BMS/PDU).
- Applying high voltage battery voltage to the system (BMS/PDU).
- Transmission of CAN messages (VMU) with the MCU:
 - Starting and stopping the system.
 - Application of a mechanical torque.
 - Safe shutdown of the system.
 - Verification of operational status.

Safety warnings on operating the system



Read these general safety warnings before operating the system.

Improper use of the motor control unit can damage the product and/or cause injury or death.

- Do not attempt to open or repair the MCU. Contact ISUZU in case of damaged chassis or suspected product malfunction.
- Use only recommended points for lifting and securing the system. When disassembling and/or installing the MCU, you **MUST NOT**:
 - Do not modify any part of the MCU.
 - Do not apply any external load to the case of the MCU.
- Applying excessive torque or speed when the engine is cold can adversely affect component durability.
- When the engine is used in an environment where the ambient temperature is below 0 °C, it is recommended to avoid excessive speed or torque and to follow a normal driving cycle for the first few minutes until the engine has had a chance to warm up.
- Note: This is a widely applicable best practice for any mechanical equipment. The TM4 engine does not limit performance, full speed and torque is available after a cold start, but is not recommended. The engine can reach very high temperatures that can cause severe burns and/or other injury.
- Avoid contact with surfaces during and immediately after use.

WARNING!

Misuse of this product can cause damage to the vehicle and/or cause injury or death.

- If you use chains, straps, or other means of lifting, make sure they do not touch or exert pressure on any part of the exterior of the product (surface, connectors and/or cables).

Coolant Inlet And Outlet Locations

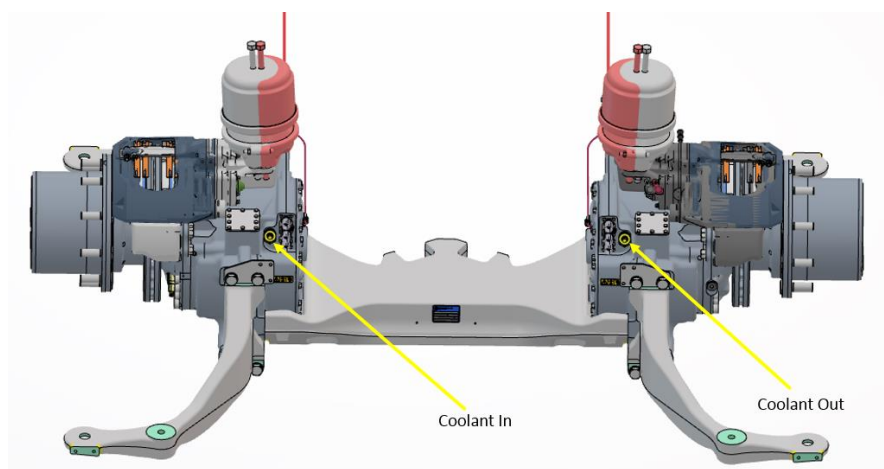

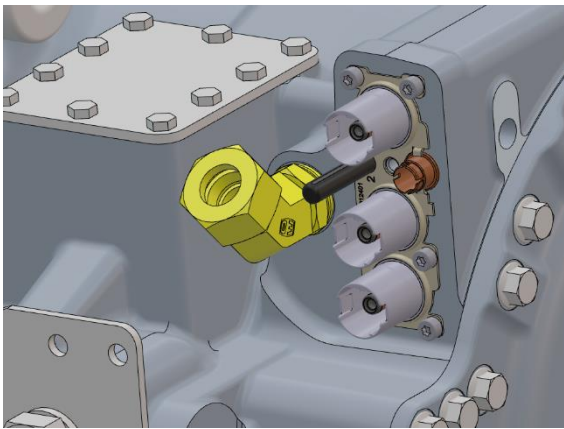

Coolant In

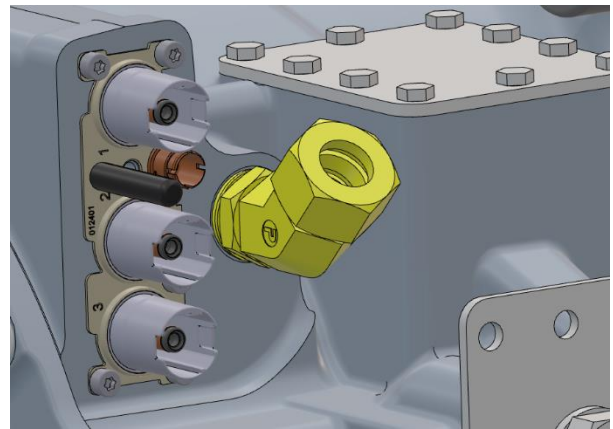

Coolant Out

BATTERIES

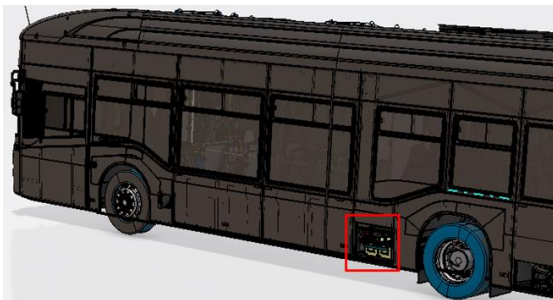

The batteries are located in the left rear part of the vehicle. There are 2 batteries in the vehicle. Each battery is 12V and 105 Ah.

TIRE INFLATOR SET



The vehicle air supply port is accessed through the maintenance cover located in front of the right rear wheel of the vehicle.

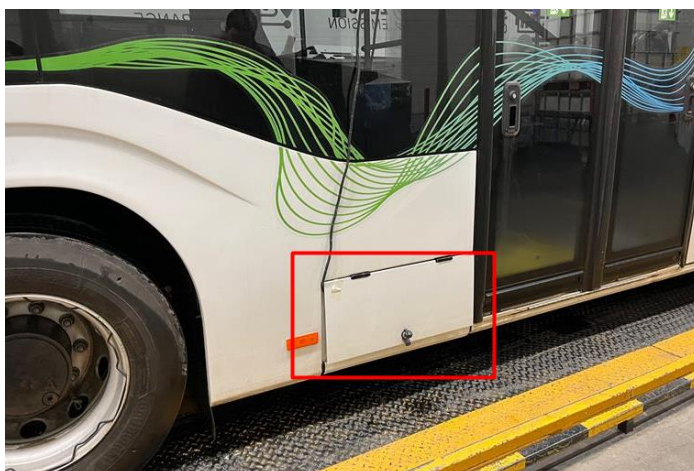

- If the air pressure in the vehicle tires is low, the tire inflation kit between the tool is used to adjust the tire pressure. To do this:
- Park the vehicle in such a way that it does not obstruct the traffic.
- Apply the parking brake, shift the gear to neutral and start the engine. Get the tire inflation kit.
- Connect one end of the hose to the tire valve and the other end to the air outlet. Complete the inflation process by giving gas to the engine.

ELECTRONIC BRAKE SYSTEM (EBS)

EBS (Electronic Brake System) is a system that adds electronic signals to the brake air control system (sent when the brake pedal is pressed) to improve air brake response. EBS maintains the same brake feel regardless of whether the vehicle is loaded and is a device that increases driver operability and safety.

- EBS is not a device to counter unsafe driving practices. Always maintain a safe speed and a safe distance between yourself and other vehicles.
- All tires fitted to the vehicle must be of the specified size, make and tread design (this includes winter tires). Fitting different types of tires on the vehicle is dangerous and may result in reduced braking ability and unstable operation of the vehicle.

EBS Operation Check, Operation, Fault



When the starter switch is turned to the "ON" position, the brake warning lamp comes on before it goes off after about 3 seconds. If the warning light goes out, the EBS is normal. If the warning light does not come on even when the ignition switch is turned to the "ON" position, the bulb may be burnt out or there may be an EBS malfunction.

While the EBS is running, operating noises can be heard from the EBS components. If the brake warning light illuminates or flashes while driving, the EBS, ABS/ASR may be faulty. Please contact your nearest Isuzu Dealer.

NOTE: Even if the EBS is faulty, normal brakes will continue to operate normally. Since the EBS will be inoperable at this time, the brake pedal will have to be pressed

harder than usual to obtain the required braking force.

Driving Precautions for EBS Equipped Vehicles

EBS is not versatile enough to allow driving in conditions that exceed safe limits. Always drive safely.

WARNING!

If the starter switch is turned to the "ON" position (start the engine) on a hill, etc., the EBS may be affected by a drop in battery voltage, causing the vehicle to roll downhill. After pulling the parking brake lever or fully depressing the brake pedal, turn the starter switch to the "ON" position (engine start).

CAUTION!

- Although models with EBS have improved braking response compared to models without EBS, EBS is not a device to prevent unsafe driving practices. Always drive at a safe speed.
- On models with EBS, the EBS is activated when the brake pedal is depressed, regardless of whether the starter switch is set to the "LOCK" position. Even if the starter switch is turned to the "ON" position with the brake pedal depressed, emissions from the EBS device are not vented. (In this case, the EBS system operation check will not be performed.) If exhaust sounds from the EBS system cannot be heard when the brake pedal is depressed and released, the EBS exhaust port may be frozen or blocked by snow or ice that needs to be removed.
- EBS operation may be affected if battery voltage drops. Periodically inspect the battery.
- On models equipped with EBS, the on-board computer detects the loading conditions, making it unnecessary for drivers to adjust how they depress the brake pedal, regardless of whether the vehicle is loaded or unloaded. However, as with vehicles without an EBS system, the braking distance will increase if the brake pedal is not sufficiently depressed when the vehicle is empty.
- If the driver depresses the brake pedal instead of fully depressing the brake pedal, the EBS will not operate at its full capacity. Pumping the brakes will also result in a decrease in brake performance due to the increase in air. ("Pumping the brakes" is defined as the continuous pressing of the brakes at a rate of one or more times per second.)

RECOMMENDATION

- When installing an electronic device such as a radio, pay attention to the installation location and orientation so that the EBS function is not affected. Also, please contact the nearest Isuzu Dealer during installation.

How to Make EBS Work Correctly?

EBS calculates the loading conditions and determines braking power using the amount of brake pedal stroke along with the vehicle deceleration rate. If the loading

conditions change, the EBS recalculates the weight. This recalculation will only be completed after the vehicle has been completely stopped at 30 km/h (19 MPH) or more, a total of 3 to 4 times without pumping the brakes.

CAUTION!

- Lighting of the brake warning light indicates that an EBS fault has occurred. In this case, normal brakes will still work normally, although the feel of the brakes will change significantly due to the operation of the EBS. If the EBS fails, press the brake pedal firmly, stop the vehicle and contact your nearest Isuzu Dealer.

ELECTRONIC STABILITY CONTROL (ESC)

ESC improves safety and vehicle stability. ESC controls the engine power and applies the braking force to the wheels that need it, to prevent wheel spin during starting and accelerating on slippery roads, to protect the traction power, to prevent the vehicle from sliding sideways and to improve vehicle stability.

The ESC has various sensors that detect changes in the vehicle's operating conditions while cruising. The anti-slip regulator (ASR) prevents wheel spin when starting or accelerating. ASR is integrated into ESC. ESC is activated automatically when the vehicle is started. On models with EBS, the ESC OFF switch can be used to disable ESC and ASR. For models without EBS, the ESC OFF switch (if equipped) can be used to disable ESC or ASR only.

CAUTION

- The ESC warning lamp flashes when ESC works.
- The ESC warning lamp also flashes only when the ASR function is working.
- If the ESC warning lamp is flashing, the road surface is slippery or the acceleration is too fast. Depress the accelerator with less force and drive cautiously.
- The ESC warning light may also flash when the accelerator pedal is fully depressed on non-slippery roads such as dry asphalt roads. This is a normal condition that anticipates slipping and implements the command action.
- When driving on snowy or icy roads, wear snow chains or winter tires and drive carefully, even if the vehicle is equipped with ESC. ESC is not equipment that greatly improves vehicle stability when starting or driving, so drive carefully on snowy or icy roads.
- When snow chains are fitted, it may be easier to start the vehicle on an icy or sloping road when only the ASR is disabled. However, be careful as disabling the ASR will cause the vehicle to lose stability.
- Install tires of the specified size, same make, same type and same tread design (including winter tires) on all wheels. Also, do not install or use tires with widely varying degrees of wear. The ESC may not function properly if tires of a different size, type, or degree of wear than specified are used.
- The ESC may not work properly if the tire diameter is different, such as when a chain or spare wheel is fitted.
- ESC may not work properly if suspension, brake or engine related parts are replaced or modified with non-Isuzu genuine parts.
- Be sure to contact your Isuzu dealer for replacement or repair of the steering

wheel or steering-related parts. The steering wheel has a sensor that detects driving conditions, and the ESC may not function properly if the steering wheel center position misalignment.

- Do not tow a vehicle with only the front or rear wheels raised with the ignition switch in the "ON" position. ESC may work and cause crash.

NOTE:

The following situations do not indicate that the ESC is faulty.]

- An electric motor noise may be heard from the engine compartment immediately after starting the engine. Buses originate from the self-control process implemented by the ESC. You may also feel a slight vibration if the brake pedal is depressed during this time.
- Vibration or tightness may be felt in the brake pedal movement while the ESC is operating. In addition, the vehicle body may vibrate or the operating sounds of the system may be heard. This is normal when ESC is running.
- After the vehicle has started, the ESC will not work until it reaches a speed of approximately 15 km/h (9 mph).

ESC OFF Switch

When you try to free the vehicle from mud or soft snow with the ESC and ASR operating, the engine power may not increase even though the accelerator pedal is pressed, and it may be difficult to free the vehicle. In such cases, using the ESC OFF switch makes it easier to recover the vehicle. ESC can be disabled using the ESC OFF switch, or only the ASR function of the ESC system (the anti-skid function during take-off or acceleration) can be disabled.

ASR OFF Indicator Lamp



ESC OFF warning lamp



Cancellation of ASR

When ESC is active after the vehicle is started, press and hold the ESC OFF switch for about 1 second to cancel the ASR function, the ASR OFF indicator lamp on the instrument panel will turn on. Pressing the key again for approx. 1 second reactivates the ASR function.

CAUTION

- When you turn ASR off, its function that assists you when driving on slippery surfaces is now deactivated. Always be careful when driving on slippery roads.
- Always operate the ASR during normal driving.
- Even when ASR is off, partial brake control is active. ESC warning lamp illuminates when operating in fog.

NOTE

- Automatically reactivates when the engine is stopped and restarted while ASR is deactivated.

Cancellation of ESC

When ESC is active after the vehicle is started, press and hold the ESC OFF switch for about 5 seconds to cancel the ESC function, the ESC OFF indicator lamp on the instrument panel will turn on. The ESC function is reactivated when the key is pressed again for approximately 1 second.

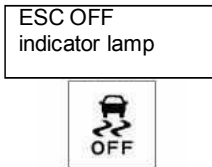

CAUTION

- When you turn off the ESC, its function that assists you when driving on slippery surfaces is now disabled. Always be careful when driving on slippery roads.
- Always operate the ESC while driving under normal conditions.
- Be careful when driving on slippery roads, as ASR is turned off when ESC is turned off.

NOTE:

When the engine is stopped and restarted while ESC is disabled, ECS is automatically reactivated.

ESC Operation Control and Operation and Fault Conditions of ESC

ESC Operation Control

On models equipped with the ESC OFF switch, when the ignition switch is turned to the "ON" position, the ESC warning lamp, ASR OFF indicator lamp (models without EBS), and ESC OFF indicator lamp come on for about 3 seconds and then turn off.

For models without the ESCOFF switch, the ESC warning lamp illuminates for 3 seconds and then turns off. If the warning and indicator lights go out, the ESC is normal.

ESC Working

ESC warning lamp flashes while ESC is running.

ESC Faulty

The following states of the ESC warning lamp mean that the ESC may be faulty. Please contact the nearest Isuzu authorized service.

- ESC warning lamp comes on while driving.
- On models equipped with the ESC OFF switch, the ASR OFF indicator lamp (models without EBS) and the ESC OFF indicator lamp come on while driving (even if the ESC OFF switch is not pressed).
- On models equipped with the ESC OFF switch, the ESC warning lamp, ASR (ESP/ESC) OFF indicator lamp (models without EBS) and ESC OFF indicator lamp do not come on when the ignition switch is turned to the "ON" position.

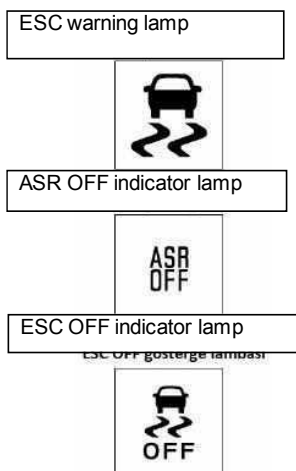

- On models without ESC OFF switch, the ESC warning lamp does not come on when the ignition switch is turned to the "ON" position.

Driving Warnings for Vehicles with ESC

CAUTION

- The ESC is not a device that ensures that the vehicle can be used under conditions that exceed the limits of safe use. Always drive carefully.
- Always focus on safe driving and rely on the ESC-equipped vehicle with vigilance, don't drive too fast and don't turn the steering wheel too fast.
- ESC does not increase the grip of the tires, but unlike vehicles without ESC, it keeps the vehicle's slipping and skidding movements under control during take-off and acceleration on slippery surfaces and improves vehicle stability. On roads that become slippery due to icing, etc., tires fall out of grip, steering control weakens and the vehicle becomes unstable. Always drive at a safe speed perfectly suited to road surface conditions and the condition of the tyres, and avoid accelerating.
- ESC is a system for maintaining traction and vehicle stability. Operate this system even when not needed. When the system is turned off, drive the vehicle with caution and at a safe speed perfectly suited to road surface conditions.
- Even if the vehicle is ESC equipped, avoid depressing the accelerator and clutch (manual transmission models) pedals rapidly and avoid sudden steering movements. Especially when starting off on slippery roads, start the vehicle slowly, as in vehicles without ESC.
- The ESC warning lamp flashes when ESC works.
- The ESC warning lamp also flashes only when the ASR function is working.
- If the ESC warning light is flashing, the road surface is slippery or the acceleration is too fast. Depress the accelerator pedal with less force and drive cautiously.
- The ESC warning lamp may also flash when the accelerator pedal is fully depressed on non-slippery roads such as dry asphalt roads. This is a normal condition that anticipates slipping and implements the command action.
- When driving on snowy or icy roads, wear snow chains or winter tires and drive carefully, even if the vehicle is equipped with ESC.
- When snow chains are fitted, it may be easier to start the vehicle on an icy or sloping road when only the ASR is cancelled. However, be careful as disabling the ASR will cause the vehicle to lose stability.
- Do not install an ordinary commercially available limited slip differential (LSD) on the vehicle. ESC may not work properly

NOTE

- Vibration or tightness may be felt in the brake pedal movement while the ESC is operating. In addition, the vehicle body may vibrate or the operating sounds of the system may be heard. This is normal when ESC is running.
- Suspension, tires, brakes etc. The ESC-Warning lamp may illuminate if there is significant wear or deterioration in related parts. In such cases, ESC may not work properly.

- The ESC warning lamp may come on when the vehicle is on the turntable at a parking space entrance or any moving object, etc. In such cases, restart the engine after leaving the platform.
- The ESC warning lamp may come on while driving on extremely sloping roads (such as acceleration gradients on racetracks, etc.). Do not drive on such roads as the ESC will not function properly in such cases.
- The ESC warning lamp may come on when the battery cables are disconnected or the battery voltage is low. While the ESC warning lamp is on, the ESC function will turn off, but after the vehicle has been driven normally for a while, the ESC warning lamp will turn off, then the ESC function will continue. If the ESC warning lamp remains on even after driving the vehicle for a while, contact the nearest Isuzu authorized service.

Angular Speed Sensor

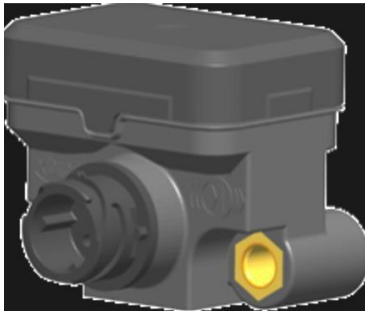

The speed sensor is located under the vehicle floor behind the front axle, close to the vehicle's center of gravity.

Axial deviation in the vehicle is detected as instantaneous angular acceleration and transmitted to the brake system control unit in the form of an electronic signal. In a critical situation, how much the vehicle deviates from the route is checked. It provides information on how to activate the stability control functions.

Steering Angle Sensor



The angle sensor, which passes through the steering column, is located under the signal group. It transmits the maneuver request from the driver to the brake system control unit according to the amount of steering wheel rotation. The transmitted information is sent as an electronic signal. Calibration is performed when the system is first installed to match the signal from the sensor with the vehicle's turning angle

The ESC system will be faulty if the steering wheel is pre-aligned and installed, replaced or renewed. In these cases, the installation should be done in authorized services.

ELECTRONIC BRAKE FORCE DISTRIBUTION (EBD)

EBD is a function that uses ABS to optimally distribute the braking force between the front and rear wheels to compensate for changes in load conditions or load shifts due to acceleration or deceleration, thus preventing the rear wheels from locking up.

CAUTION

- In case of a problem with the EBD function, the ABS warning lamp and the brake warning lamp come on at the same time.
- If there is a problem with the EBD function, the rear wheels will lock more easily. At the first opportunity, go to the nearest Isuzu authorized service and ensure that the control and maintenance is carried out.

NOTE

- When the EBD is operating, the brake pedal may kick back slightly or you may hear a sound similar to the one you hear when ABS is operating. None of these situations indicate an abnormal situation.

ACOUSTIC VEHICLE ALERT SYSTEM (AVAS)



Audible warning system for vehicles with silent engines for PEV (pure electric vehicle), HEV (hybrid electric vehicle) and FCV (fuel cell vehicles).

- Simple engine sound
- Space-saving and compact sensor
- Lightweight single box system
- Low power consumption

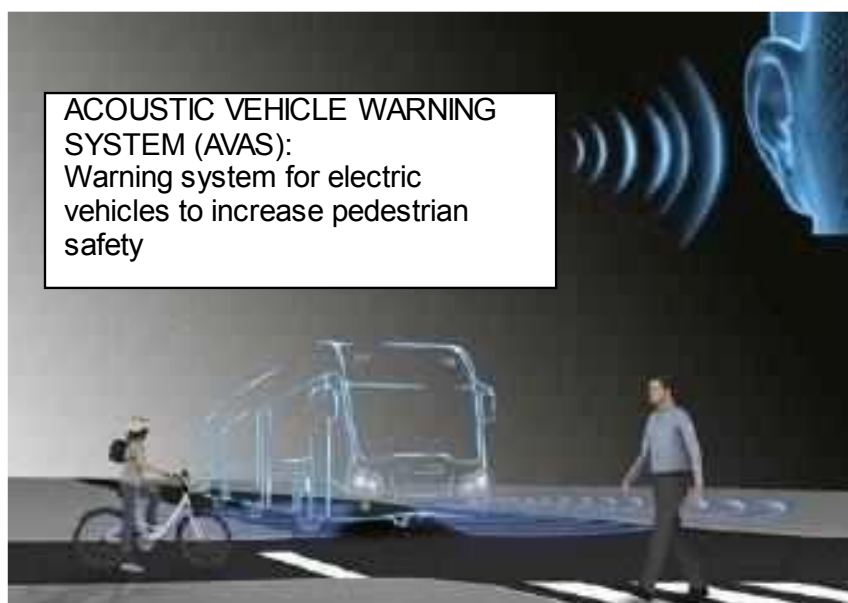

REGENERATIVE BRAKING

Regenerative braking system that acts as a retarder charges the battery at no additional cost, increasing vehicle range..

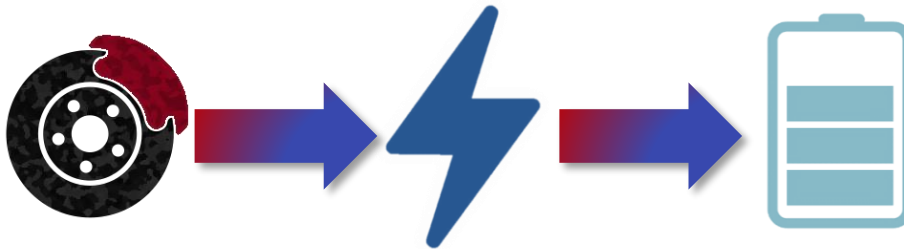

More efficiency, more range

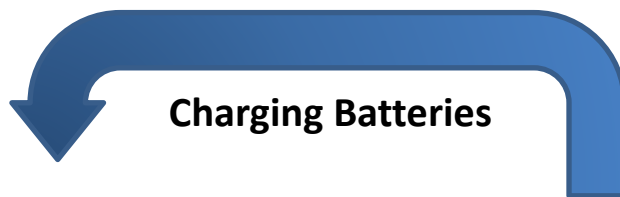

ENGINE ROOM FIRE DETECTION SYSTEM

When the fire detection system detects a temperature above 120 degrees in the engine room, it gives a warning with a Red light 🔴 and an alarm on the warning panel.

ENGINE COMPARTMENT FIRE DETECTION AND AUTOMATIC FIRE SUPPRESSION SYSTEM (FIREDECT-OPTIONAL-1)

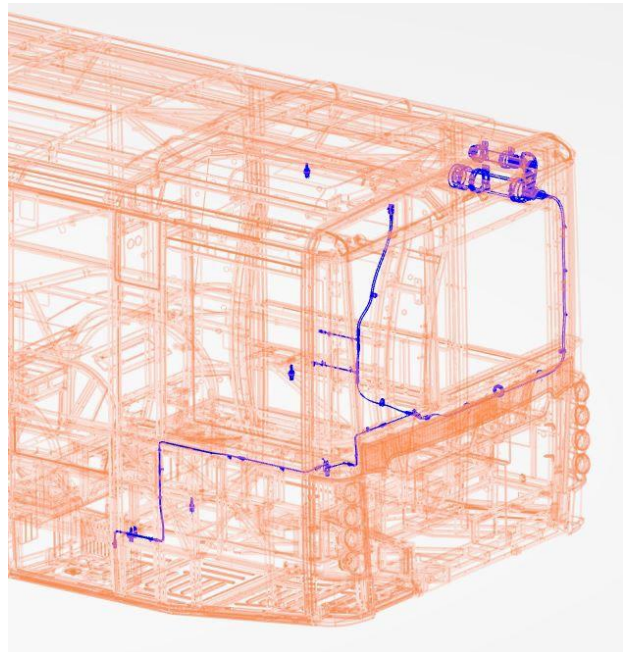
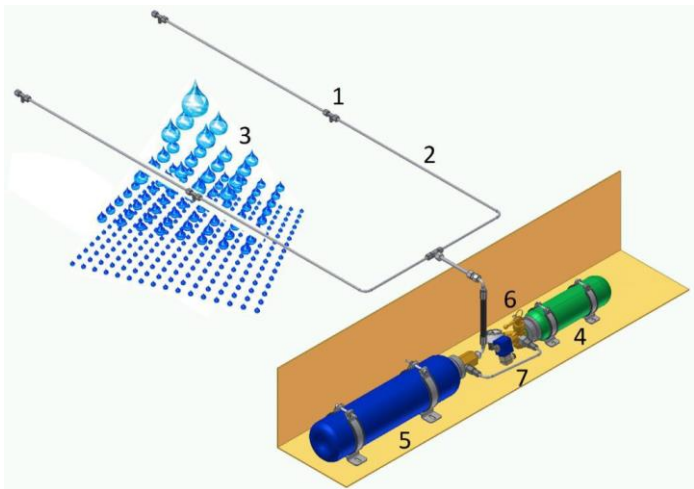

No	Name
1	High pressure (20MPascal/200bar) water mist nozzle
2	High-pressure stainless-steel pipe system
3	Extinguishing Agent (Temper S-30) as 50 μ droplets
4	Nitrogen pressure bottle
5	Temper S-30 Water + agent bottle
6	Mechanical pressure valve for manual actuation (optional / not all models)
7	Electric pressure valve (coil and solenoid valve), pressure gauge (optional)

This is a system which consists of a pressure fire detection hose and fire spout nozzles which pass from the areas where a fire may occur in the engine room. There are 2 tanks in the system, one is the nitrogen tank which provides the detection of fire, and the other one is the fighting tank in which there was fireextinguishing fluid. Illuminated and audible lights alert during the fire detection.

Fire suppression system uses water as the extinguishing agent. The water is atomized at a high pressure of at least 160 bars at the nozzles. The pressure energy is used to split the water into small droplets of 50 μ with an extremely large surface area for cooling and provides these droplets with sufficient kinetic energy to bring them rapidly to the protected area. During fire extinguishing, the fire extinguisher is sprayed from nozzles which reduce the temperature, cut contact with air and convert them to columnar smoke clouds. The fire extinguisher is mainly antifreeze water based. Extinguishing time is between 3 - 5 seconds at normal but the effective time is 50 - 75 seconds.

WARNING

In case of fire;

- Stop the engine.
- Empty the vehicle.
- Turn off the current.
- Keep the bonnet closed at least 5 minutes.
- Use a portable fire extinguisher if needed.
- Connect with the authorized Isuzu Dealer.

WARNING

The following operations should be performed when the fire extinguishing system activated because of a reason other than fire and the tanks emptied:

- Wash all component surfaces with water in order for the parts in the engine room effected by the system not to corrode.
- Wash inside of the pipes and nozzles by giving water to the fire extinguishing piping system, but if it was too late for this, remove the nozzles and clean nozzles and pipes with water. Replace the nozzles if required.
- Insert protection covers to nozzles again.
- Activate the system again by mounting filled tanks.

FIRE DETECTION THE CONTROL UNIT

It integrates the control unit and the display / HMI in one single device only.

No.	Name
1	Fire Button
2	Action Button
3	Green Led
4	Yellow Led
5	Red Zone Led

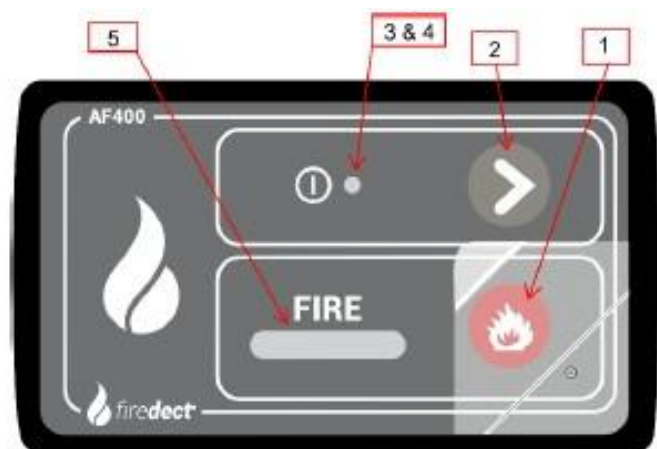

Fire Button

WARNING

- Press only in emergency.

Press the fire button to activate immediately the suppression system manually.

CAUTION

- The fire button is protected by a plastic cap which has to be replaced every time the fire button is actuated.

Action Button

Normal operational mode:

- Short press has no functionality.
- Long press will start the LED & Alarm self-test.

Warning/diagnosis mode:

- Short press
First press will silence/mute the warning signal.
Every further press will show you the "Fault Display" (blink codes). If there is at least one error.
- Long press will reset the warnings. (The resets will only be reset if you are in the "Fault Display").

Alarm mode:

- Short press will delay the activation by 15 seconds.
- Long press will silence/mute the alarm

Green Led

Blinking:

- The control unit is booting.

Blinking slowly:

- The control unit is in the emergency current mode.

Constantly:

- The control unit is on normal operational mode.

Yellow Led

Warning/Diagnosis mode:

- Blinking
There was a warning, but it has not yet been queried.
- Constantly
There is currently a warning.

Red Zone Led

Fire in zone X detected. The suppression system is automatically activated.

- Blinking
Alarm countdown for activation.
- Constantly
Alarm activated.

Starting The Control Unit

When the control unit is connected to the power source, the green led will flash for 20 seconds, showing that the control unit is in boot loader. After leaving the boot loader, all leds will flash for 2 seconds and the buzzer will also become audible. The control unit will then go into operational mode recognizable by the glowing green led. If any of the monitored zones is not operational when the control unit is booted, the yellow alert led and zone led will flash and the buzzer will sound. In this event, the suppression system will not be activated. The zone can be checked, and if operational, the alerts will reset to normal state.

Normal Operational Mode

In normal operational mode, the control unit will monitor all three (3) zones for fire. A long press of the action button while the control unit is in normal operational mode will cause the buzzer to sound and all leds will light up.

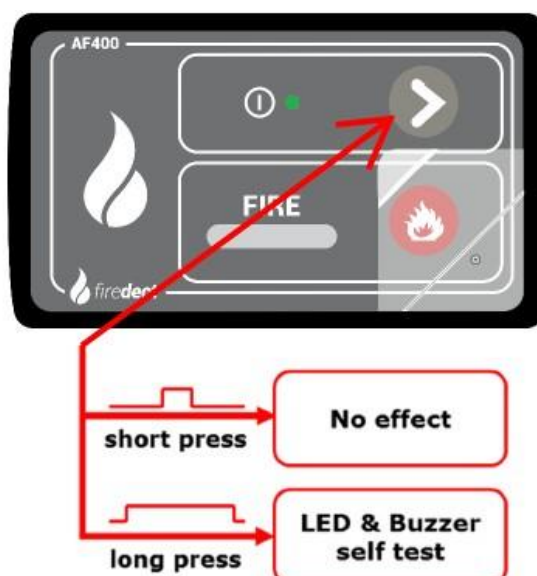

Alarm Mode

If a fire is detected in any of the zones, the zone led will start to flash and the buzzer will sound. The flashing and beeping will continue to get faster until the suppression system is activated.

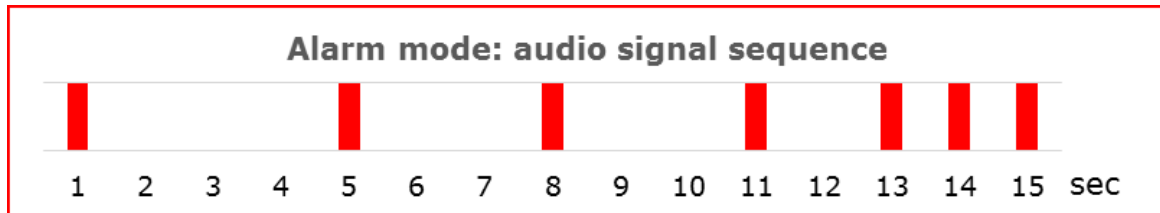

If the suppression system is active the led will flash constantly as well as the buzzer beeps constantly. There is a 15 second delay on activation, and the system is activated for 3 seconds. The alarm can be muted by pressing the action button for 0.8 seconds. Pressing the action button for less than 0.8 seconds will reset the delay in activation to 15 seconds. If a fire is detected in another zone, the timer will not be reset to 15 seconds. After the initial delay, the suppression system in Zone 1 will be activated for 3 seconds, followed by Zone 2 for 3 seconds. If the fire button is pressed, the suppression system for the zones will be activated for 3 seconds one after another.

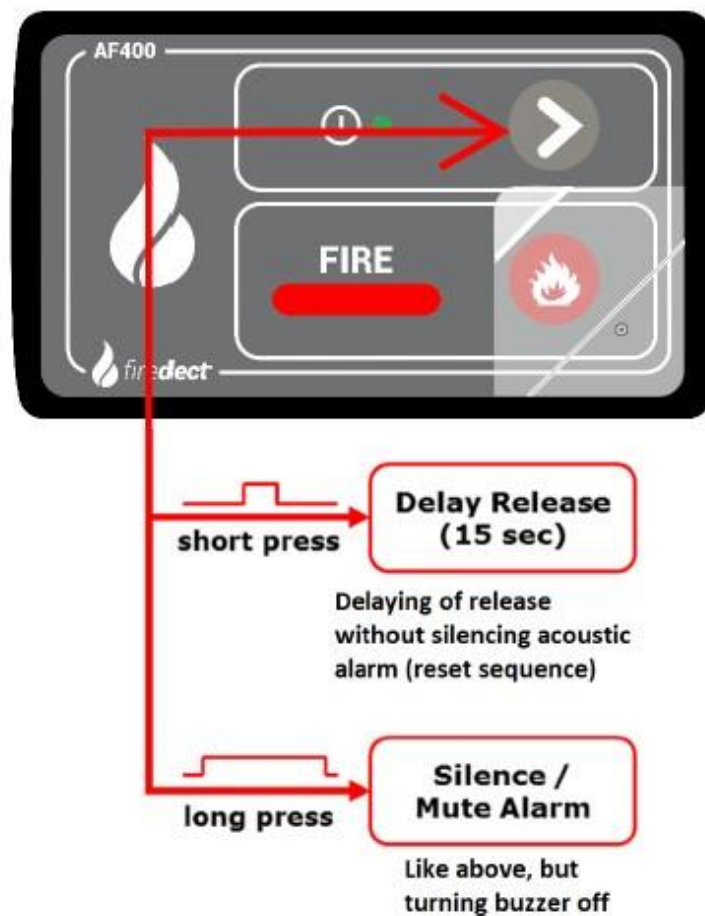

Warning / Diagnosis Mode

If any warning occurs, the yellow led will flash and the alarm will beep 3 times every 5 seconds (in the emergency current mode: 3 times every 10 seconds).



A short press on the action button will silence/mute the acoustic warning signal. Every further press of the action button for less than 0.8 seconds will cause the control interface to show an error codes this will not work in alarm mode. A long press on the action button while showing the error codes will reset all error codes.

#	Error - operational	Z1	Z2	Z3
1	Fire-Sensor/Terminating - Resistor -> bad value	0	1	0
2	Low-Pressure	0	2	0
3	Defect in Valve-Connection	0	3	0
4	Low Battery-Voltage	0	4	0
#	Error - boot	Z1	Z2	Z3
1	Fire-Sensor/Terminating - Resistor -> bad value/not connected	On	Off	Off
2	Low-Pressure/not connected	Off	On	Off
3	Defect in Valve-Connection	Off	Off	On
4	Fire Alarm	On	On	On
5	Wrong Battery	Off	Off	Off

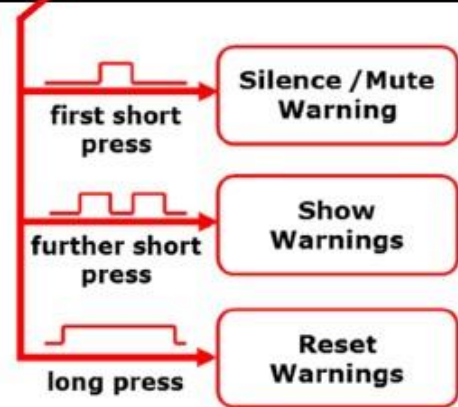

ENGINE ROOM FIRE DETECTION SYSTEM AND CONTROL UNIT (FOGMAKER-OPTIONAL-2)

Control Module

In Case Of Alarm - Fire

Red motor fire symbol/red lamp flashes red.

Alarm siren gives repeating acoustic signal.

Fire alarm signal – bus manufacturer’s system:

See bus manufacturer’s manual.

Do not start the vehicle until the cause of the fire has been established and rectified!

Clean up the engine compartment as soon as possible to prevent corrosion on metal parts and unwanted flash-overs in the electrical system. Hose down with water, preferably at high-pressure. Alkaline washing agents can be used. See also the manufacturer’s recommendations for washing the engine compartment.

Engine wash after fire

Low pressure signal with fogmaker bus alarm:

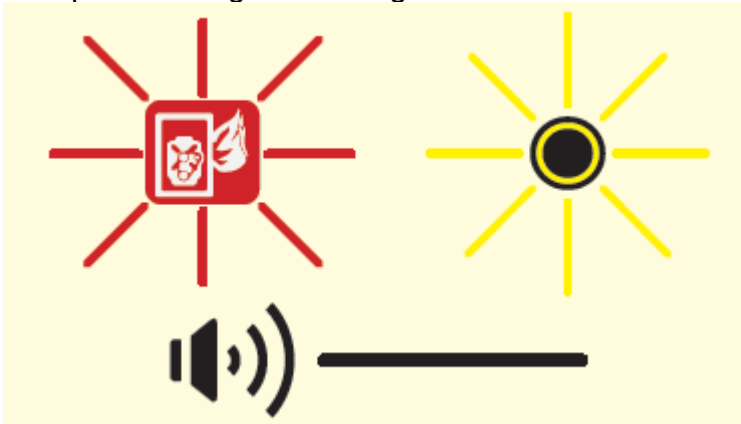

- Red engine fire symbol/yellow lamp lights constantly
- Alarm siren sounds constantly.
- Low pressure signal- bus manufacturer’s system:
- See bus manufacturer’s manual.
- Contact the nearest authorized service.

In Case Of Alarm – Fire

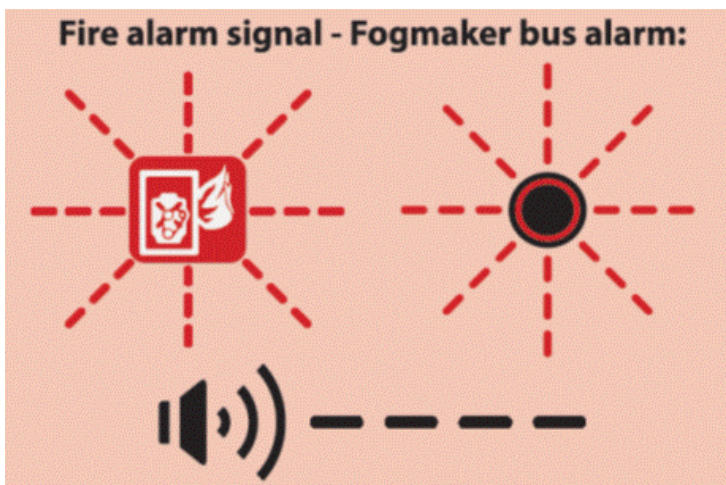

Overview, Fogmaker's Fire Protection System

This bus fitted with a fully automatic fire protection system for the engine compartment

The system comprises:

- Piston accumulator (1)
- Detector bottle (2)
- Pipe system with nozzles (3)
- Detector tube (4)
- Fogmaker bus alarm with acoustic and light signals or alternatively manufacturer-specific alarm panel (5)

NB! The system may vary in different buses.

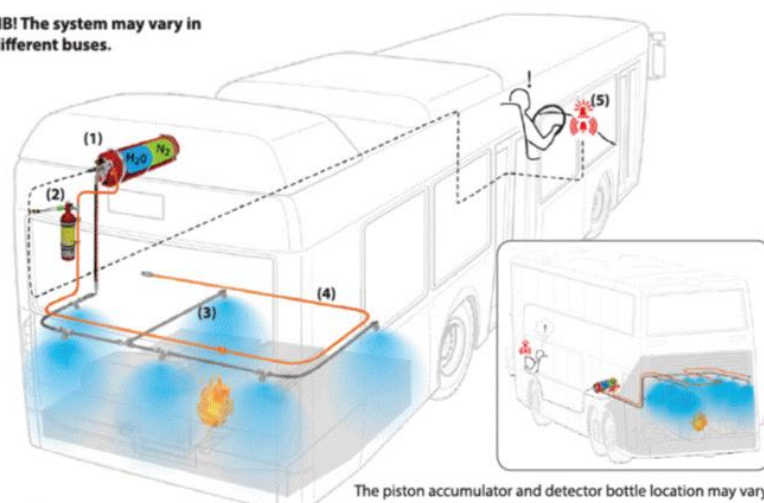

Routine Maintenance

Pressure switch installed: Check that lamps indicating low pressure are not alight on the bus alarm button.

Pressure switch not installed: Make sure the pressure in the piston accumulator is within the green zone on the pressure gauge.

Test the alarm before starting the day's work..

Alarm test with the Fogmaker bus alarm:

- Press down the button- two variants, see below:
- Check that there are both a sound and light signal.



Alarm test – bus manufacturer's system:

See bus manufacturer's manual.

Quick-guide for piston accumulator and detector bottle

Piston accumulator: 100-105 bar at 20°C

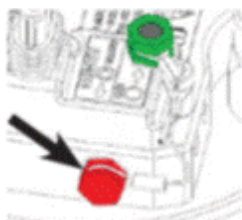

Red safety screw
mounted in the side of the valve **isolates the system**
- done before all handling

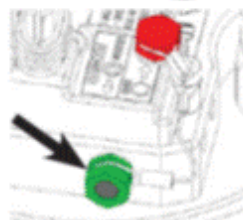

Green screw mounted
in the side of the valve **unlocks the system** so
it can deploy

Detector bottle: 20-24 bar at 20°C



The detection system is **isolated**
by **closing the ball valve:**

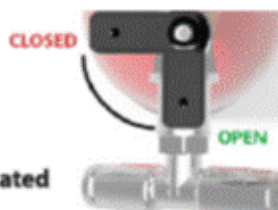

5. SERVICE AND MAINTENANCE

CLEANING THE VEHICLE

Exterior Cleaning

- Do not clean your vehicle with detergents and chemicals, do not wipe with gasoline.
- Use pressurized water for vehicle cleaning (except the engine compartment), make sure that there is no water on the vehicle after cleaning, remove excess water with a cloth or chamois.
- Do not wash your vehicle under direct sunlight.
- Keep the inner parts of the mudguards clean in winter.
- Use only soap and water when cleaning the air bellows.
- There are components operating with high voltage at the rear of the vehicle. Never use water for cleaning this part. There are battery packs in the upper part of the vehicle. Do not open the protection cover on the battery packs except for the technical service.



Internal Cleaning

- Clean the instrument panel with a wet cloth, do not use substances such as alcohol or thinner.
- Clean the seats with a wet cloth or foamed vinylex cleaner.
- Wipe the passenger floor with a wet mop and then dry it.

COOLING SYSTEM AND ANTIFREEZE FILLING

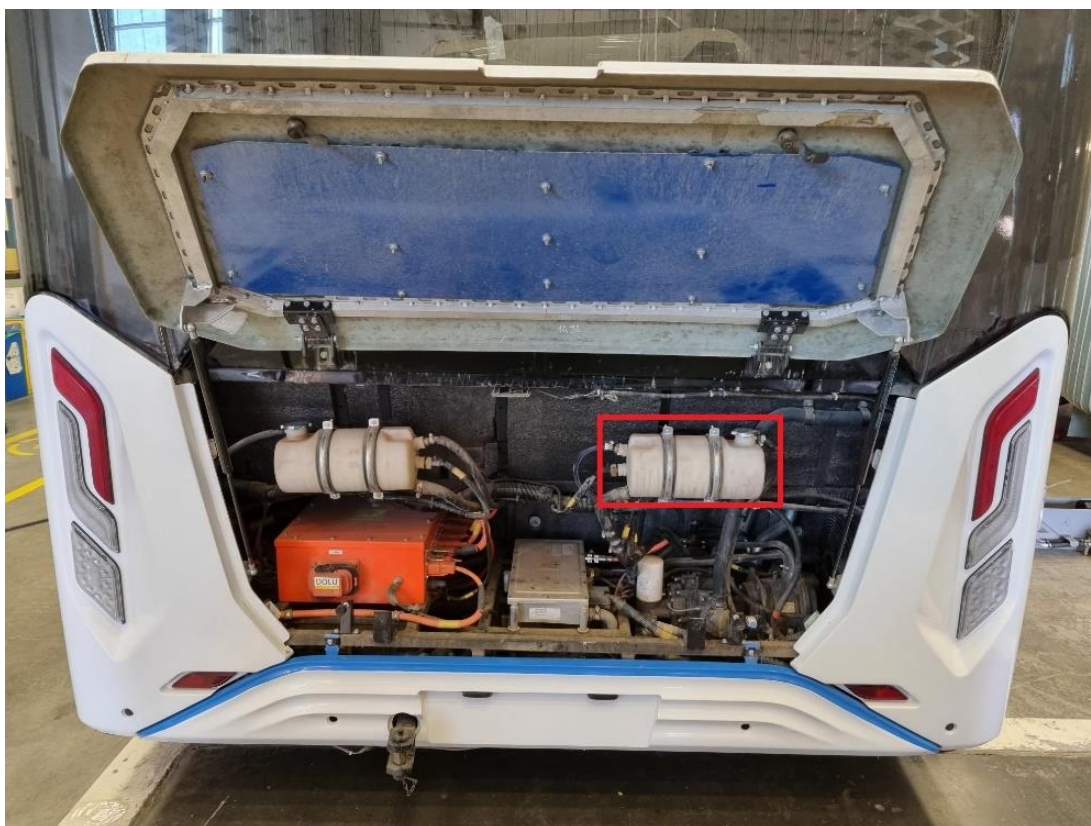

The cooling system keeps the electric motor driven axle, inverter, DC/DC converter and air compressor components within the optimum temperature range so that these components can be operated efficiently and malfunctions that may occur due to excessive temperature may be prevented. The coolant used in the cooling system is a mixture of 50% water and 50% glycol. The freezing point of this mixture is below -38°C , the boiling point is minimum $+108^{\circ}\text{C}$. No additives should be added to the coolant.

1. Park the vehicle on a flat area.
2. Open the cover of the expansion tank located on the right side of the engine room.
3. Start filling the expansion tank with GLYSANTINE G48 (Blue) engine coolant with a 50/50 antifreeze-water mixture.
4. When the expansion tank is full, stop filling. Wait 1-2 minutes to allow the air entering the system to discharge naturally and the coolant level to stabilize. Then add water to the tank again.
5. Start the cooling line pump from the cluster.
6. Continue to add antifreeze to the expansion tank as the level in the expansion tank decreases.
7. Expansion tank max. After it is fixed at the level, close the expansion tank cover.
8. Stop the cooling system pump from the cluster.

HEATING AND AIR CONDITIONING SYSTEM LINE FILLING AND AIR BLEEDING OPERATIONS



1. Open the engine room cover and front cover of the vehicle.
2. Open the air vent covers of the floor heaters located in the passenger middle compartment.
3. Open the expansion tank cover on the left side of the engine room.
4. Fill the expansion tank with GLYSANTINE G48 (Blue) engine coolant with 50/50 glycol-water mixture or an equivalent coolant up to the max level of the tank.
5. Stop filling when the expansion tank reaches its maximum level.
6. Wait 1-2 minutes to allow the air entering the system to discharge naturally and the coolant level to stabilize.
7. When the expansion tank is fixed to the max level, close the expansion tank cover.
8. Start the vehicle.
9. From button 3 of the HVAC control panel, Frontbox will increase the fan speed to the maximum level. Move button 4 to the red maximum position. This will ensure maximum opening of the valve that controls the flow of antifreeze going to the Frontbox at the front of the vehicle and will operate the 2 pumps in the heating system and the heater on the vehicle will start to operate. (NOTE: The additional water pump in the left front wheel area of the vehicle starts 20s later than the water pump in the heater area. If the frontbox fan speed is 0, the driver valve will not open.)
10. As the pumps operate, the level of the heating expansion tank will decrease. Open the tank cover and add antifreeze to the maximum level of the tank.
11. Take the air from the relevant heating units by loosening the air vent of the heater located in the middle part of the passenger. Continue to bleed the air from the heating unit until a bubble-free and continuous (uninterrupted) flow is observed from the transparent hose inside the unit.
12. While air is being taken from the heating units, the antifreeze level in the expansion tank will decrease. Continue to add antifreeze to the heating expansion tank until the maximum level of the tank is filled during the deaeration process.
13. To get air from the heater core of the Frontbox unit, press a pointed tool on the heater vent of the unit or connect a manometer hose to the vent. Keep taking air from the vent until you get a bubble-free, continuous (non-stop) flow.
14. While air is being taken from the heating units, the antifreeze level in the expansion tank will decrease. Keep adding antifreeze to the heating expansion tank during the air-bleeding process until the tank's max level is filled.
15. After the heating expansion tank is fixed at the maximum level for 1-2 minutes, close the expansion tank cover.
16. Turn off the vehicle's control panel from the HVAC control panel or turn off the ignition.
17. Close the heater vent caps and trim caps that are opened for air intake.

BATTERY COOLING SYSTEM ANTIFREEZE REFILL

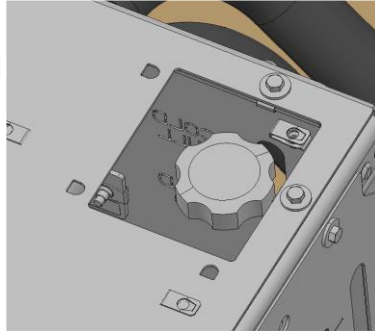
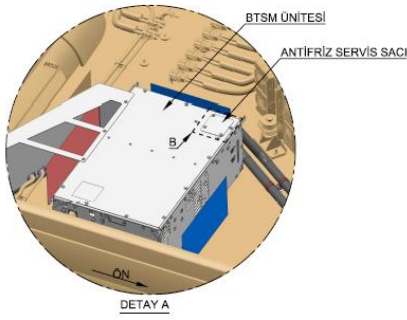

1. Remove the antifreeze service plate of the BTSM unit in detail A.
 2. Open the expansion tank cover.
 3. Fill the expansion tank with GLYSANTINE G48 (Blue) engine coolant with 50/50 glycol -water mixture or an equivalent coolant up to the max level of the tank. Stop filling when the expansion tank reaches its maximum level.
 4. Wait 1-2 minutes to allow the air entering the system to discharge naturally and the coolant level to stabilize.
 5. Then, when the tank is fixed to the max level, close the expansion tank cover.
 6. Follow the steps below for the water pump in the BTMS unit to operate at 100% power.
 - a) Turn on the ignition.
 - b) Activate the emergency button.
 - c) Set the headlights to auto.
 - d) Open the quads.
 - e) Pull the selector for 10 seconds.
- NOTE: If the expansion tank antifreeze level is at or below the minimum level, the BTMS system will not operate to protect itself. Make sure that the antifreeze level is not critical to operate the system while topping up antifreeze at the first filling.
7. As the water pump runs, the level of the expansion tank will decrease. Open the cover of the expansion tank and continue to add antifreeze up to the max level of the BTMS expansion tank.
 8. When the expansion tank is fixed to the max level, close the expansion tank cover.
 9. Turn off the vehicle ignition.
 10. Install the antifreeze service plate.

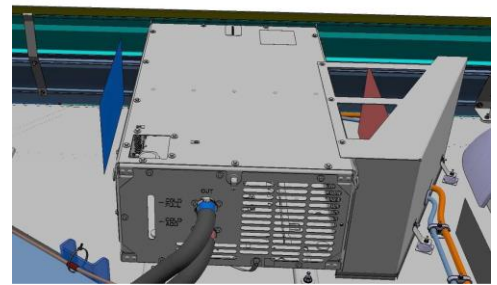
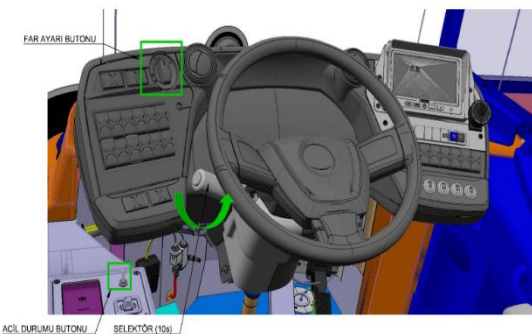

TOWING THE VEHICLE

Removing the planetary gears and towing the vehicle away

This section shows how to separate the drivetrain at the wheel head. The figures show a disassembled electric motor. The activities to be done are the same.

Special Teams:

Z type screwdriver

Danger :

Danger to life due to electric shock in case of contact with energized parts.

Death or severe injury probable.

- Deenergize machine.
- Prevent the device from being switched on again.
- Verify voltage free condition.

1. Lift the vehicle.
2. Loosen the wheel nuts and remove the wheels.
3. Clean the wheel head in the area of the planet carrier.
4. Drain oil (refer to section Changing oil (planetary drive), page 86).
5. Loosen cap screws.



40_080106_01

6. Use two Z-type screwdrivers to press and remove the planet carrier



40_080107_01

7. Remove retaining rings.

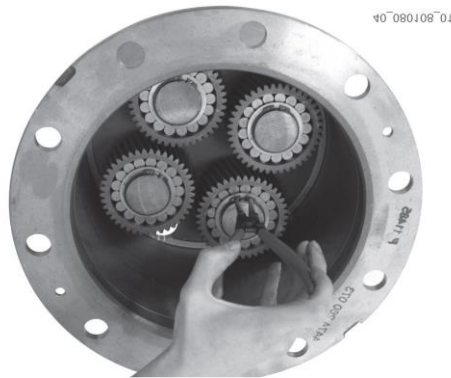

8. Pull off planetary gears with two-armed extractor.

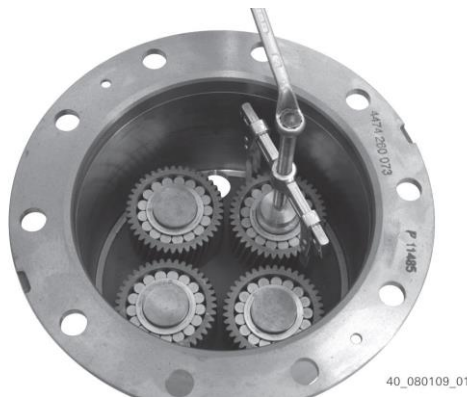

9. Grease and insert O-ring (1).

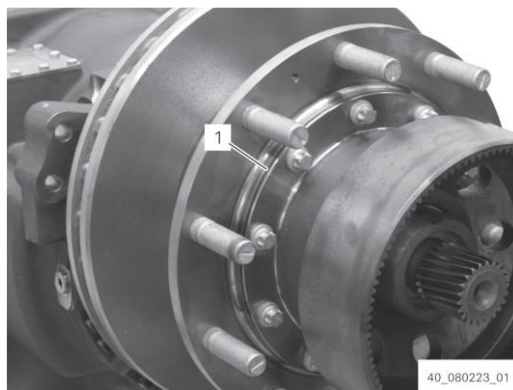

10. Use lifting equipment to raise the planet carrier.

11. Rotate hub, until threaded holes of the hub are in alignment with the holes on the planetary carrier.

12. Slide on planetary carrier until contact is obtained.

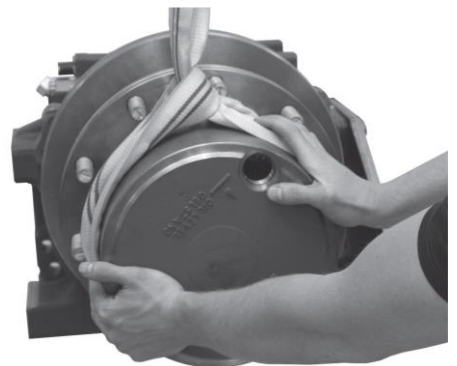

40_080224_01

13. Bolt in and tighten cap screws. Tightening torque: **23 Nm**



14. Push on the wheels.

15. Tighten the wheel nuts according to the specifications of the vehicle manufacturer.

16. Lower the vehicle.

Towing a vehicle without mechanical damage of the axle

For details, please consult the Operating Instructions of the vehicle manufacturer.

Without cooling the axle, tow the vehicle with max. 60 km/h. There is no time limitation.

If the vehicle has an electric motor, it can be driven slowly and carefully for short distances. However, this implies that only a high-voltage expert shall be permitted to disconnect the defective wheel drive from the power supply. An articulated bus with two drive axles is driven accordingly with three wheel drives.

Water contamination of the axle due to external influences

Possible damage to axle due to penetrating water.

- If water is suspected in the axle, check oil.

The use of high-pressure cleaners or steam jets on damaged or worn seals can be a reason for penetration of water.

If water has been detected in the axle, carry out the following activities:

- Dismantle, clean and reassemble the compact bearing
- Change oil.

Checking leak tightness of the electric motors

Requirements:

1. Loosen screw plug (1).
2. Use a measuring cup to collect the fluid.
Balance the found quantity with the above mentioned indications.
If there is cooling water in the motor housing (1), the electric motor must be completely repaired.
If no fluid can be found in the motor housing, further action is not required.
3. Let electric motor cool down.
4. Renew O-ring on the screw plug (1).
5. Turn in screw plug (1) and tighten.
Tightening torque: 35 Nm

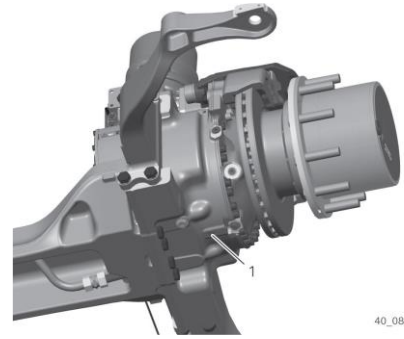

40_080012_01

If there was at least 50 ml of oil in the motor housing, check the oil level in the portal stage and the planetary gear.

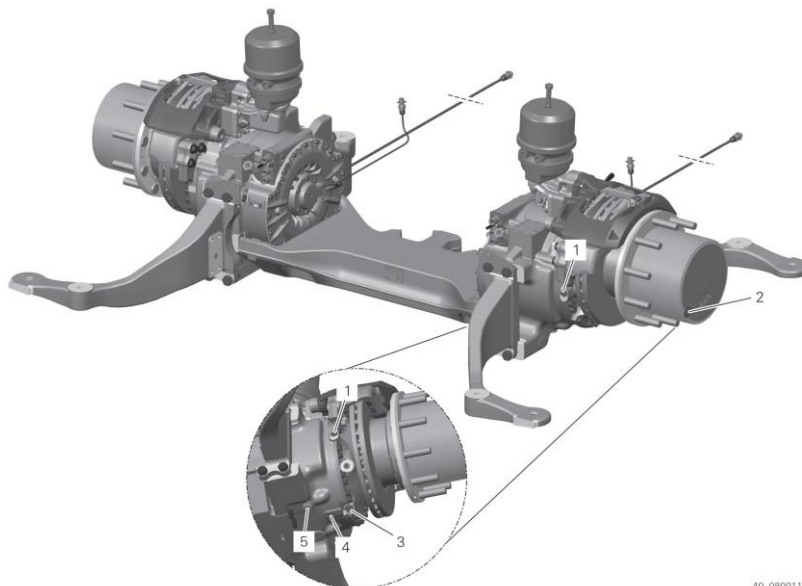

40_080011_01

1. Screw plug oil level and oil fill (portal stage)
2. Screw plug oil drain/oil level/oil fill (planetary drive)
3. Screw plug oil drain (portal stage)
4. Screw plug in motor housing (control bore for tightness)
5. Screw plug for coolant circuit

Note: The axle has two oil circuits per output side.

Checking oil level (portal stage)

- At least once a year (if the oil change interval is longer than 1 year)
- When putting the vehicle into operation
- In case of new or repaired axles

Requirements:

- Axle is installed horizontally into the vehicle.

- Vehicle is in horizontal position in all directions.
- The air pressure in all tires must comply with the vehicle manufacturer's specified value.
- The axle is cold.

Risk of burns due to contact with hot oil.

Slight or moderate injury possible.

- Wear protective goggles.
- Wear protective gloves.

1. Thoroughly clean the screw plug oil level and oil fill (portal stage) (1).
2. Place a suitable container under the screw plug oil level and oil fill (portal stage) (1).
3. Slowly loosen and remove the screw plug for the oil level and oil fill (portal stage) (1).
4. Check the oil level. The oil level must correspond to the bottom edge of the oil level check hole.
If the oil level is not correct, fill or drain oil accordingly. Further information (refer to section Changing oil (portal stage), page 85).
5. Renew O-ring on the screw plug oil level and oil fill (portal stage) (1).
6. Screw in and tighten the screw plug oil level and oil fill (portal stage) (1).
Tightening torque: **50 Nm**

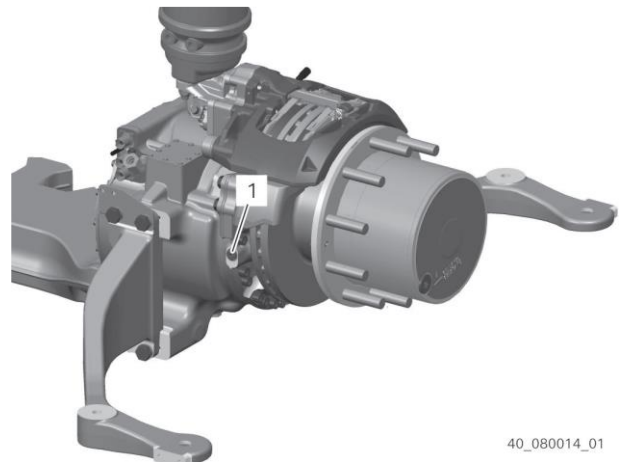

40_080014_01

Checking oil level (planetary drive)

- At least once a year (if the oil change interval is longer than 1 year)
- When putting the vehicle into operation
- In case of new or repaired axles

Requirements:

- Axle is installed horizontally into the vehicle.
- Vehicle is in horizontal position in all directions.
- The air pressure in all tires must comply with the vehicle manufacturer's specified value.
- The axle is cold.

Risk of burns due to contact with hot oil.

Slight or moderate injury possible.

- Wear protective goggles.
- Wear protective gloves.

1. Rotate planetary drive so that the screw plug oil drain/oil level/oil fill (planetary drive) (1) is on top ("12 o'clock position").
2. Thoroughly clean the screw plug oil drain/oil level/oil fill (planetary drive) (1).
3. Place a suitable container under the screw plug oil drain/oil level/oil fill (planetary drive) (1).
4. Slowly loosen and remove the screw plug oil drain/oil level/oil fill (planetary drive) (1).
5. Turn planetary drive to the left, until the reference line is in a horizontal position next to the hole (1).

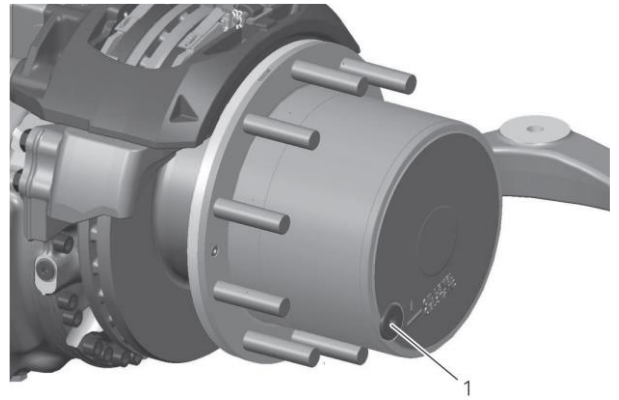

40_080057_01

6. Check the oil level. The oil level must correspond to the bottom edge of the oil level check hole.

If the oil level is not correct, fill or drain oil accordingly. Further information (refer to section Changing oil (planetary drive), page 86).

7. Renew O-ring of the screw plug oil drain/oil level/oil fill (planetary drive) (1).
8. Screw in and tighten screw plug oil drain /oil level/oil fill (planetary drive) (1).

Tightening torque: **150 Nm**

Grease Change (portal stage)

Requirements:

- The axle is installed into the vehicle horizontally.
- Vehicle is in horizontal position in all directions.

Risk of burns due to contact with hot oil.

Slight or moderate injury possible.

- Wear protective goggles.
- Wear protective gloves.

1. Thoroughly clean the screw plug oil level and oil fill (portal stage) (1) and screw plug oil drain (portal stage) (2).
2. Place a suitable container under the screw plug oil drain (portal stage) (2).
3. Slowly loosen and remove the screw plug for the oil level and oil fill (portal stage) (1).
4. Remove screw plug oil drain (portal stage) (2) and O-ring.
5. Completely drain oil into the containers.
6. Let axle cool down to ambient temperature.
7. Renew O-rings on all screw plugs.
8. Screw in and tighten screw plug oil drain (portal stage) (2).

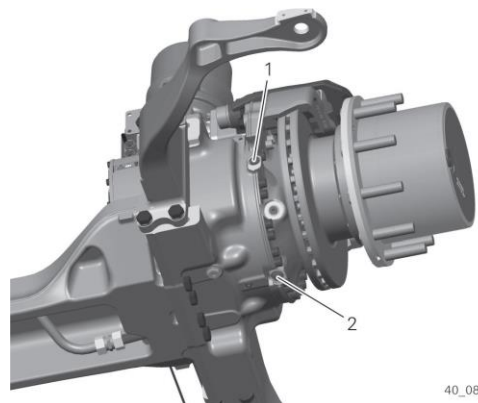

40_080058_01

Tightening torque: **50 Nm**

9. Fill in oil slowly at the oil filling hole, until the oil slightly exceeds the oil level hole (1).
 10. Check oil level after some minutes and correct if necessary.
 11. Screw in and tighten screw plug oil level and oil fill (portal stage) (1).
- Tightening torque: **50 Nm**

Changing oil (planetary drive)

Requirements:

- The axle is installed into the vehicle horizontally.
- Vehicle is in horizontal position in all directions.

Risk of burns due to contact with hot oil.

Slight or moderate injury possible.

- Wear protective goggles.
- Wear protective gloves.

1. Thoroughly clean the screw plug oil drain/oil level/oil fill (planetary drive) (1).
 2. Rotate the planetary drive so that the screw plug oil drain/oil level/oil fill (planetary drive) (1) is on top ("12 o'clock position").
 3. Place a suitable container under the screw plug oil drain/oil level/oil fill (planetary drive) (1).
 4. Slowly loosen and remove the screw plug oil drain/oil level/oil fill (planetary drive) (1).
 5. Rotate the planetary drive so that the screw plug oil drain/oil level/oil fill (planetary drive) (1) is on the bottom.
 6. Completely drain oil into the containers.
 7. Let axle cool down to ambient temperature.
 8. Rotate planetary drive until the reference line is in a horizontal line.
 9. The use of a non-approved lubricant can lead to property damage.
- Fill in oil slowly at the oil filling hole, until the oil slightly exceeds the oil level hole (1).
10. Check oil level after some minutes and correct if necessary.
 11. Renew O-ring of the screw plug oil drain/oil level/oil fill (planetary drive) (1).
 12. Screw in and tighten screw plug oil drain /oil level/oil fill (planetary drive) (2).
- Tightening torque: **150 Nm**

Changing grease

The grease in the hub can only be changed, if the hub is removed and completely dismantled.

Change the grease:

- If grease is leaking on the shaft seal of the brake disk side (a slight grease collar of approx. 1 mm is permitted).
- If the brake has overheated. This is e.g. recognizable on burnt pressure piece bellows.
- After the regular interval.

CHECKING BRAKE DISCS AND PADS



The pad wear indicator should be checked regularly. When the pad indicator reaches 10%, Isuzu service should be contacted for replacement.

Right and left brake pads on the same axle must be replaced together. The original brake part defined by the vehicle manufacturer must be used. Brake discs should also be checked during pad replacement and replaced if necessary. Otherwise, braking performance may be adversely affected.

STEERING HYDRAULIC TANK

The steering oil tank is located behind the left front wheel, accessible through the maintenance hatch behind the left front wheel.

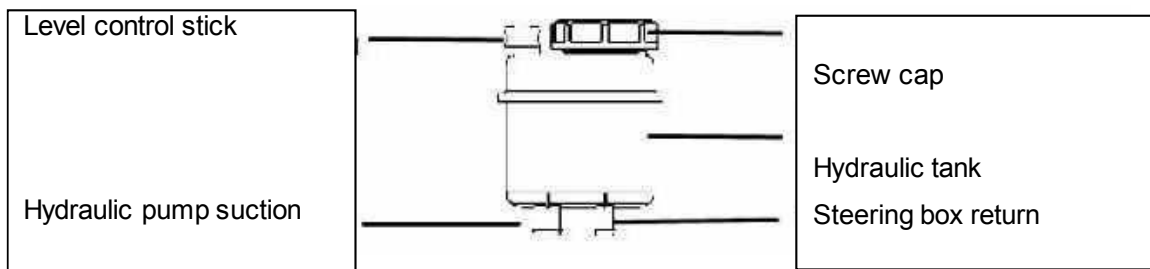
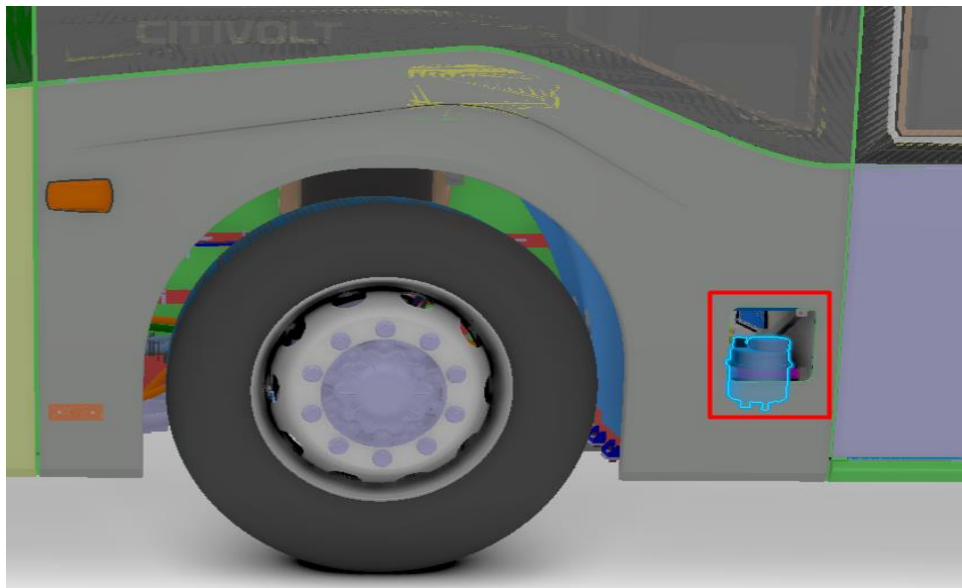

There is a screw cap and oil level dipstick on the tank. The oil level should be checked every 3000 km. To check the oil level, the rod is removed, there are minimum and maximum lines on the rod, the oil level should be between these two lines. For trouble-free operation of the power steering and pump, the oil specified by the vehicle manufacturer must be used.

If there is not enough oil in the steering system, the vehicle should not be started; otherwise the steering wheel may be damaged. If the amount of oil is low, oil must be filled up to the maximum line on the rod.

SMART AIR DRYER



Air dryer + Four-way valve (IAPU) is located in the area behind the left front wheel of the vehicle. The task of the IAPU is to take the moisture and oil in the air pressed from the compressor, adjust the system pressure of the vehicle and send the air to the vehicle air tanks under appropriate conditions.

At the top of the IAPU is a cartridge with a maintenance interval. At the bottom, there is a silencer that reduces the sound while expelling the air.

When the air of the vehicle reaches the desired limit, it throws out the water and oil accumulated in the cartridge with some air. It stops the compressor from running by informing the compressor.

The smart air dryer activates the air compressor when the air system pressure drops to 8.3bar and turns off the air compressor when the air system pressure reaches 9.8bar

EMPTYING THE WATER ACCUMULATED IN AIR TANKS

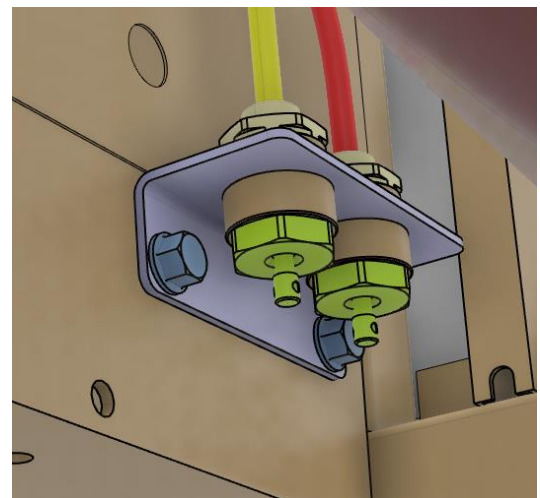
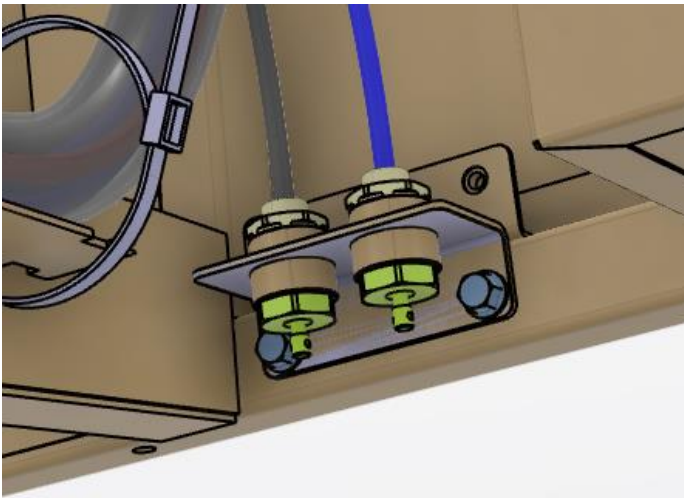

There are 2 water drains (front brake tank and hand brake release tank) in the front part of the left front wheel.

There are 2 water drains (rear brake tank and accessory tank) in the front part of the right rear taker.

The water that accumulates by condensing in the air tanks should be discharged daily by pressing the pin located under the drain.

ELECTRIC AIR COMPRESSOR

As seen in the pictures below, the air compressor is located in the rear engine room of the vehicle between the radiator and the engine.

When the right side cover of the engine room is opened, the air compressor air filter is reached in the upper part of the radiator. The cartridge is replaced here.

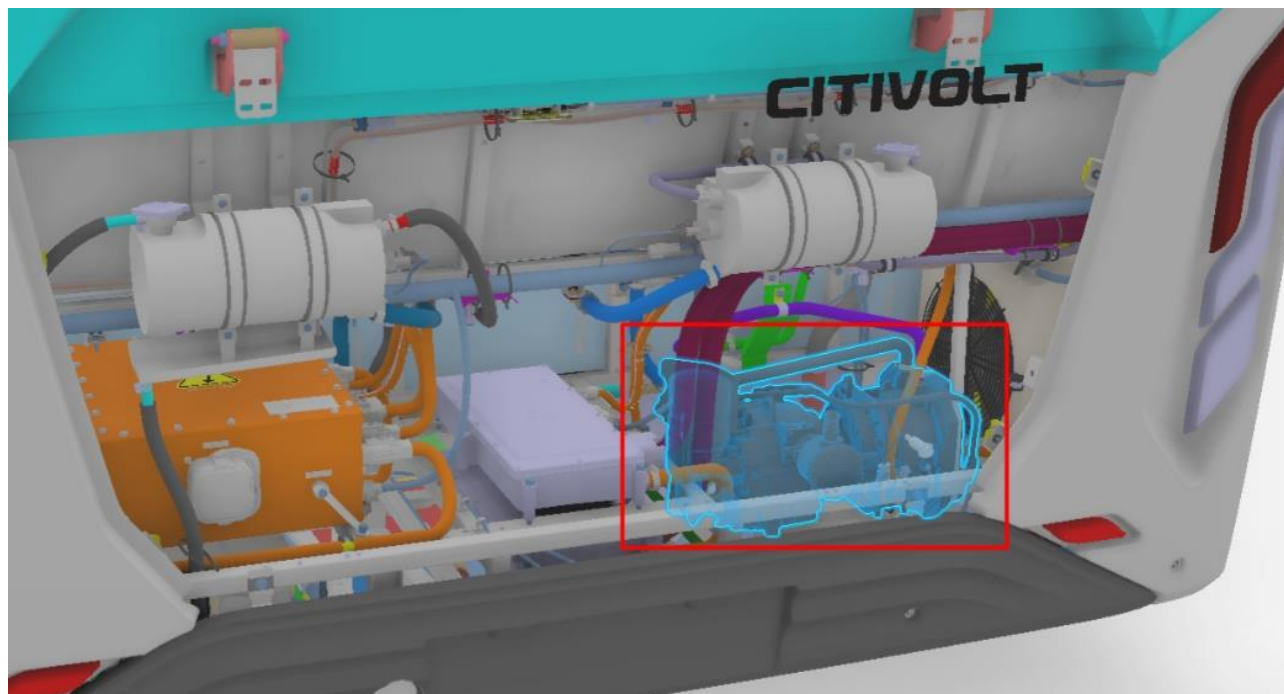

Location of air compressor air filter

GLASS FOUNTAIN WATER TANK

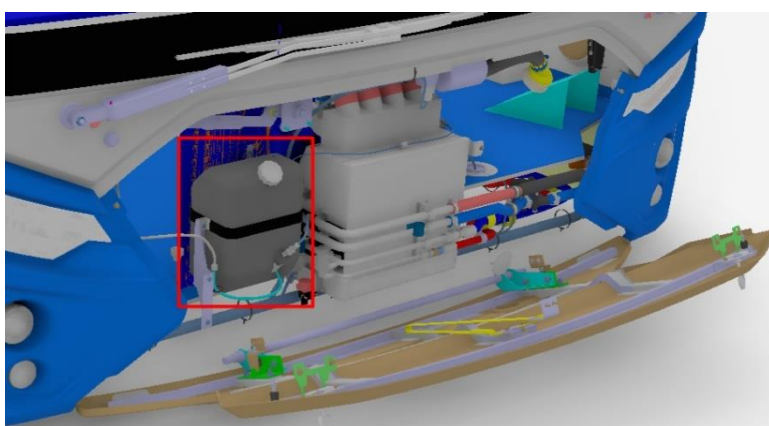

The glass fountain water tank can be accessed by opening the front bumper body cover. After opening the lid, a maximum of 10 liters of washer fluid can be filled.



Antifreeze should be used to prevent the glass from freezing in cold weather.

REPLACING WINDSHIELD WIPERS

There are two outer wiper arms, right and left.

To replace the wiper blade, remove the bolt and ring nut in the middle of the blade (Fig. 1 and Fig. 2).

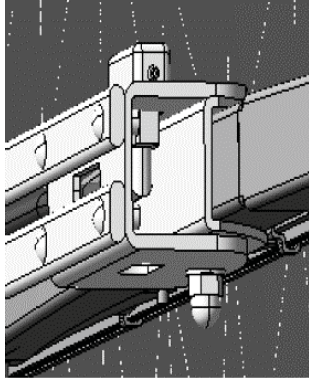

Fig. 1

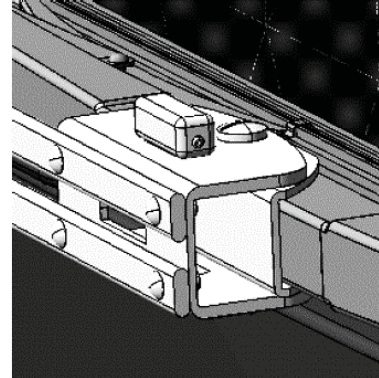

Fig. 2

In order to replace the entire outer wiper arm, the plastic cover at the point where the arm is connected to the vehicle body is opened, the ring nut here is removed and the wiper arm is removed (Fig. 3)

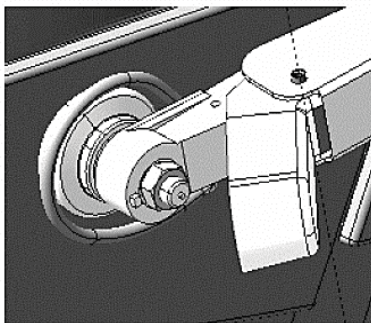

Fig. 3

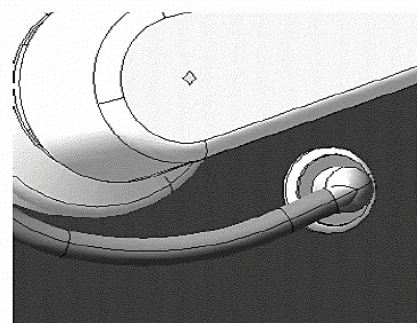

Fig. 4



Wiper blades should be checked in winter and replaced if necessary. Changes in the internal mechanism of the wipers should be made by authorized services

FUSE/RELAYS



Fuse and relays are located in two different places in the vehicle. The fuses used in the vehicle are blade type. In the event of a short circuit or malfunction in the system, the relevant fuse blows to protect the electrical components. After the electrical fault is cleared, it is replaced with a fuse of the same amperage Value.

- 1- It is located in the cabin at the bottom right of the front door entrance of the vehicle. The fuse label is on the console cover.
- 2- It is located inside the left rear cover of the vehicle. The fuse label is visible when the cover is opened.

PRECAUTIONS FOR BATTERY USAGE

Keep the battery clean. If the battery is left dirty, contaminants can mix with the battery fluid, damage the battery plates, short-circuit the top of the battery and reduce the battery's service life.

When Performing Inspection or Maintenance Operations

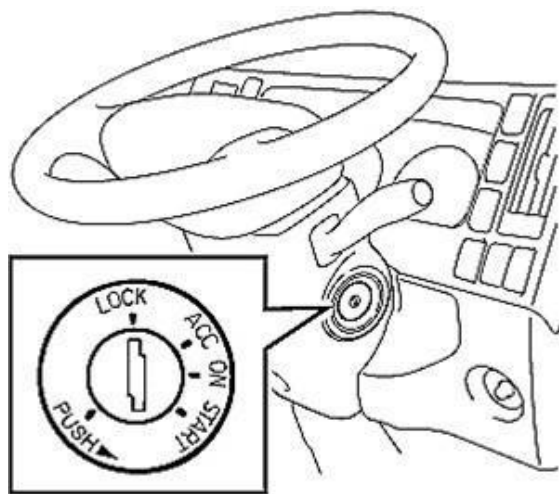

Before checking and maintaining the battery and other parts of the electrical system, turn the ignition switch to the "LOCK" position, turn all other Buttons to the "OFF" position and disconnect the battery negative cables.

There is a danger of damage to electrical parts if inspection or maintenance is performed while the battery remains connected.

Battery Removal

When removing the battery, first disconnect the battery cable from the negative pole. If the battery cable remains connected to the negative terminal, if the tools come into contact with the positive terminal, a short circuit may occur in the vehicle and cause dangerous electric shocks. Also, the electrical system may be damaged



If the battery switch is to be turned off, wait at least 70 seconds after the ignition is turned off.

Charging the Battery

- Before replacing the battery, remove the battery from the vehicle, place it in a well-ventilated area and remove the battery covers. If the battery is to be charged while inside the vehicle, be sure to disconnect the battery cables first.
- Make sure it is turned off when the charger is connected to or disconnected from the battery.
- In case of fast charging, the battery cables must be disconnected. Failure to follow this precaution could result in the alternator running out of fuel.

Installing the Battery

1. When installing the battery in your vehicle, make sure it is correctly oriented and securely installed without any looseness. If the battery is not installed correctly, the battery box and battery plates may be damaged as a result of jolts while driving.
2. When connecting the battery cables, start with the positive pole and then connect the negative pole.

Using the Battery as a Direct Power Source

The battery should not be used directly as a 12 volt power source.

If your battery needs to be used as a direct power source, consult your Isuzu authorized service.

Checking the Battery Water Level Daily Check

Daily check

Open the battery cover and check if the liquid in the battery chamber is within the specified range.

The battery fluid surface should be between "UPPER LEVEL" and "LOWER LEVEL." If the

fluid surface cannot be seen clearly, gently shake the vehicle.

If there is no level mark on the case, a 10-15 mm gap from the top to the battery plates is considered appropriate

Filling the Battery Water

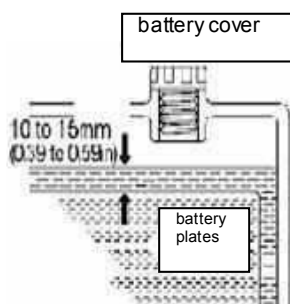

If the amount of battery fluid in the battery is not sufficient, remove the caps, add distilled water until the surface is close to the "UPPER LEVEL" mark or 10-15 mm from the top to the battery plates. After you have finished checking the oil level, securely attach the cap and cap.



- Battery water should never be filled above the "UPPER LEVEL" line. Failure to observe this precaution may result in battery water spilling and corrosion of battery terminals and other parts. Spilled battery water should be cleaned immediately with water.
- After adding battery water, the battery must be recharged (by driving). If you do not recharge the battery during the winter months, the battery water may freeze and the battery box may be damaged.
- If the battery water level continues to drop rapidly, which may rarely occur, have a service performed at the nearest Isuzu authorized service immediately.

JACK USE AND TIRE CHANGE

The jacking points on the vehicle are in front of the front wheels and behind the rear wheels.

When using the jack;

- Make sure the drain screw is tight.
- Use your own jack handle to raise the jack
- Turn the drain screw counterclockwise two turns to lower the jack.

Tire change;

- Place a wedge on the tire diagonally opposite the tire you are lifting.
- Loosen the wheel nuts of the tire to be replaced, but do not remove them.
- Jack up the vehicle using the jack point on the back of the tire to be replaced until the tire is completely off the ground.
- Remove the wheel nuts and tire.
- Install the spare tire
- Make sure the tire is seated
- Tighten the diagonal opposing wheel nuts with a torque of 500 ± 50 Nm in three stages.

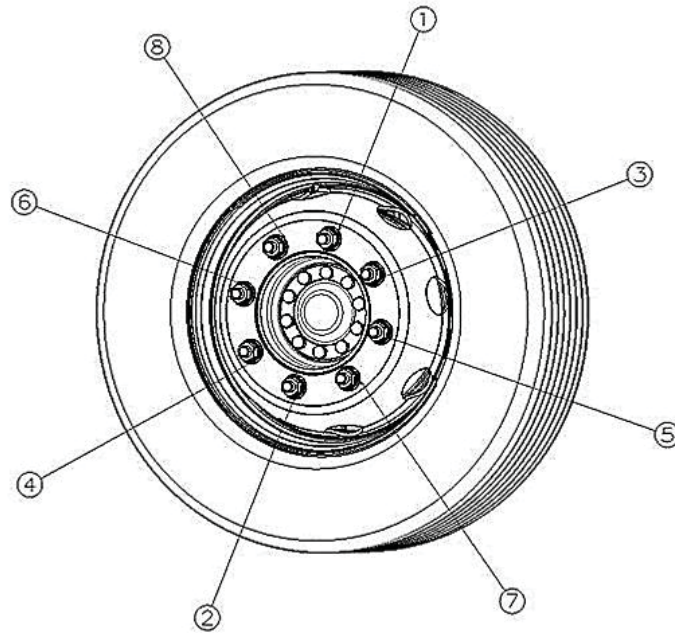

- Slightly loosen the evacuation screw on the jack to lower the vehicle.



- Make sure the jack is placed on flat and solid ground.
- Do not start the engine while the vehicle is on the jack.
- Do not get into the vehicle while the jack is being used.
- Unload the passengers before starting the tire change.
- Make sure the gear is in the park position, set the parking brake and turn on the hazard warning flashers.
- If there is a high voltage line around during tire change, tire change should not be made.
- Equipment to be used must be insulated.
- When the vehicle is jacked up, it is necessary to enter between the wheel and the fender or under the vehicle. Getting under the vehicle and between the fenders can result in death.

NOTE: If the tire pressure is constantly decreasing, there may be an object stuck in the tire. Check whether there is an air leak in the tire or the valve.

EASY SERVICEABILITY

Easy access to the necessary components is provided by opening the rear cover and side covers for the modifications to be made on the vehicle in case of vehicle maintenance or breakdowns.

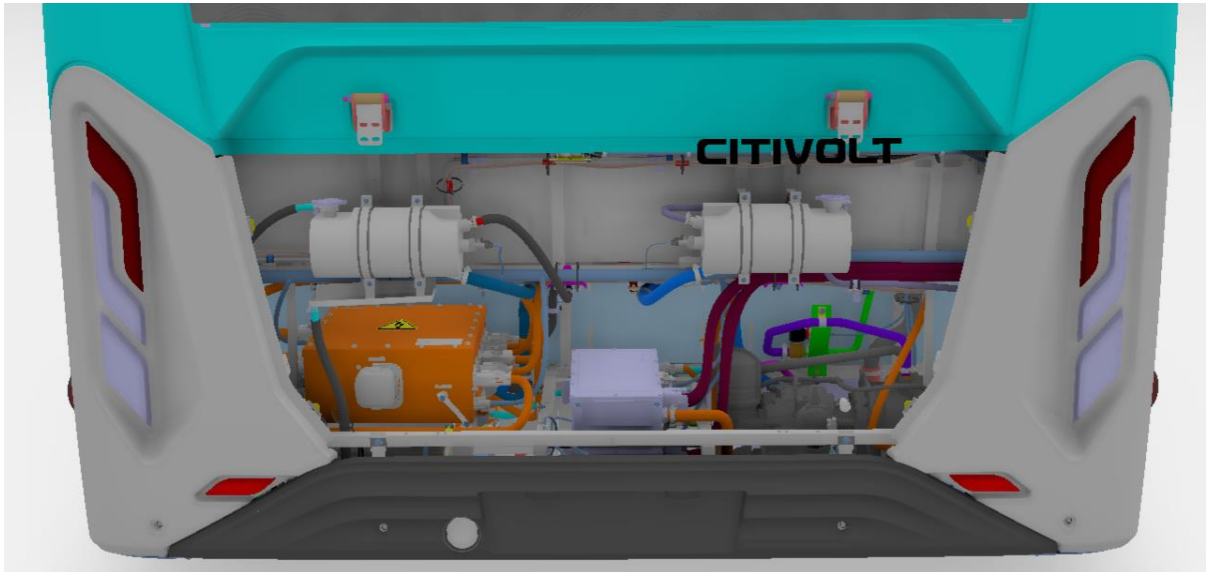

CORROSION & PREVENTIVE METHODS

What is Corrosion?

Corrosion is a state of deterioration in metals (steel, copper, zinc, aluminum and their compounds) caused by oxidation or chemical action..

Observation

- Red rust on steel parts,
- White spotting on zinc parts,
- White spotting on Dacromet /

Geomet coated parts,

- Green rust on copper parts,
- White spotting on aluminum parts.

Corrosion Causes

1- User Errors

Failure to comply with the rules specified in the user, workshop warranty and service manuals may cause corrosion.

2- Environmental Factors

Environmental and geographical factors determine corrosion factors.

Corrosion Zones

Anti-corrosion methods can be applied to three main areas on the vehicle;

- Not responding to the scratches on the painted parts of the vehicle in a timely manner,
- Failure to comply with preventive maintenance procedures,
- Failure to comply with preventive activities before the winter season
- Hot and humid areas (eg seaside)
- Cold and snowy areas (road defrosting)
- Cold and rainy regions,
- Industrial zones
- Additional applications (solid or liquid salt) to open public roads)

A SECTION A (Engine Compartment)

B SECTION B Chassis (including trunk component)

C SECTION C Side Panels and other vehicle



Corrosion Maintenance Procedure

Every vehicle should be checked every 6 months. If the vehicle is not checked, it will be out of warranty. If the vehicle is damaged, it must be repaired so that there is no rusting problem.

 **CAUTION**

Internal profiles should be checked every year, if wax is removed, wax1 treatment is applied to the required structure of the body with service approval.

 **CAUTION**

On the underbody coating, peeling and shedding should be checked 3 times during the winter season. Before the start of the winter season, the end of January (when the high winter season is the end of October), the end of the winter season If there is wear, the coating² should be renewed in the necessary areas

 **CAUTION**

It is recommended to wash the vehicle with low-pressure water at least once a week and the underbody at least once a month in order to prevent the contamination from damaging the chemicals. High pressure water causes wear on the underbody lining. If any signs of corrosion are confirmed, restart without delay.

VEHICLE RECOVERY INFORMATION

ANADOLU ISUZU



From 2023,

CITIVOLT 12

TECHNICAL DETAILS

A

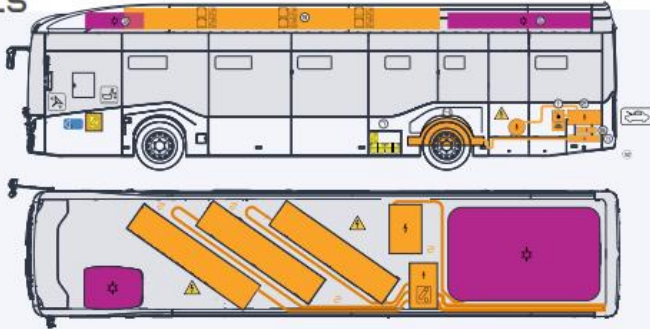

1 Charge Plug	5 Passenger Air Conditioner	8 HV Cable	11 E-axle Motor Inverter
2 Power Distribution Unit	6 DC-DC Converter	9 HV Batteries	12 E-Compressor
3 Driver Air Conditioner	7 2x12V Batteries	10 HV Disconnect Switch	13 Air Conditioner Inverter
4 E-axle Motor			

B



Battery High Voltage	Vehicle Induction Charging	Warning, Electricity	High Voltage Power Cable
Shutdown Power	High Voltage Component	Steering Wheel Adjustment	Air-Conditioner
Disconnect High	Bonnet; Hood	Seat Adjustment	Left Hand Drive
Battery Low Voltage			

•CTIF (International Technical Committee for the Prevention and Suppression of Fire) and Euro NCAP (European New Car Assessment Programme) have concluded a collaboration to develop ISO standard 17840 "Rescue Information", which has been the international standard for the entire transport sector since 2019.

•The ISO 17840 standard defines a rescue document that provides necessary and useful information about the vehicle in order to support the rescue team in rescuing the vehicle occupants as quickly and safely as possible in the event of a possible accident.

•It is aimed to issue a recovery document for each vehicle, especially electric vehicles.

• QR codes have been added to various points on the vehicle to speed up the rescue team's access to information.

• The fastest and safest intervention is aimed with the QR code, which is engraved on the points of the vehicle that are least likely to be damaged.

• Currently, recovery documents have been prepared for the electric vehicle CITIVOLT, and the documents have been converted into QR codes and placed on the vehicle.



RESCUE CARD



PERIODIC MAINTENANCE

BEFORE DRIVING

Proper maintenance and driving is important not only in extending the service life of your vehicle, but also in the battery and electric motor.

Check Daily

For safe and comfortable driving, record the distances traveled and the condition of the vehicle while driving. Perform inspections at appropriate intervals and perform maintenance according to inspection findings. If an inspection reveals an abnormality or if the vehicle has had an abnormality from previous driving, take the vehicle to the nearest Isuzu Dealer before being driven again.

Günlük Kontroller Kontrol Listesi:

1. Checking components that showed abnormalities during previous driving
2. Electric motor coolant level
3. Power steering fluid level
4. Fan hydraulic fluid level
5. Brake system air pressure level
6. Brake pedal release
7. Exhaust noise from brake valve
8. Increase/decrease of air pressure level
9. Operation of meters, indicators and warning/indicator lights
10. Parking brake
11. Windshield washer fluid spray status and windshield wiper activity
12. Windshield washer fluid level
13. Steering wheel clearance and mounting condition
14. Operation of horn and turn signal lamps
15. Battery charge level
16. Lighting, flashing or damaged lights
17. Battery fluid level
18. Drain the condensed water (especially in winter) in the air tanks.
19. Electric engine coolant, brake fluid, power steering fluid, fan hydraulic fluid leak
20. Air pressure
21. Cracks and other damage
22. Abnormal wear
23. Tread depth of tires
24. Disc wheel assembly status
25. Brake efficiency
26. Checking the engine at low speeds and accelerations
27. Wear and corrosion control of chassis and body parts
28. Check the bus crash and original part condition.

Weekly Maintenance

- Check the tire pressures with the weather clock.
- Check the steering fluid tank level.
- Check the air suspension bellows (holes, damage, etc.) while the engine is running.
- Check the air cleaner limit.
- Check the washer fluid level.
- Wear and corrosion control on chassis and body parts

CAUTION!

- Water jet cleaning machine should not be used inside the bus.
- Abrasive materials should not be used on the bus surface.
- The car should not be washed with a car wash brush.
- Informing the authorized service in case of accident
- Regular maintenance at authorized service

Periodic Maintenance Chart

The main periodical maintenance interval is 240000 km. Maintenance after 240000 km is the same as maintenance intervals after 30000 km.

I: Inspect then clean, repair or replace as necessary

R: Replace

A: Adjust

L: Lubricate

NOTE: Change the **filter/fluids** before the recommended distance or month, whichever is earlier.

I

Electrical System Components

Maintenance Interval (x1000 km)	30	60	90	120	150	180	210	240
PDU electrical connections				I				I
DC/DC Converter electrical connections				I				I
High voltage system electrical connections				I				I
On-board charger electrical connections				I				I
Air conditioner inverter				I				I
Intelligent air dryer filter replacement	R: every 12 months							
Electric power steering pump	I: every 12 months							
Electric steering pump bearing replacement	R: every 200,000 km							
External cleaning of the electric radiator		I		I		I		I
Electric fan function check	I	I	I	I	I	I	I	I
Checking the socket connections on the battery	I	I	I	I	I	I	I	I
Checking the connections of the battery to the chassis	I	I	I	I	I	I	I	I

Electric Rear Axle

Maintenance Interval (x1000 km)	30	60	90	120	150	180	210	240
Compact bearings in the wheel heads on the front and rear axles (hub unit)	R: 500.000 km or 4 year							
Rear axle oil change		R		R		R		R
Rear axle greasing	L: 500.000 km or 4 year							
Checking the axle sensor cable and connectors	I	I	I	I	I	I	I	I
Checking the VMU interface connector	I	I	I	I	I	I	I	I
Coolant in/out MCU leak check	I	I	I	I	I	I	I	I
Coolant in/out engine leak check	I	I	I	I	I	I	I	I
Axle general control	I	I	I	I	I	I	I	I
MCU component control	I	I	I	I	I	I	I	I
Coolant level control	I	I	I	I	I	I	I	I
Coolant change	R: every 36 month							

Electric Air Compressor

Maintenance Interval (x1000 km)	30	60	90	120	150	180	210	240
Oil level control	I: Once a week							
Oil change	R: Every 12 months or 60.000 km							
Oil filter change	R: Every 12 months or 60.000 km							
Air filter change	R: Every 12 months or 60.000 km							
Annual service check		I		I		I		I

Axles

Maintenance Interval (x1000 km)	30	60	90	120	150	180	210	240
Front axle king pin bearing grease	L	L	L	L	L	L	L	L
front axle covers	I	I	I	I	I	I	I	I
front axle bushings	I	I	I	I	I	I	I	I
Differential oil	I	R	I	R	I	R	I	R
Differential leak filter	I	I	I	I	I	I	I	I

Hydraulic wheel

Maintenance Interval (x1000 km)	30	60	90	120	150	180	210	240
Power steering oil	R: every 240,000 km or 24 months							
Power steering tank oil level check	I: every 3000 km							
Oil leak in the power steering system	I	I	I	I	I	I	I	I
hydraulic steering linkage	I	I	I	I	I	I	I	I
power steering hose	I	I	I	I	I	I	I	I

Heating Systems

Maintenance Interval (x1000 km)	30	60	90	120	150	180	210	240
Front heater external suction filter change	R: every 12 months							
Front heater flap motors should be cleaned with air and lubricated with Würth HHS 2000 liquid grease.	R: every 12 months							
The pre-heater condensation pool housing should be checked for clogging.								
Under the driver, between the heater grill and the radiator should be cleaned with air.	I: every 12 months							
The front passenger heater grille and radiator should be cleaned with air.	I: every 12 months							
The rear passenger heater grille and radiator should be cleaned with air.	I: every 12 months							
power steering hose								

General Vehicle Care

Maintenance Interval (x1000 km)	30	60	90	120	150	180	210	240
Front suspension links								
Rear suspension links								
wheel nuts								
Tire pressures								
Hub bearing								
Leakage in brake pipe and brake hose								
Checking the brake pad and disc								
Looseness in shock absorbers and fasteners								
level valves								
air bellows								
ESC system control								
Rear and front brake system control								
Brake, turn signal, parking and fog lamps								
interior lighting								
Windshield wiper and washer system								
Fuse panel wiring and socket connections								
Battery connection cables								
Battery electrolyte density								
Air door adjustment								
Safety gear function of all doors								
Air leakage, damage, tightness and door function in door elements								
Rearview mirrors parts								
gas and brake pedal								
Wear and corrosion control of chassis and body parts	I: once a week							
Underbody inspection and repair	I: once a week							
Bus accident and original part condition check	I: daily							
A/C compressor oil	I : every 24 months & R : when decreasing							
A/C gas and oil	I : every 24 months & R : when decreasing							

NOTE

- Cartridge (filter on the smart air dryer) needs to be changed at 1-year intervals or when the iAPU gives a warning (before the 1-year period expires).
- For the fire extinguishing system; extinguishing fluid should be changed every 5 years, tanks should be changed every 10 years.
- In severe conditions (frequent short driving distances, dusty or bumpy roads, towing a trailer or mountain climbing), maintenance intervals should be halved.
- The air intake filters of the air conditioner should be removed and cleaned on a weekly basis. The time may be extended depending on the pollution situation.
- Since the air conditioner air intake filters can be reused, they are not easily deformed. It should be changed when it is excessively deformed and there is visible deformation in the filter.
- Suspension bushings (stabilizer and other) should be replaced if 30,000 km of wear control is required.
- Water should not be kept in any heater.

Passenger Air Conditioner

Maintenance Interval (x1000 km)	30	60	90	120	150	180	210	240
A-Check all unit attachments and all refrigerant pipe connections for tight fit and security / 4 weeks after commissioning	I: every 12 months							
A-Visual inspection of all components for corrosion, wear and mechanical damage	I: every 6 months							
A-Check screw connections for security	I: every 6 months							
A-Check pressures and temperatures	I: every 12 months							
A-Examination for tightness with leakage finder	I: every 12 months							
A-Inspect condenser/ evaporator fins for pollution, clean as necessary - depending on the mileage of the vehicle and the operating conditions	I: every 12 months							
A-Check fresh air/ circulating air filter for pollution (if installed) - depending on the mileage of the vehicle and the operating conditions	I: every 12 months							
A-Inspect refrigerant collector for cracks and corrosion (pure AC units) - if damaged replace refrigerant collector	I: every 6 months							
A-Replace filter dryer	R: every 12 months							
A-Check high / low pressure switches via SC620	I: every 12 months							
A-Oil level in the compressor: When replacing the filter dryer, 50ml oil must be refilled.	L: every 12 months							
A-Check condenser fans for function	I: every 6 months							
A-Check evaporator fans for function	I: every 6 months							
B-Check all plug connections for tight fit	I: every 12 months							
B-Visually inspect all electrical cables for chafing	I: every 12 months							
A-Functional test of the air-conditioning unit in the test mode	I: every 12 months							
A-Check function of the reversing valve when switching from cooling to heating mode	I: every 12 months							
B-Examine the cooling fins of the frequency converter for contamination and clean as required	I: every 12 months							
A-Test the insulation resistance of the unit	I: every 6 months							
B-Check torque of all cable glands	I: every 6 months							

NOTE

Marked with "A" category maintenance and service work requires a certificate of the following two qualifications:

- electrotechnical instructed persons (EuP)

EuP: instructed in non-electrical work at / near of high voltage equipment, knows dangers, not his own responsibility (supervision and control) training according to DGUV 200-005

- in cooling technology trained personnel with certificate of competence acc. to regulation (EC) No. 307/2008

In addition, the country-specific regulations with regard to qualified specialist personnel must be observed.

Marked with "B" category maintenance and service work requires a certificate of the following qualifications:

- Qualified electrician for high voltage systems in motor vehicles Crafts profession activity with repetitive character, training according to DGUV 200-005

- in cooling technology trained personnel with certificate of competence acc. to regulation (EC) No. 307/2008

In addition, the country-specific regulations with regard to qualified specialist personnel must be observed.

Driver Air Conditioner

Maintenance Interval (x1000 km)	30	60	90	120	150	180	210	240
Connections test for leaks with leak tester	I: every 12 months							
Condenser check condition of fins (must be cleaned if soiled)	I: every 6 months							
Condensation water drain check openings and clean if necessary	I: every 6 months							
Rooftop air-conditioning unit check overall condition and secure attachment of connections	I: every 12 months							
Compressor check for abnormal noises during operation	I: every 6 months							
Supports check condition and function	I: every 12 months							
Elec. connections check for signs of oxydation	I: every 12 months							
Power supply wires check for unobjectionable condition	I: every 6 months							
Connectors check for unobjectionable condition and secure attachment	I: every 6 months							

NOTE

Under no circumstances may refrigerant be discharged into the atmosphere.

WARNING

Do not perform soldering or welding directly on components of the closed refrigerant circuit or in its vicinity. The heating will cause a rise in the circuit pressure. There is a danger of explosion. Before performing any work allow the system to cool down completely. Risk of injury due to burns on the condenser, compressor and refrigerant hoses.

Installation, maintenance and repair work must be carried out by duly qualified personnel. Such work may only be undertaken with the engine off and the power supply switched off. The battery must be disconnected before starting the work. Do not wear metal jewellery (bracelets, watches, necklaces, rings) when working on the air conditioning system.

VEHICLE MODEL : VIN : PLATE NUMBER :		Long-Term Storage Inspection and Maintenance Checklist for Electric Buses													
No	List of Control	Description of Control	Week 1 Date:...../...../	Week 2 Date:...../...../	Week 3 Date:...../...../	Week 4 Date:...../...../	Week 5 Date:...../...../	Week 6 Date:...../...../	Week 7 Date:...../...../	Week 8 Date:...../...../	Week 9 Date:...../...../	Week 10 Date:...../...../	Week 11 Date:...../...../	Week 12 Date:...../...../	
1	<i>Charging system control// Charge flap and switch control</i>	Check charging procedure steps. If you find out abnormal situation contact with technical support team.				■									■
2	<i>SOC Control</i>	Check State of Charge, SOC should be between 40% - 60% during storage period. If you notice excessive discharge, contact technical support.	■	■	■	■	■	■	■	■	■	■	■	■	■
3	<i>Apply *battery maintenance procedure</i>	Execute the prescribed battery maintenance protocol in accordance with manufacturer guidelines.				■									■
4	<i>Wax application for underbody</i>	Inspect the underbody for damage or rust. Reapply wax coating if necessary.													■
5	<i>Air Conditioning control (min.20 mins. operation)</i>	Operate the driver and passenger air conditioning systems for a minimum of 20 minutes. Evaluate cooling efficiency and verify blower functionality.				■									■
6	<i>Heating control (min. 20mins. Operation)</i>	Operate the driver and passenger heating systems for at least 20 minutes. Assess heating effectiveness and verify blower operation.				■									■
7	<i>Visual check</i>	Conduct a detailed visual inspection of the vehicle's exterior, including paintwork, windows, and windshield, for													■

		scratches, dents, or other damage.												
8	<i>Warnings on Cluster</i>	Examine the instrument cluster for any active warning lights or error messages. Document and resolve as required.	■	■	■	■	■	■	■	■	■	■	■	■
9	<i>Parking brake function control (Please turn on HV system while checking parking brake system)</i>	Test the activation and deactivation of the parking brake while ensuring the HV system is operational. Confirm proper functionality.	■	■	■	■	■	■	■	■	■	■	■	■
10	<i>Oil, coolant or other fluid leakage visual check</i>	Inspect all fluid systems, including coolant, oil, and hydraulic systems, for signs of leakage.		■		■		■		■		■		■
11	<i>Oil, coolant or other fluid level check</i>	Confirm that all critical fluid levels, including coolant, compressor oil, and steering hydraulic fluid, are within specified limits.								■				
12	<i>Auxiliary 24V Battery Control</i>	Check Auxiliary 24V battery voltage and physical conditions (damage, leakage etc.)	■	■	■	■	■	■	■	■	■	■	■	■
13	<i>Software and Firmware Updates</i>	Ensure that all vehicle software and firmware are up-to-date, and perform any required updates both prior to storage and during commissioning.								■				
14	<i>Tire Pressure and Condition Check</i>	Inflate tires to the recommended maximum pressure regarding user manual. Move the vehicle slightly forward and backward periodically to prevent flat-spotting.				■				■				■

General Storage Guidelines for All Battery Chemistries;

- **Temperature:** The storage environment should maintain a temperature between 15-20°C. Excessive temperatures can cause batteries to discharge faster, reducing their lifespan, while low temperatures may temporarily reduce their capacity. Keeping the temperature stable is key to ensuring longevity.
- **Charge State:** Batteries should be stored at a charge level of 40-60%. Storing batteries at full charge (100%) or fully discharged can cause capacity loss over time.
- **Humidity Control:** Vehicles should be stored in a dry, well-ventilated area with controlled temperature and humidity levels below 60%. Avoid exposure to direct sunlight or extreme weather conditions.
- **Packaging:** Batteries should be packaged in insulated boxes to prevent short-circuiting. Batteries should not be in direct physical contact with each other to avoid accidental damage or short circuits.

***Battery Maintenance Procedure;**

1. Adjust the SOC in the range of 20% - 30%
2. Turn the key to the "OFF" position, then turn the key to "ON" position, and turn off the on-board electrical equipment.
3. The key remains "ON" and let it stand for more than 3 hours, during which no additional operations are required.
4. A full charge is required after standing.
5. Battery maintenance is completed, discharge the bus until 40% - 60% SOC, and store the bus.

NOTE: Long idle times and long-term vehicle storage;

!!! Regularly check SOC state. Otherwise, the high-voltage battery can be damaged when there is excessive discharge.
48 hours and more than 48 hours of storage the main power switch must be turned off.

Even if you do not use the buses much, you should have periodic maintenance done before the bus starts normal operation.

6. TECHNICAL INFORMATION

Dimensions (mm)	
Maximum length	12030
Max width	2550
Maximum height	3400
Wheelbase	5850
Front length	2700
Back length	3480
Front track width	2152
Rear track width	1915
Interior height	Min 2150 / Max 2500
Weights (kg)	
Max loaded weight	19500
Front axle capacity	8000
Rear axle capacity	11500
Motor-Electric Vehicle	
Drive Type	Battery Electric Vehicle
Engine Type	Electric motor axle
Engine Model	ZF AVE 130
Maximum Net Power (kW)	2x125
Continuous Power (kW)	2 x 87 (30 min, ECE - R 85)
Continuous Torque (Nm)	-
Maximum Torque (Nm)	2x480 (motor output) / 2x11000 (on wheel)
Gearbox	
Differential Ratio	22,66
Steering System	Electrically Operated Hydraulic System
Max Speed	80 km/h
Climbing Ability (at Max Loaded Weight)	
	%26,7
Tires	
	275/70 R22,5
Suspensions	
Front	Air Suspension - 2 Air Bellows - Independent Suspension Electronically Controlled Air Suspension (ECAS)
Back	Air Suspension - 4 Air Bellows - Electronically Controlled Air Suspension (ECAS)
Bend iron	Front anti-roll bar (S)/Rear anti-roll bar (S)
Brake system	
Front / Rear	Disc / Disc
Short description	ABS, ASR (ESP/ESC), EBS Dual Circuit, Full Air Brake System with Electronic Actuator
Parking brake	Electrically Controlled Parking Brake
Auxiliary brake	Regenerative brake
Electrical System	
Rated voltage	24V
Accumulator	2x150 Ah
Electrical System-Electric Vehicle	
Operating voltage	660 V
Compliance with ECE-100 r2	Yes
Battery Type	NMC
Battery Capacity	225 kWh (O) [--> 247 kWh] 300 kWh (O) [--> 330 kWh] 375 kWh (O) [--> 412 kWh] 450 kWh (S) [--> 495 kWh]
Battery Position	Vehicle roof part
Range (km)	Std (450 kWh --> 495 kWh) up to 480 km (w/o AC) up to 310 km (w AC)
Guarantee	Battery condition should not drop below 80% within 6 years or 540000 km or 110000 kWh.
Air conditioning	
	(Passenger: 30 kW cooling capacity + 19 kW heating capacity [operation between -5°C/+15°C]) (Drive: 3.8 kW cooling capacity)

NOTE: Specified technical values are approximate and may vary depending on vehicle type and options.

PRESSURE VALUES		
Four Way Protective Valve	Static Shutdown Pressure	> 5.5 Bar
Air Dryer	Minimum Opening Pressure	8.3 Bar
Air Dryer	Maximum Closing Pressure	9.8 Bar
Tires	Cold Inflation Pressure	8.5 bar / 123 psi

OIL AND LIQUID PROPERTIES			
DEFINITION	CAPACITY	NORM	CLASS
*Rear axle	5.2 lt	ZF EcoFluid XE SAE 75W-85 28C	
*Rear axle		ZF EcoFluid X SAE 80W-90 12L	
Power steering fluid	7 lt	GM Dexron – III	AUTRAN DX III
Electric air compressor oil	1 lt	CHEVRON Cetus PAO 46 or CASTROL Alphasyn T46	-
Front suspension lubrication	0,3 lt	DIN51825: KP2K-20 ISO-L-XBCEB2	ZFTE-ML12G
A/C compressor oil	1600 ml	FV68H (PVE)	IDEMITSU KOSAN
**Glycol (50%) + Water (50%) (3 battery packs)	64,5 lt	-	BASF Glysantin G48
**Glycol (50%) + Water (50%) (4 battery packs)	70,9 lt	-	BASF Glysantin G48
**Glycol (50%) + Water (50%) (5 battery packs)	77,1 lt	-	BASF Glysantin G48
**Glycol (50%) + Water (50%) (6 battery packs)	83,3 lt	-	BASF Glysantin G48
Driver A/C gas	1,1 kg	R134A	-
Passenger A/C gas	4,8 kg	R407C	-

*Axles, which are delivered originally with Ecofluid X needs to be serviced with Ecofluid X and axles with Ecofluid XE needs to be serviced with the same oil. This is dependent on the sealing ring and required oil is marked at the type plate with lubrication list. If the sealing ring is changed to the new one (ESS-ring), then the Ecofluid XE must be used.

**Instead of BASF Glysantin G48, you can also use BASF Glysantin G40 and BASF Glysantin G30.

7. AUTHORIZED SERVICES

COUNTRY	STORE NAME	STORE ADDRESS	CONTACT NUMBER
ALGERIA	Spa Elsecom	Rue Baha H'med, BP 200 Bab Ezzouar - Alger	+213 (0)23 85 30 86
AZERBAIJAN	AZ Auto LLC	2207 Nobel avenue AZ1006 - Bakü	+(994) 124964598
BOSNIA	Sejari d.o.o. Sarajevo	Blažuj 78, 71215 Blažuj - Sarajevo	+387 33 770 306
BULGARIA	Isubus Ltd.	Botevgradsko Shose Blvd. 1839 Sofia	+(359) 28182929
CROATIA	Presečki grupa d.o.o.	Frana Galoviča 15 49 000Krapina	+385 (0)49 328 000
CZECH REPUBLIC	Turancar CZ. s.r.o.	Bavorská 856/14 155 00 Praha 5	+420 776 111 113
FRANCE	Fast Concept Car	Z.I La Ribotiere 85170 Le Poire Sur Vie	+33 25 13 41 034
GERMANY	Omnicar Fahrzeughandel GmbH	Weinbrennerstrasse 10 77815 BÜHL	+49 (0)7223 8061930
GREECE	Petros Petropoulos S.A.	96-104 Iera Odos 122 10 Athens	+(30) 210349 92 00
HUNGARY	Anadolu Rom Hungary	1135 Budapest Robert Karoly Ket. 96-98	+36 703730637
ISRAEL	Universal Trucks Israel Ltd.	Industrial Area Segula, P.O. Box 4599 Petach-Tikva 49145	+972-3-9120010
ITALY	Midi Europe SRL	Via Crosaron, s.n. 37053 Cerea VR	+39 0442 328 212
LITHUANIA	UAB Saločiai Ir Partneriai	Mokyklos str. 1B, Bukiskės LT-14182 Vilniaus raj.	+370 5 2793000
MOROCCO	Maroc SDAMA	Route principale de Rabat 1, km 6,3 Ain Sebaa - Casablanca	+212 (0) 529 029 300
POLAND	Busimport PL Sp. z.o.o.	Gierłatowo 10A 62-330 Nekla Wielkopolskie	+48 61 43 86 905
ROMANIA	Anadolu Automobil Rom. Srl	Soseaua Bucuresti-Ploiesti Nr. 110 Comuna CiolPani	+4021-266 8300
SERBIA	Auto Cacak Komerc Doo	Bore Stankovica 16 11 030 Belgrade, Makiš	+381 32 376 228
SLOVAKIA	Turancar	Bratislavská 29 94901 Nitra	+421 37 6555 777

MAY 2024